

Installation Instructions

I - Sheet Number BF25 Rev.A



AUTO VENT SHADE™

Bugflector® - Bugflector II® - Carflector®

For proper installation and best possible fit, please read all instructions **BEFORE** you begin.
For technical assistance or to obtain missing parts, please call Customer Relations at 1-800-241-7219.

Important Safety Information



- CAUTION - Before driving, ensure that the hood shield is properly secured to vehicle.
- Do not use automatic "brush-style" car washes.
- Do not use cleaning solvents of any kind.
- Periodically check all components for tightness.

Contents - 1 Piece Set

NOTE: Actual product may vary from illustration.



Hood Shield



Screws x4



Washer x4



Alcohol Pads x4



Bump On x4

Contents - 3 Piece Set



Hood Shield

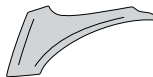

Drivers Side Fender Protector

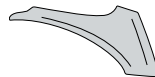

Passenger Side Fender Protector



Screws x4



Washer x4



Alcohol Pads x4



Bump On x4

Tools Required



Car Wash Supplies



Clean Towel

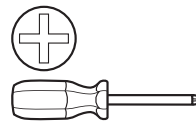

Phillips Screwdriver

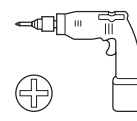

Power Screwdriver

Preparation Before Painting / Installation

- A trial fit is recommended to ensure proper positioning and fit.
- Check fit of parts before painting as we will not accept the return of modified or painted parts.
- Wash and dry your vehicle to remove any debris and/or dirt from the installation area.

Installation Steps

NOTE: Actual application may vary slightly from illustrations.

Open hood.

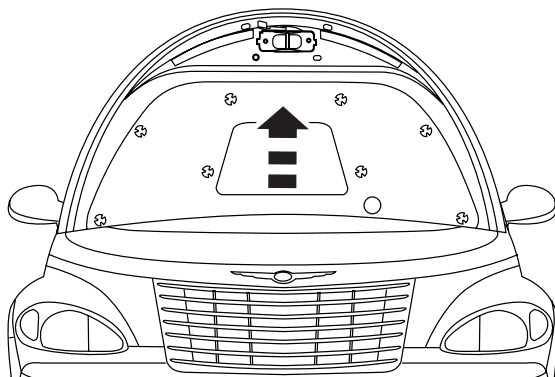

1

Clean the mounting location on the underside of hood with an alcohol pad.

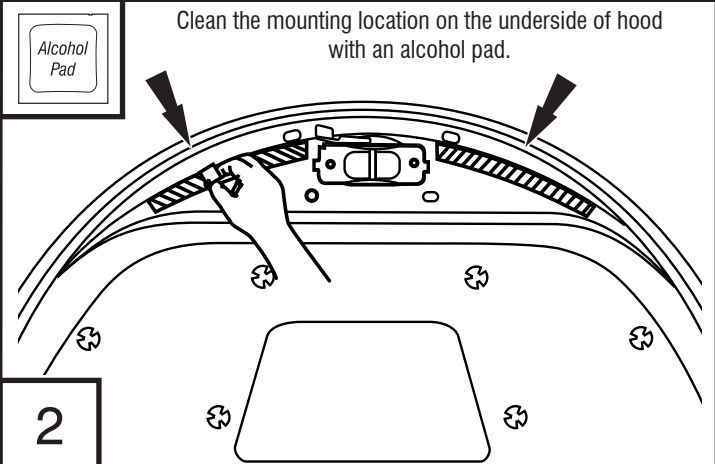

2

Installation Steps

NOTE: Actual application may vary slightly from drawings.

Expose 2" (5 cm) of tape liner from each end of the flanges on the hood shield.

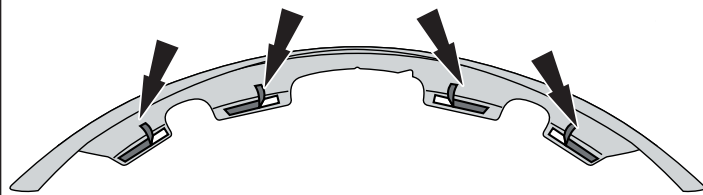

3

Align hood shield center point with center of hood. Press firmly to adhere previously exposed tape to hood and verify position.

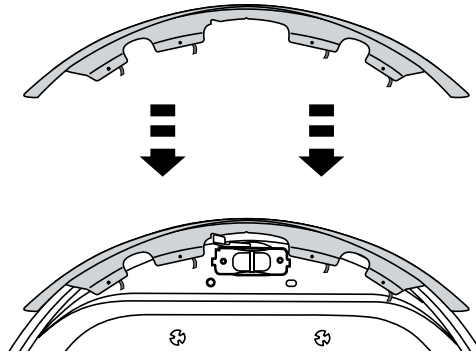

4

Remove remaining tape liner by pulling on free ends.

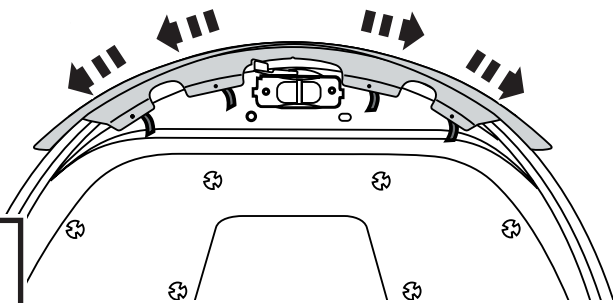

5

Press firmly along tape flanges to ensure proper adhesion.

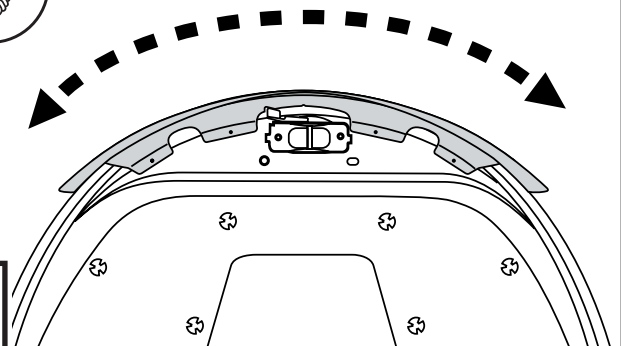

6

OPTIONAL: Install (4) self tapping screws through the holes on hood shield. A power screwdriver is recommended but once the screw penetrates the inside metal panel use a regular phillips screwdriver the remainder of the way.

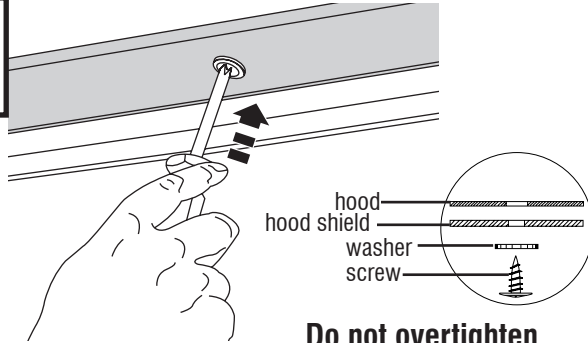
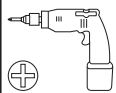

Do not overtighten

7

Close hood.

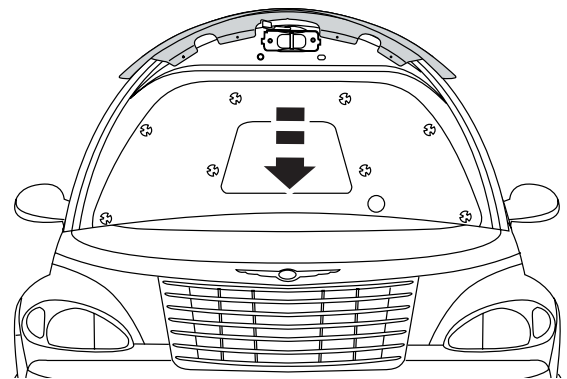

8

Fender Protector Installation

Clean mounting location above headlights and beside grill.

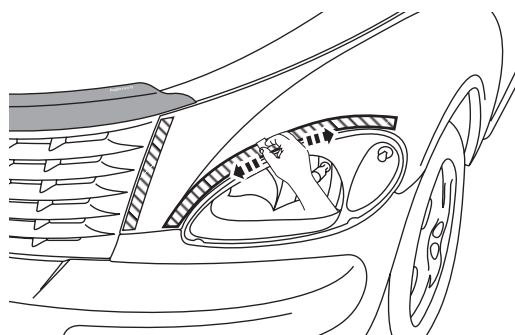

9

Expose 2" (5 cm) of tape liner from each end of the flanges on the fender protector.

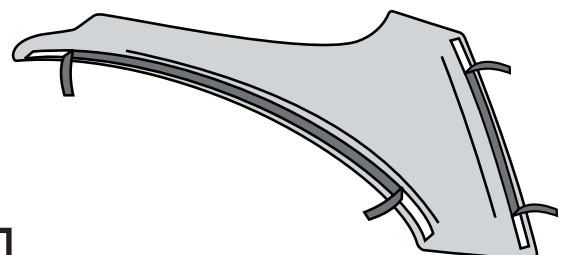

10

Installation Steps

NOTE: Actual application may vary slightly from drawings.

Align fender protector with fender. Press firmly to adhere previously exposed tape to fender and verify position.

11

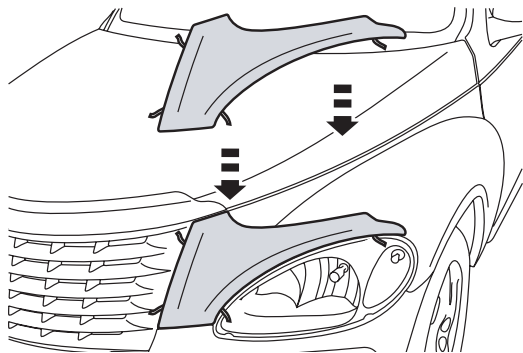

Remove remaining tape liner by pulling on free ends.

12

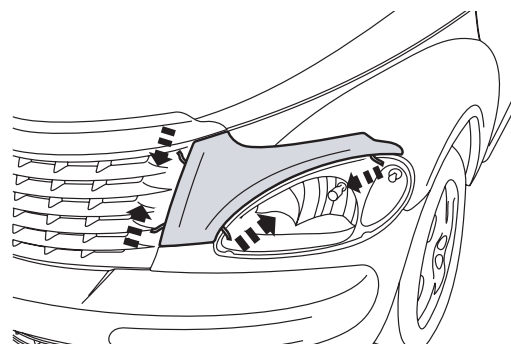

Press firmly along tape flanges to ensure proper adhesion.



13

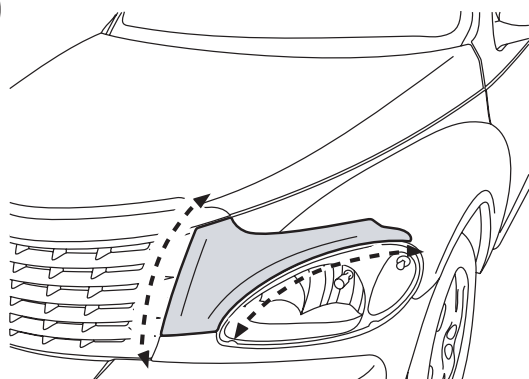

Apply bump ons as indicated. Repeat steps 9-14 for passenger side.



14

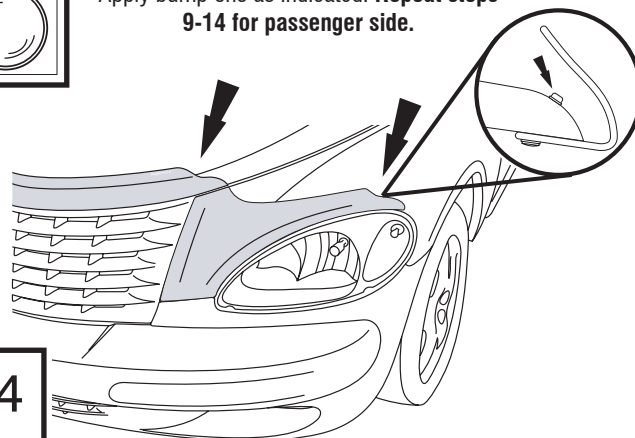

Care and Cleaning

- Wash only with mild soap & dry with a clean cloth.

Congratulations!

You have purchased one of the many quality Auto Ventshade™ branded products offered by Lund International, Inc. We take the utmost pride in our products and want you to enjoy years of satisfaction from your investment. We have made every effort to ensure that your product is top quality in terms of fit, durability, finish and ease of installation.



AUTO VENTSHADE™

Lund International, Ventshade Accessories Division

655 Raco Drive, Lawrenceville, GA 30045

800-241-7219 • Fax 770-339-5839 • Visit us at lundinternational.com



© 2005 Lund International, Inc. All rights reserved.

Auto Ventshade™, the Auto Ventshade™ logo and the AVS™ logo are trademarks of Lund International, Inc.





Bugflector® - Bugflector II® - Carflector®

Pour obtenir une installation correcte et le meilleur ajustement possible, lire toutes les instructions AVANT de commencer. Pour toute assistance technique ou obtention de pièces manquantes, appeler le service des relations avec la clientèle au 1-800-241-7219.

Informations importantes concernant la sécurité



- ATTENTION – Avant de conduire, s'assurer que le pare-insectes est solidement assujettie sur le véhicule.
- Ne pas utiliser les stations de lavage de voitures à brosse.
- Ne pas utiliser de solvants.
- Vérifier régulièrement le serrage des composants.

Contenu **NOTE:** Le produit réel peut changer de l'illustration.



Pare-insectes



Vis (4)



Rondelle (4)



Tampons à l'alcool (4)



Butoirs (4)

Contenu - ensemble de 3 morceaux



Pare-insectes

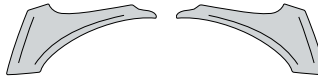

protecteur d'amortisseur (2)



Vis (4)



Rondelle (4)



Tampons à l'alcool (4)



Butoirs (4)

Outils nécessaires



Fournitures pour lavage de voiture



Serviette propre

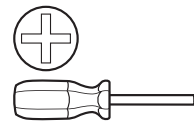

Tournevis Phillips

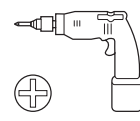

Tournevis De Puissance

Préparation pour la peinture/l'installation

- Il est recommandé de procéder à un essai pour s'assurer que le positionnement et l'ajustement sont corrects.
- Vérifier l'ajustement des pièces avant peinture, car nous n'acceptons pas le retour de pièces modifiées ou peintes.
- Laver les glissières de glaces de la portière du véhicule pour éliminer toute poussière et tous débris.
- Sécher les glissières avec une serviette propre.

Étapes d'installation

REMARQUE : La méthode d'application peut être légèrement différente de celle représentée par les illustrations.

Ouvrir le capot.

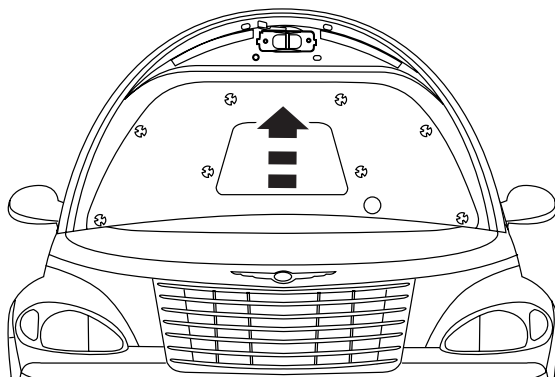

1

Nettoyer la surface de montage, sur le dessous du capot, avec un tampon à l'alcool.

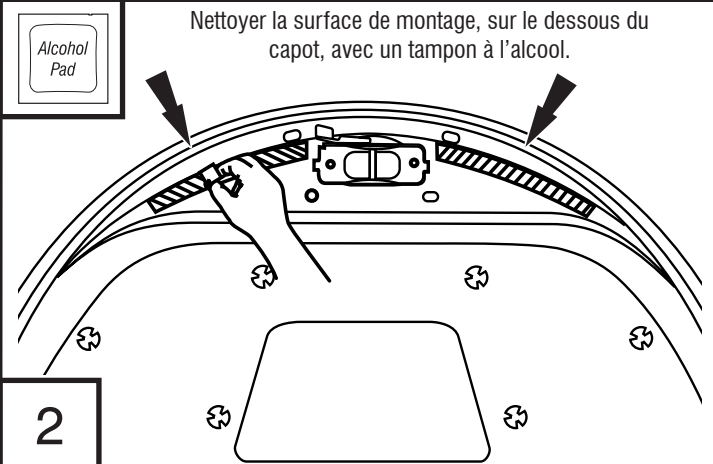

2

Étapes d'installation

REMARQUE : La méthode d'application peut être légèrement différente de celle représentée par les illustrations.

Décoller 5 cm (2 po) de protection d'adhésif de chacune des rebords du pare-insectes.

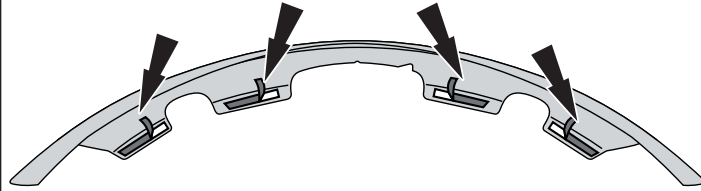

3

Aligner le point central du pare-insectes et le centre du capot. Appuyer fermement pour faire adhérer au capot la partie précédemment exposée du ruban et vérifier la position.

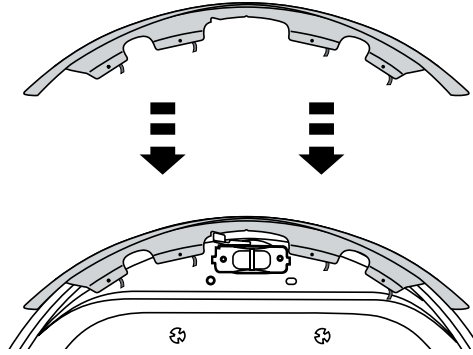

4

Retirer la protection d'adhésif restante en tirant sur ses extrémités libres.

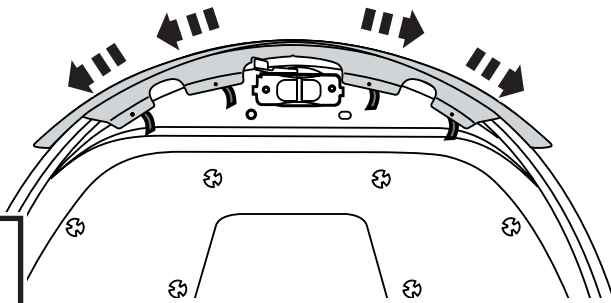

5

Appuyer fermement tout le long des rebords du ruban adhésif pour en assurer une bonne adhésion.

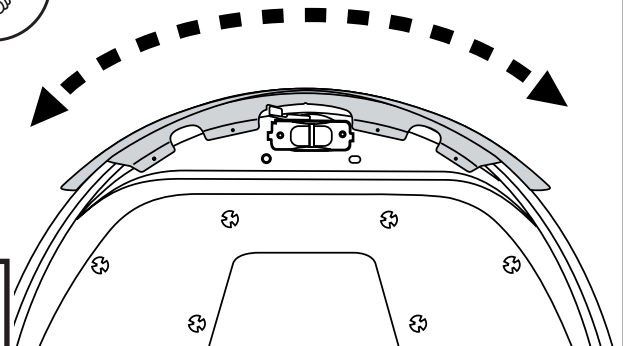

6

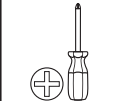
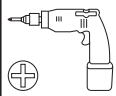

OPTIONNEL : Installer (4) vis taraudeuses dans les trous du pare-insectes. Un tournevis électrique est recommandé mais, une fois la vis enfoncée dans le panneau intérieur métallique, utiliser un tournevis cruciforme ordinaire pour achever de la visser.

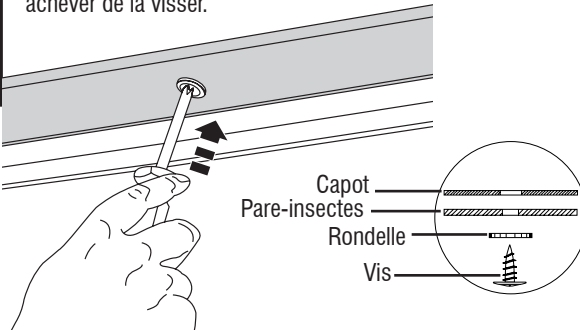

7

Fermer le capot.

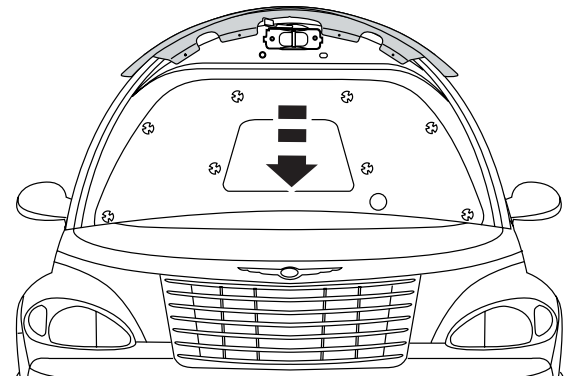

8

Installation de la protection d'aile

Nettoyer la surface de montage, au-dessus des phares et à côté de la calandre.

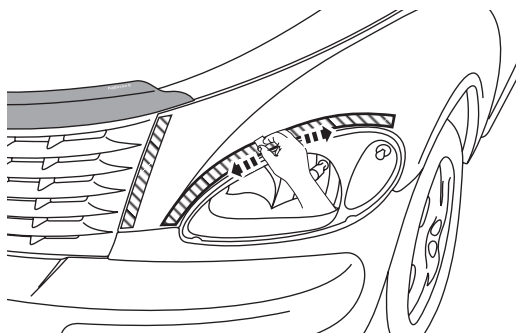

9

Décoller 5 cm (2 po) de protection d'adhésif de chacune des extrémités de la protection de l'aile.

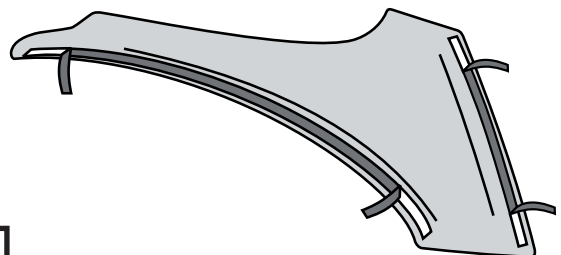

10

Étapes d'installation

REMARQUE : La méthode d'application peut être légèrement différente de celle représentée par les illustrations.

Aligner la protection de l'aile et l'aile. Appuyer fermement pour faire adhérer sur l'aile la partie précédemment exposée du ruban et vérifier la position.

11

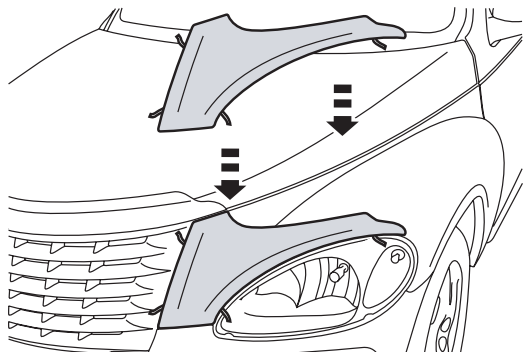

Retirer la protection d'adhésif restante en tirant sur ses extrémités libres.

12

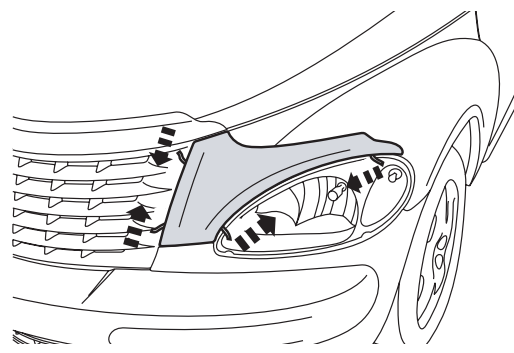

Press firmly along tape flanges to ensure proper adhesion.



13

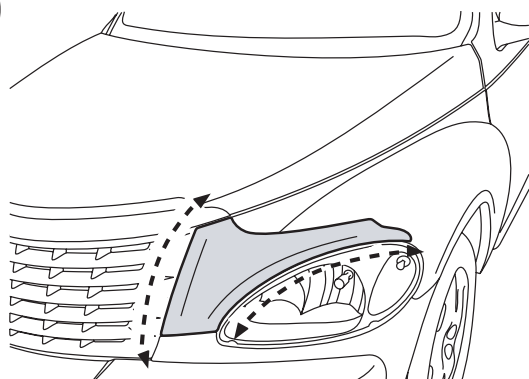

Appliquer les butoirs comme indiqué. Répéter les étapes 9 à 14 du côté passager.



14

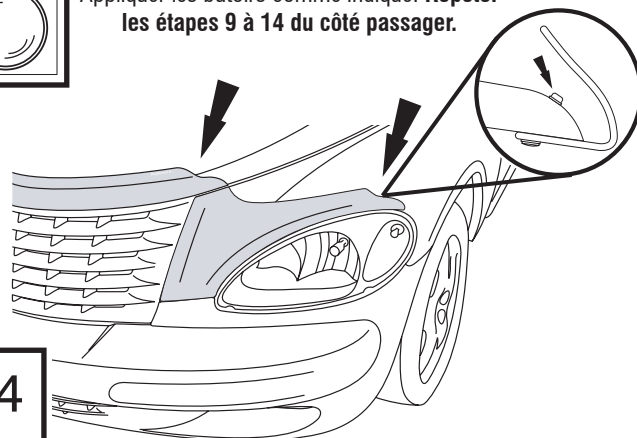

Entretien et nettoyage

- Laver exclusivement avec de l'eau savonneuse et sécher avec un chiffon propre.

Félicitations !

Vous avez acheté l'un des nombreux produits de qualité Auto Ventshade™ fabriqués par Lund International, Inc. Nous sommes extrêmement fiers de nos produits et souhaitons que vous tiriez des années de satisfaction de votre investissement. Nous avons pris toutes les mesures nécessaires pour assurer que ce produit est d'une qualité supérieure en ce qui concerne l'ajustement, la durabilité, la finition et la facilité d'installation.



AUTO VENTSHADE™

Lund International, Ventshade Accessories Division

655 Raco Drive, Lawrenceville, GA 30045, USA

800-241-7219 • Fax 770-339-5839 • Visitez notre site lundinternational.com



© 2005 Lund International, Inc. Tous droits réservés.
Auto Ventshade™, le logo Auto Ventshade™ et le logo AVS™ sont des marques déposées de Lund International, Inc.





Bugflector® - Bugflector II® - Carflector®

Para una instalación adecuada y el mejor ajuste posible, lea todas las instrucciones ANTES de comenzar. Si desea recibir asistencia técnica u obtener piezas faltantes, llame al Servicio al cliente al 1-800-241-7219.

Información importante de seguridad



- PRECAUCIÓN - Antes de conducir, asegúrese de que la visera deflectora esté correctamente anclada al vehículo.
- No utilice servicios automáticos de limpieza de vehículos que utilizan cepillos.
- No utilice limpiadores al solvente de ningún tipo.
- Compruebe periódicamente que todos los componentes estén ajustados.

Contenido

NOTA: El producto real puede variar de la ilustración.



Cubierta para capó



Tornillos (4)



Arandela (4)



Paños esterilizados (4)



Soporte x 4

Contenido - sistema de 3 pedazos



Cubierta para capó

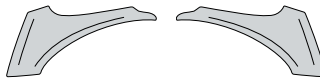

protector de la defensa (2)



Tornillos (4)



Arandela (4)



Paños esterilizados (4)



Soporte x 4

Herramientas necesarias



Equipo de limpieza de vehículos

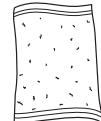

Toalla limpia

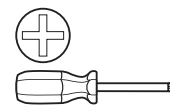

Destornillador Phillips

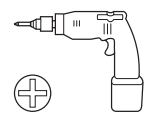

Destornillador De la Energía

Preparación antes de pintar o instalar

- Se recomienda realizar un ajuste de prueba para asegurar el posicionamiento y ajuste correctos.
- Compruebe que las piezas se ajusten correctamente antes de pintarlas, ya que no aceptaremos la devolución de piezas modificadas o pintadas.
- Lave los canales de la ventanilla del vehículo para quitar los desechos y la suciedad.
- Seque los canales de la ventanilla con una toalla limpia.

Pasos de instalación

NOTA: El uso real puede variar levemente de ilustraciones.

Abra el capó.

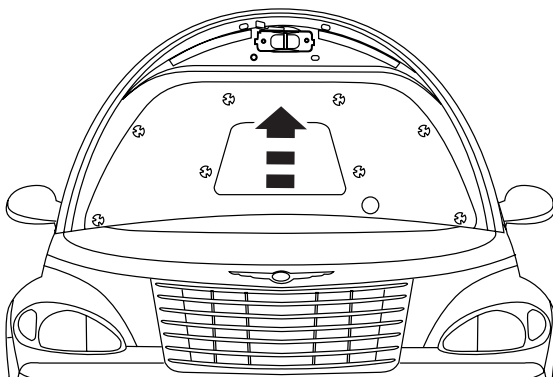

1

Limpie el lugar de colocación en la parte inferior del capó con un paño esterilizado.

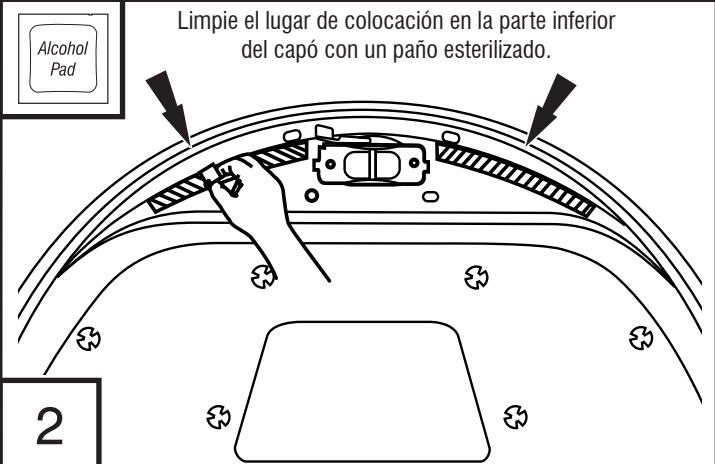

2

Pasos de instalación

NOTA: El uso real puede variar levemente de ilustraciones.

Exponga 2" (5 cm) de cinta protectora en cada extremo de los rebordes de la cubierta para capó.

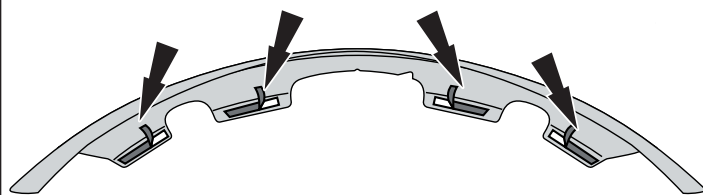

3

Alinee el centro de la cubierta para capó con el centro del capó. Presione firmemente para fijar la cinta expuesta y verifique la posición.

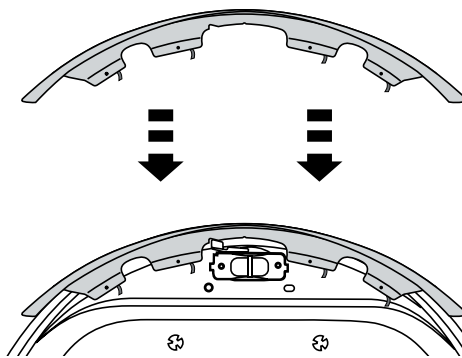

4

Retire las cintas protectoras tirando de los extremos libres.

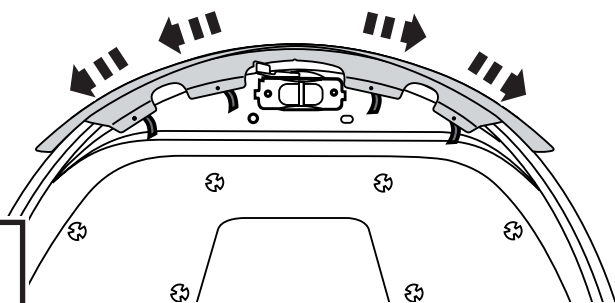

5

Presione firmemente sobre los rebordes para asegurarse de que se adhieran correctamente.

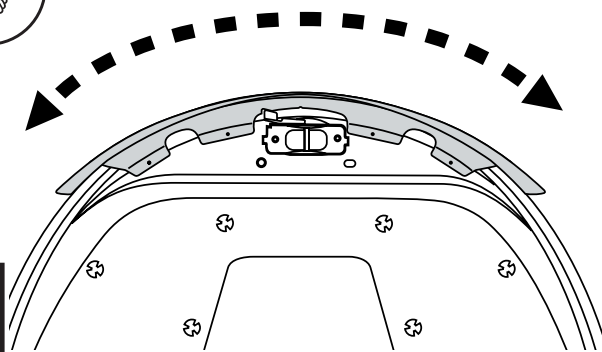

6

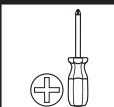
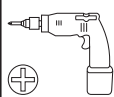

OPCIONAL: Coloque (4) tornillos autorroscantes en los orificios en la cubierta para capó. Se recomienda el uso de un destornillador eléctrico; sin embargo, una vez que el tornillo se introduzca en el panel metálico interior, deberá utilizar un destornillador Phillips manual hasta terminar el trabajo.

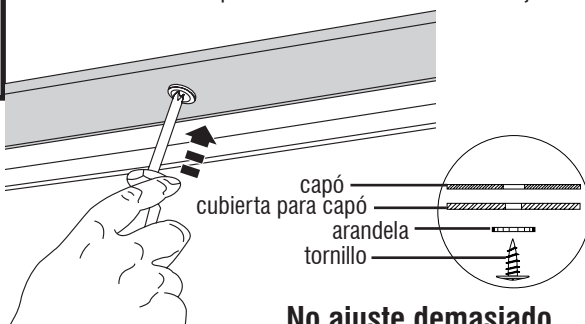

No ajuste demasiado

7

Cierre el capó.

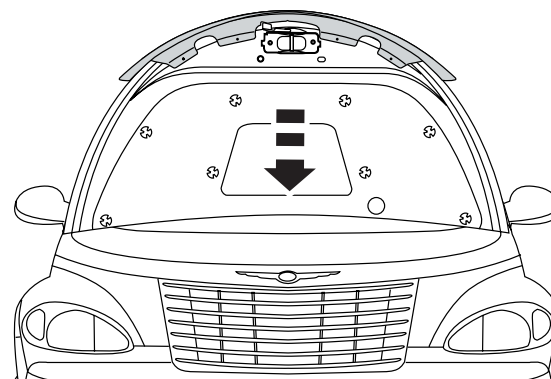

8

Instalación del protector de guardabarros

Limpie el lugar de colocación sobre los faros y a los lados de la parrilla.

Alcohol Pad

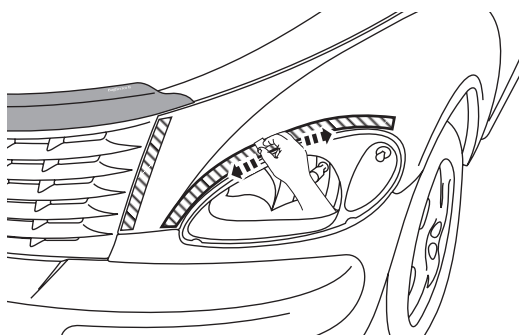

9

Exponga 2" (5 cm) de cinta protectora en cada extremo del protector de guardabarros.

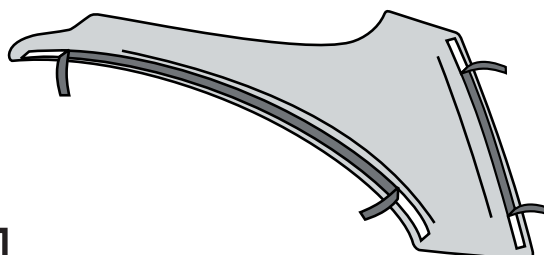

10

Pasos de instalación

NOTA: El uso real puede variar levemente de ilustraciones.

Alinee el protector de guardabarros con el guardabarros.
Presione firmemente para fijar la cinta expuesta al guardabarros y verifique la posición.

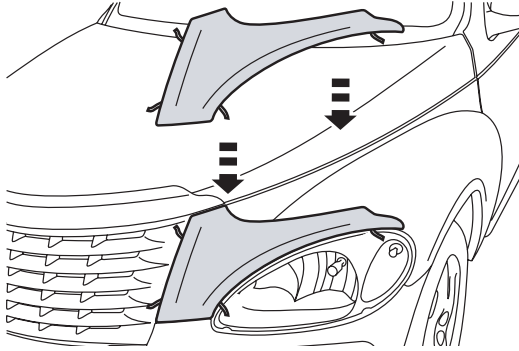

11

Retire las cintas protectoras tirando de los extremos libres.

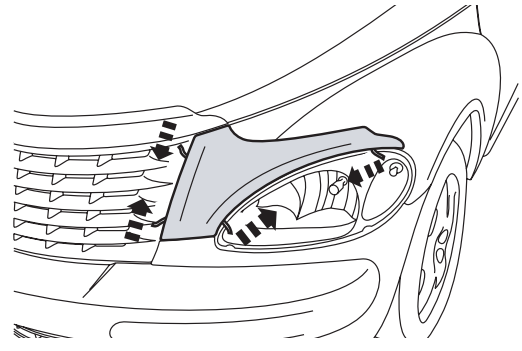

12

Presione firmemente sobre los rebordes para asegurarse de que se adhieran correctamente.

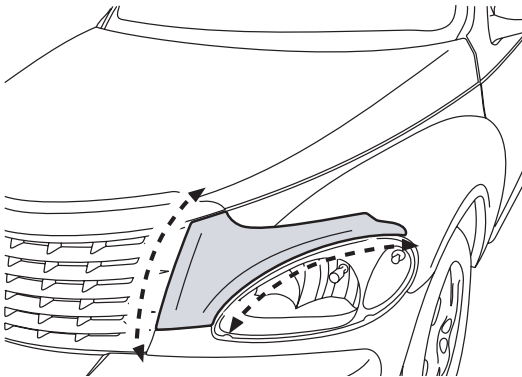

13

Coloque los soportes como se indica.
Repita los pasos 9 a 14 para el lado del acompañante.

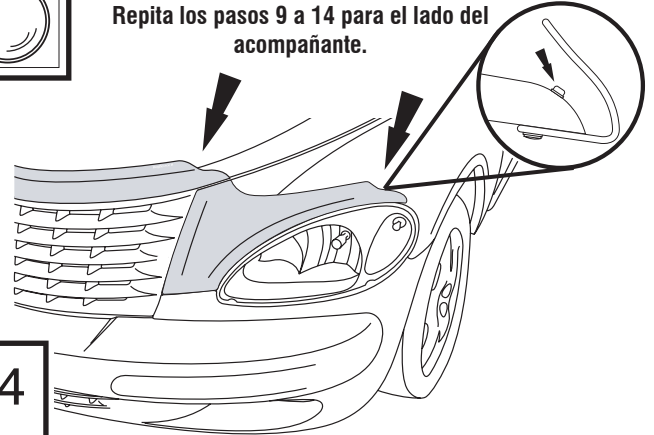

14

Cuidado y limpieza

- Limpie solamente con agua jabonosa tibia y seque con un paño limpio.

Felicidades

Usted ha comprado uno de los tantos artículos de calidad de Auto Ventshade™ ofrecidos por Lund International, Inc. Nuestros productos son nuestro mayor orgullo. Deseamos que disfrute de años de satisfacción con su inversión. Hemos realizado todos los esfuerzos para asegurarnos de que su producto sea de la mejor calidad en cuanto a ajuste, durabilidad, acabado y facilidad de instalación.



AUTO VENTSHADE™

Lund International, Ventshade Accessories Division

655 Raco Drive, Lawrenceville, GA 30045

800-241-7219 • Fax 770-339-5839 • Visite nuestro sitio Web: lundinternational.com



© 2005 Lund International, Inc. Todos los derechos reservados.
Auto Ventshade™, el logo de Auto Ventshade™ y el logo de AVS™ son marcas comerciales de Lund International, Inc.

