











2011-2013 GM 6.6L
(LML) Duramax
Positive Air Shutoff
2.5" CAC TUBES

P/N#	1036713
P/N#	1036713-M

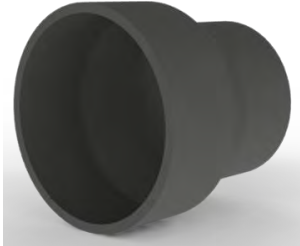
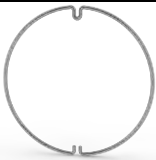
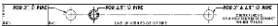
PLEASE READ ALL INSTRUCTIONS BEFORE INSTALLATION

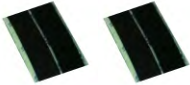
KIT CONTENTS:

Please check to make sure that you have all the parts listed in this kit **before** you start the disassembly your truck.





1036713 Kit Contents			
1302300	1302276	1302242	1302272
			
<i>Air Shutoff Valve</i>	<i>Elbow Silicone Boot</i>	<i>Wiring Harness</i>	<i>2.5"-3 1/4" Silicone Boot</i>
Qty: 1	Qty: 1	Qty: 1	Qty: 1
1302281	1302282	1407030	1405209
			
<i>2.5" PAS Bead Ring</i>	<i>PAS Drill Template</i>	<i>0350 Clamps</i>	<i>0300 Clamps</i>
Qty: 1	Qty: 1	Qty: 2	Qty: 2
1800060	1301381	1306710	1302285
			
<i>Velcro strips</i>	<i>Heat Shrink</i>	<i>Duramax Electronic Module</i>	<i>Solder</i>
Qty: 2 x 4"	Qty: 3"	Qty: 1	Qty: 5"

BD Engine Brake Inc.

Plant Address: 33541 MacLure Rd. Abbotsford, BC, Canada V2S 7W2

U.S. Shipping Address: 88-446 Harrison St, Sumas, WA 98295 U.S. Mailing Address: P.O. Box 231, Sumas, WA 98295

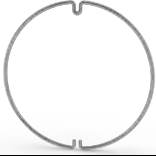
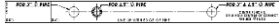
Phone: 604-853-6096 | Fax: 604-853-8749 | Internet: www.bd-power.com

1036713-M Kit Contents			
1302300	1302276	1302249	1302272
			
<i>Air Shutoff Valve</i>	<i>Elbow Silicone Boot</i>	<i>Wiring Harness</i>	<i>2.5"-3 1/4" Silicone Boot</i>
Qty: 1	Qty: 1	Qty: 1	Qty: 1
1302281	1302282	1407030	1405209
			
<i>2.5" PAS Bead Ring</i>	<i>PAS Drill Template</i>	<i>0350 Clamps</i>	<i>0300 Clamps</i>
Qty: 1	Qty: 1	Qty: 2	Qty: 2

BD Engine Brake Inc.

Plant Address: 33541 MacLure Rd. Abbotsford, BC, Canada V2S 7W2

U.S. Shipping Address: 88-446 Harrison St, Sumas, WA 98295 U.S. Mailing Address: P.O. Box 231, Sumas, WA 98295

Phone: 604-853-6096 | Fax: 604-853-8749 | Internet: www.bd-power.com

WELCOME

Thank you for purchasing a BD positive air shutoff. This manual is divided into different areas to assist you with your installation and operation of your positive air shutoff.

This product is a safety product and should be tested often.

Installation should occur on a vehicle properly secured to prevent rolling.

TABLE OF CONTENTS

REQUIRED TOOLS.....	4
MAINTENANCE.....	5
INSTALLATION with OVER SPEED ELECTRONICS (1036713).....	5
INSTALLATION without OVER SPEED ELECTRONICS (1036713-M).....	16
WIRING DIAGRAM with OVER SPEED ELECTRONICS (1036713).....	26
WIRING DIAGRAM without OVER SPEED ELECTRONICS (1036713-M).....	27
BEAD RING AND DRILL JIG INSTALLATION.....	28
RESETTING THE VALVE.....	29
SETUP, TESTING AND VERIFICATION with OVER SPEED ELECTRONICS.....	30
Automatic Mode (Pre Configured RPM).....	30
Manual Mode (User Configured RPM).....	32
TESTING FLOW CHART with OVER SPEED ELECTRONICS.....	35
TESTING FLOW CHART without OVER SPEED ELECTRONICS.....	36
LED OPERATION.....	37

REQUIRED TOOLS

- Frequency/Voltmeter (Suggested)
- Drill
- 1/8", 11/32" Drill Bit
- 1/2" Unibit
- Electrical Tape
- Soldering Iron
- Needle Nose Pliers
- Air or Manual Ratchet
- 7/16", 1/2" Sockets
- Wire Strippers
- Heat Gun
- Band Saw or reciprocating saw or cutoff wheel.

BD Engine Brake Inc.

Plant Address: 33541 MacLure Rd. Abbotsford, BC, Canada V2S 7W2

U.S. Shipping Address: 88-446 Harrison St, Sumas, WA 98295 U.S. Mailing Address: P.O. Box 231, Sumas, WA 98295

Phone: 604-853-6096 | Fax: 604-853-8749 | Internet: www.bd-power.com

MAINTENANCE

The only maintenance required is to test the valve operation at regular intervals. Please see the testing section later in the manual for the correct procedure.

INSTALLATION with OVER SPEED ELECTRONICS (1036713)



VEHICLE SHOULD BE SAFELY SECURED BEFORE INSTALLATION.

1. Block the wheels of the vehicle to prevent the vehicle from rolling.

Open the hood.

2. You will need to remove the driver's side Charge Air Cooler (CAC) tube. Loosen both clamps and disconnect from the turbo inlet connection, then disconnect from the CAC and maneuver it from the vehicle.

3. With the driver's side CAC tube removed, lay it flat on a work bench.

First identify the turbo inlet side and the CAC outlet side of the tube.



BD Engine Brake Inc.

Plant Address: 33541 MacLure Rd. Abbotsford, BC, Canada V2S 7W2

U.S. Shipping Address: 88-446 Harrison St, Sumas, WA 98295 U.S. Mailing Address: P.O. Box 231, Sumas, WA 98295

Phone: 604-853-6096 | Fax: 604-853-8749 | Internet: www.bd-power.com

4. You will need to make one cut 1 1/2" from the tangent edge of the pipes second bend from the turbo inlet side.

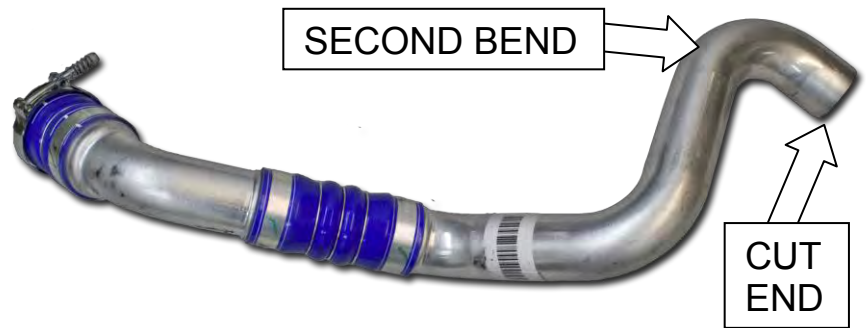
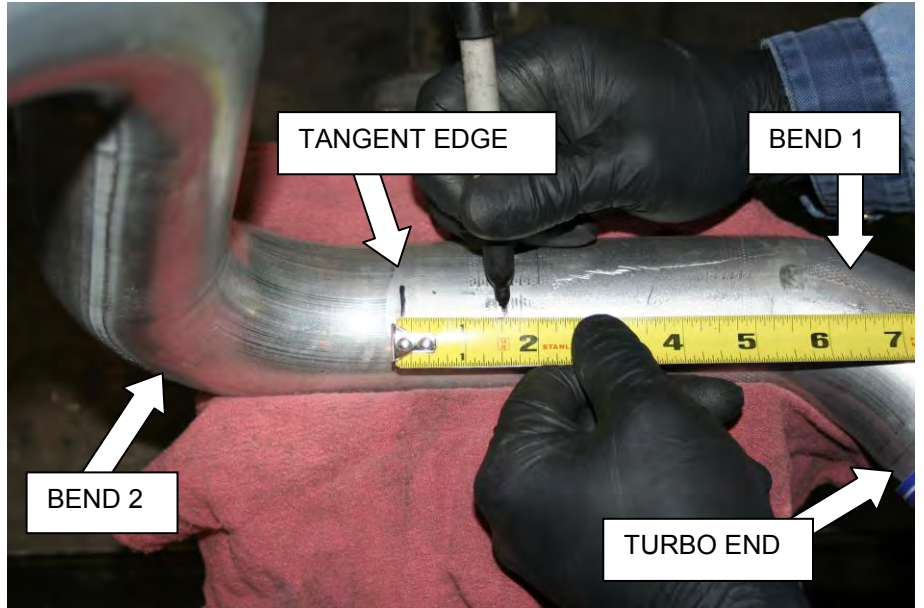

5. With the pipe cut, you will now need to drill a couple of holes to secure the boot bead on both ends of the pipe.

6. Firstly, remove the backing from drill template sticker and wrap around pipe. The edge of the sticker should line up with the edge of the pipe.

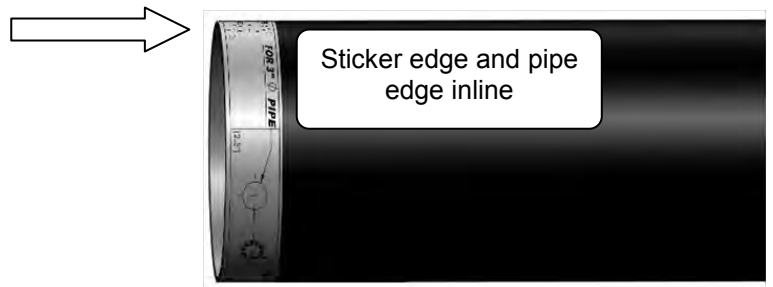
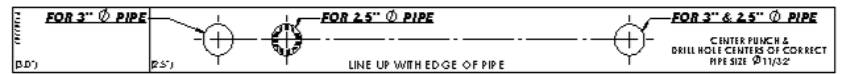

YOU WILL USE THE 2.5" TEMPLATE MARKS

For the 2.5" pipe the sticker should wrap perfectly around the pipe, the start of the sticker should meet the end of the sticker.

7. With the sticker in place use a center punch and then use a $\text{\O}1/8$ " drill bit and drill a hole in the center of the holes marked "**For 2.5"Ø**".

There will be two holes and they should be perfectly 180° inline with each other through the pipe.

DO NOT DRILL COMPLETELY THROUGH THE PIPE AND OUT THE OTHER END. YOU WILL NEED TO DRILL ONE SIDE THEN ROTATE, AND THEN DRILL THE OTHER SIDE.

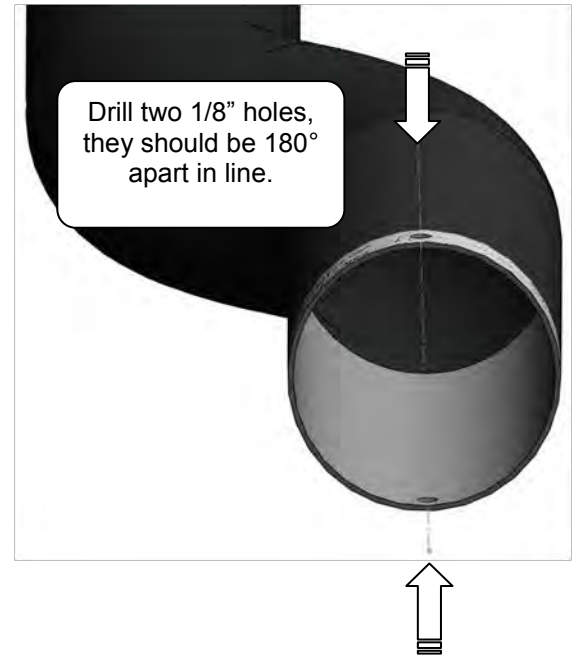

8. Once the pilot holes are drilled you will need to drill an $\text{\O}11/32$ " hole through the pilot holes.

You can now remove the sticker.

You must deburr the inside of the drilled holes.

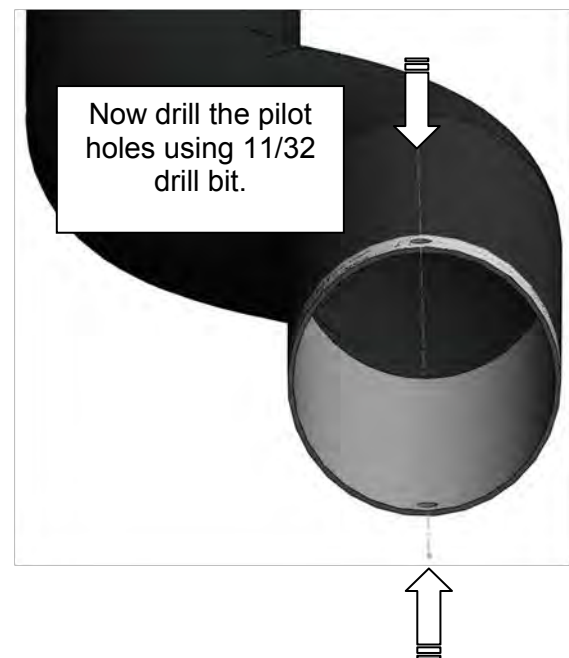

9. Once the holes are drilled, install the ring bead around the pipe. Lock each end of the ring bead into each hole.

You can use a needle nose plier to tweak or adjust the ring fit slightly.

Be careful not to bend the ring bead too much as you will weaken it.

Note the ring bead does not have to be perfectly tight or snug around the pipe, as we will be installing a silicone boot over top of it.

With the ring bead in place, you should not be able to pull the ring bead off axially from the tube.



10. Slide one 0300 clamp onto the pipe then install the step boot (#1302272) onto the pipe over the bead ring.

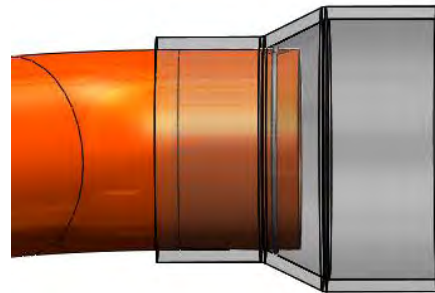

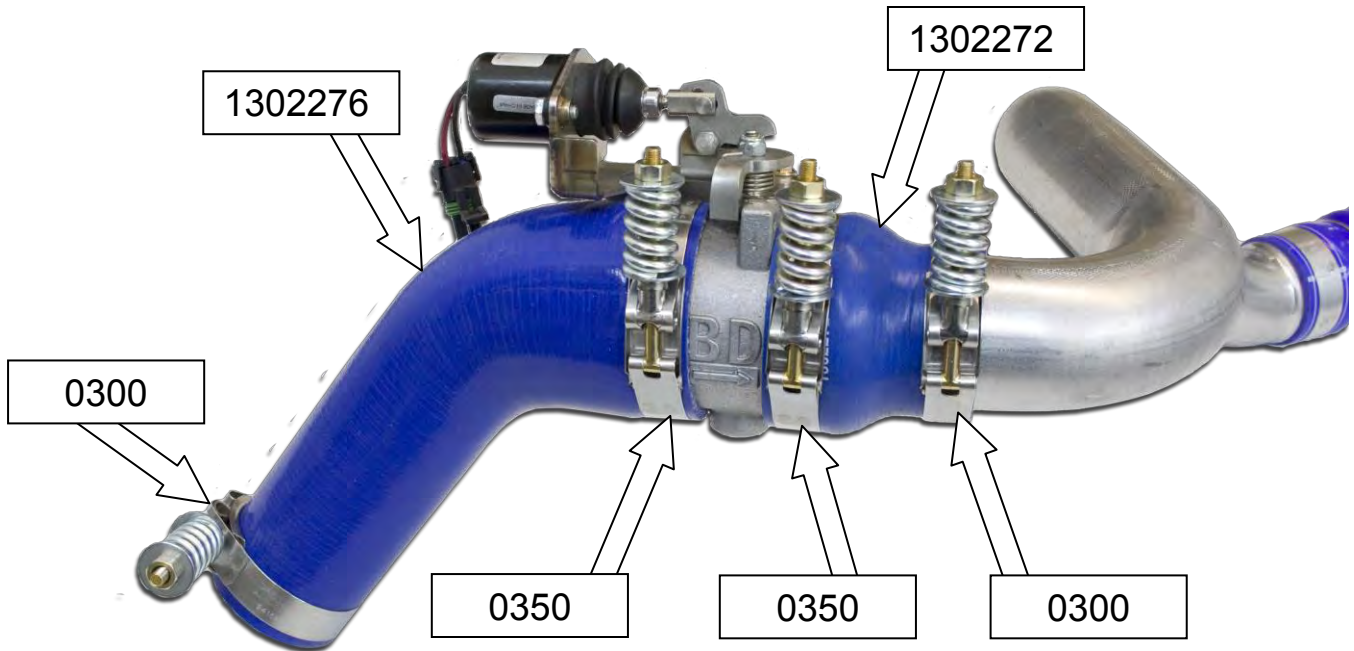

11. Once the boot and clamp are in place you can install the valve ensuring the flow orientation arrow on the side of the casting points towards the CAC. Then install the elbow boot with the supplied clamps. Leave all clamps loose until proper in vehicle fitment can be determined.

12. Install PAS tube assembly into the vehicle CAC side first.
 Note that you will need to rotate the tubes you achieve perfect alignment. Once you are happy with fit and the PAS unit will not contact any other components or vibrations. Tighten all spring clamps until the spring is spring bound.

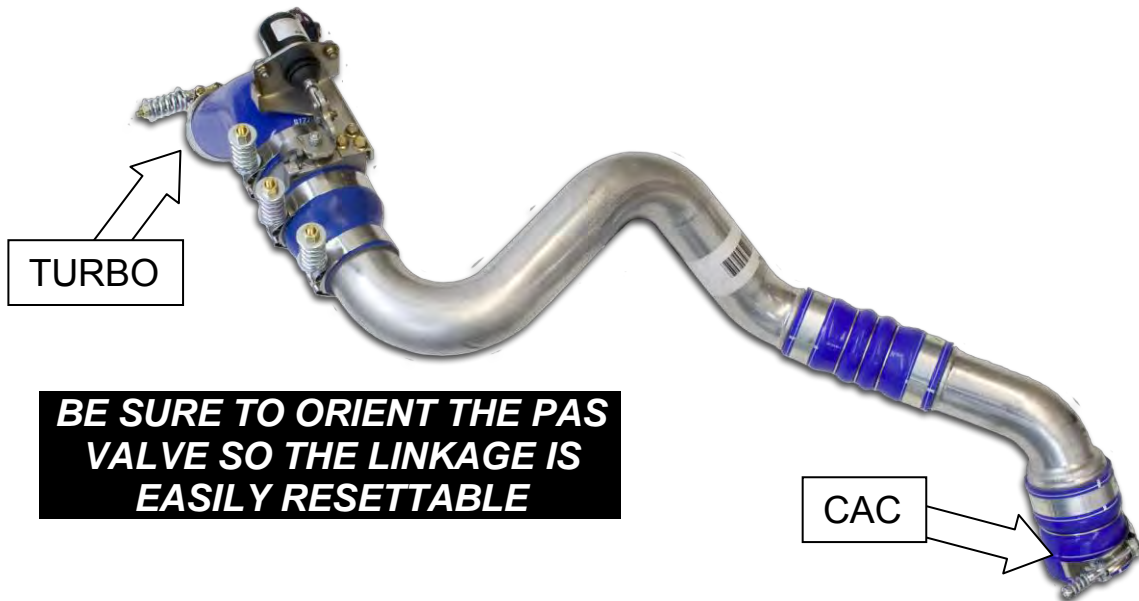

13. Lay out supplied wiring harness over top of the engine.



14. You will then need to route the switch through the firewall on the driver's side (note you will need to remove the switch from the harness to accomplish this). See wiring diagram on page 26

Choose a highly visible location for the switch and mount it to the dash.



15. Using a 1/8" drill, drill a pilot hole in the location you have selected for the switch to be mounted.

16. Finally using a 1/2" UNIBIT drill bit, drill an exact 1/2" round hole.

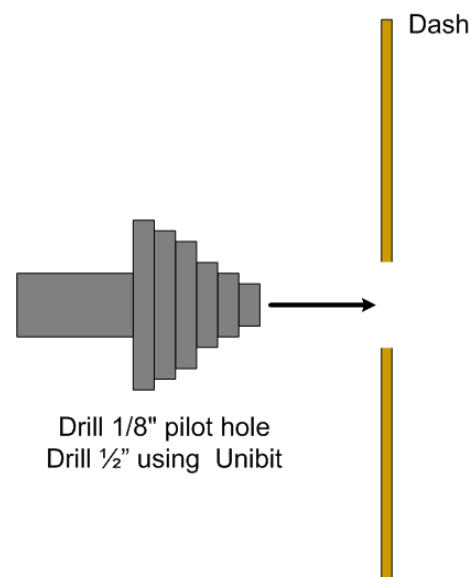

BD Engine Brake Inc.

Plant Address: 33541 MacLure Rd. Abbotsford, BC, Canada V2S 7W2

U.S. Shipping Address: 88-446 Harrison St, Sumas, WA 98295 U.S. Mailing Address: P.O. Box 231, Sumas, WA 98295

Phone: 604-853-6096 | Fax: 604-853-8749 | Internet: www.bd-power.com

17. Once you have the mounting hole drilled, insert the switch from the backside.

Reinstall the correct wires to the correct switch terminals.

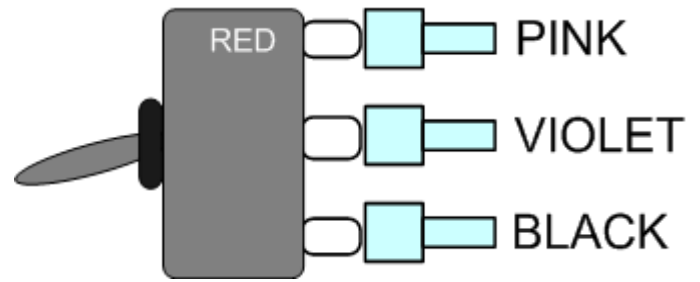

18. Mount the switch so that the groove on the thread boss is facing down.

Adjust the HEX washer/nut so that the switch threads do not protrude an unsightly amount.

Switch install with decal

Apply the supplied decal to the dash and tighten the round plastic nut.

Switch install with Guard

Install the switch guard onto the switch by aligning the tab with the groove on the thread boss.

Then tighten on the round plastic nut and apply the decal to the switch guard.

Switch install with Decal

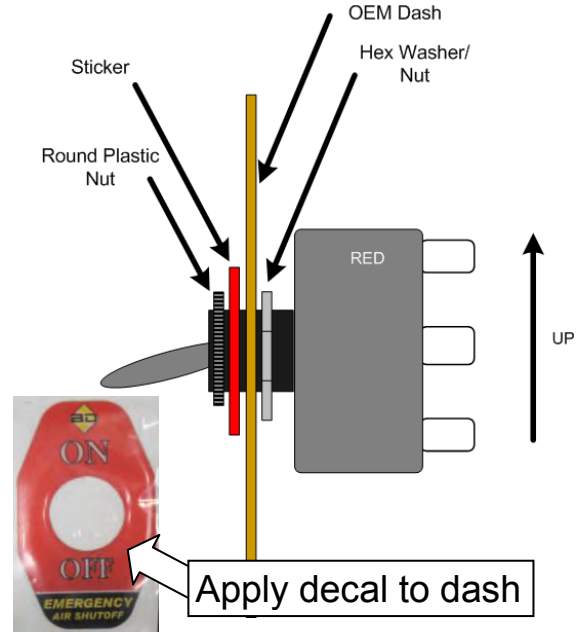

Switch Install with Guard

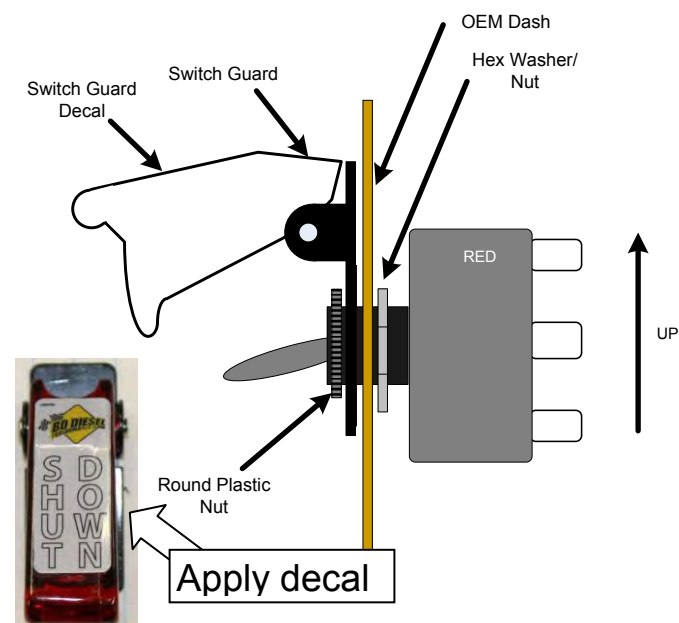

19. Now underneath the hood locate and connect the weather pack connector on the wiring harness to the solenoid on the PAS valve. See page 26 for more info.

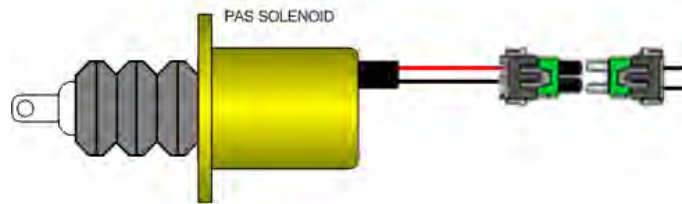

20. You will now need to locate the CRANKSHAFT SENSOR Wire.

Locate the ECM Connector #3.

21. This connector will have 73 pins, locate pin 61 and follow the direction in step 22.

Connector Part Information

Harness:
Engine Chassis

OEM: 12603597

Service: 13574948

Description: 73-Way F
MX123 34566 Series (GY)

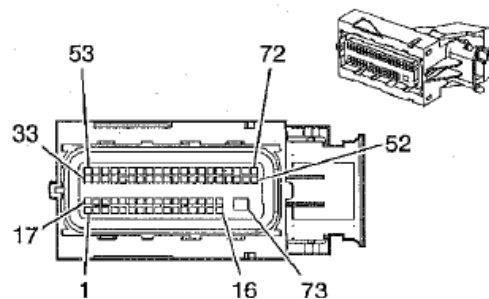

Pin	Wire Color	Circuit No.	Function
54	0.5 L-GN/BK	5746	Exhaust Gas Recirculation Valve Motor Low Signal
55	0.5 OG/BK	5764	Exhaust Gas Recirculation Valve Motor High Signal
56	0.8 BN	582	Throttle Actuator Control Close
57	0.8 YE	581	Throttle Actuator Control Open
58	0.5 OG/BK	3656	EGR Cooler Bypass Motor Close Control (LML)
59	0.5 L-GN	3655	EGR Cooler Bypass Motor Open Control (LML)
60	0.5 GY/BK	6272	Low Reference
61	0.5 WH/BK	6271	CKP Sensor Signal
62	0.5 D-GN	485	Throttle Position Sensor

22. Being that the RPM signal is critical you will need to solder the connection.

Using wire strippers create a 1" window/gap in insulation of the wire.

Then strip about 1" of insulation of the RPM signal wire of the BLUE wire from the PAS wiring harness.

Wrap the copper wire around the factory RPM signal wire and solder this connection.

Then use electrical tape to wrap this connection so that it is water tight.

You can also cut the factory crank signal wire and use heat shrink tubing if you would like.

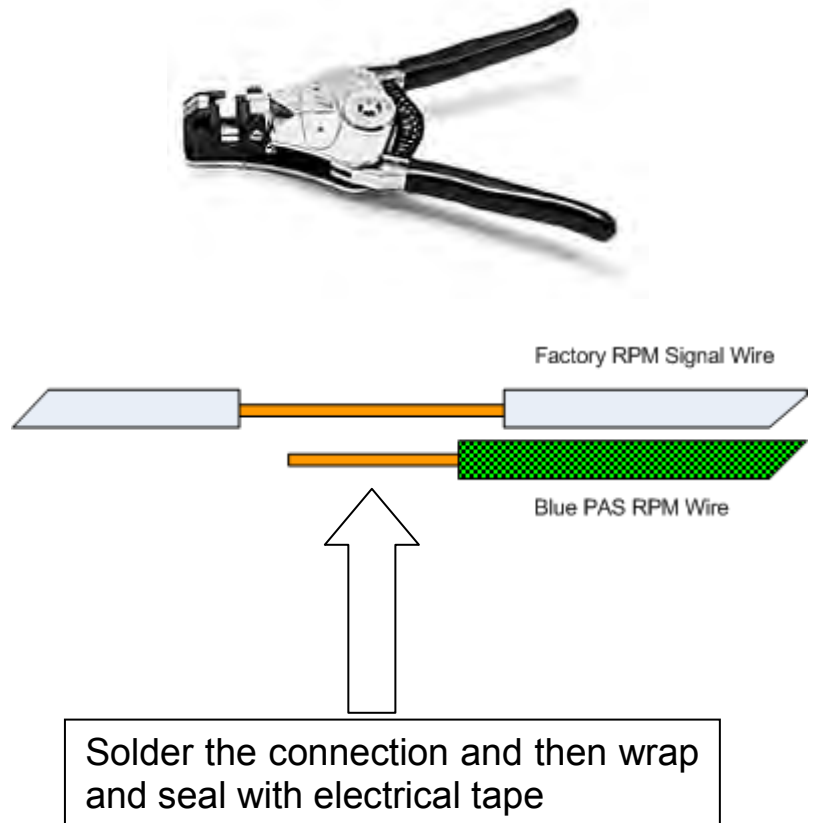

23. Run the BLACK and RED wires on the harness to the battery and connect to respective power and ground connections.

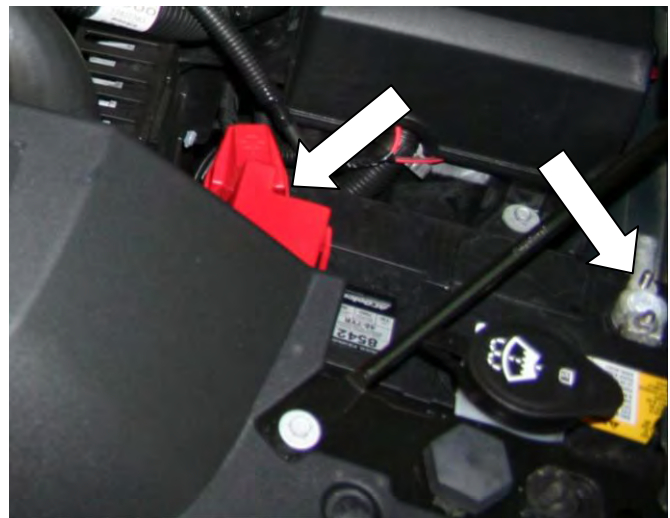

BD Engine Brake Inc.

Plant Address: 33541 MacLure Rd. Abbotsford, BC, Canada V2S 7W2

U.S. Shipping Address: 88-446 Harrison St, Sumas, WA 98295 U.S. Mailing Address: P.O. Box 231, Sumas, WA 98295

Phone: 604-853-6096 | Fax: 604-853-8749 | Internet: www.bd-power.com

24. For the last connection you will need to locate ignition power. This will power the automatic over speed control box LED switch. Note that the unit can still be activated manually with the switch at any time.

Locate the battery junction box at the driver's side mid of the engine compartment.

Open the junction box and locate the appropriate fused ignition power circuit (see table below). Install fuse tapper on to fuse, reinstall fuse. Connect yellow lead wire with flag connector to this new connection. Route wire out of the box and close lid.

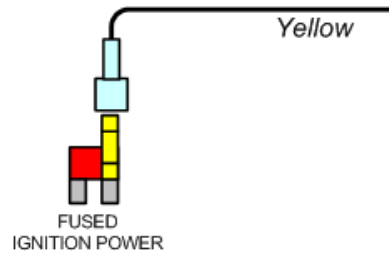
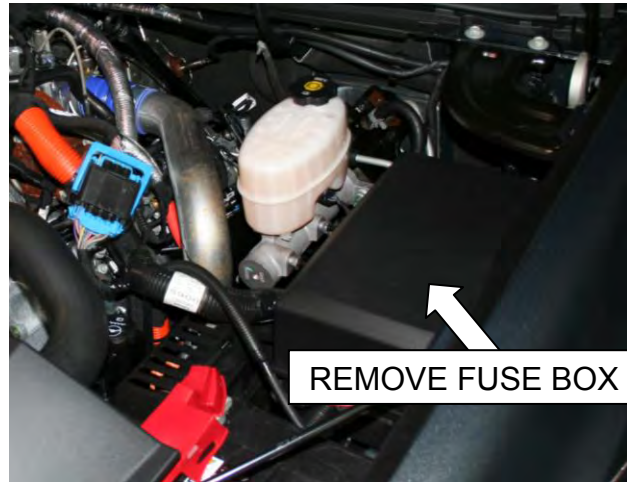

AUX HVAC-IGN #45 (10AMP)

Pin	Wire Color	Circuit No.	Function
39	RDO Fuse	15A	Digital Radio Receiver (U2K), Radio, Rear Seat Audio (RSA) Control (UK6), Chime Module (UL5)
40	MISC IGN Fuse	10A	Auxiliary Body Control Module (XBCM) (EXP), Stop Lamp Switch, Transfer Case Shift Control Module (NQF or NQH), Trailer Brake Control Module (JL1)
41	L/GATE RELSE Fuse	15A	Not Used
42	AIRBAG BATT Fuse	15A	Inflatable Restraint Passenger Presence System (PPS) Module, Inflatable Restraint Sensing and Diagnostic Module (SDM), Inflatable Restraint Vehicle Roll-over Sensor (ASF)
43	IPC Fuse	10A	Body Control Module (BCM), Instrument Panel Cluster (IPC)
44	EXP/PTO Fuse	15A	Auxiliary Body Control Module (XBCM) (EXP) Power Take Off Relay (PTO)
45	AUX HVAC-IGN Fuse	10A	Instrument Panel Cluster (IPC), Inside Rearview Mirror (ISRVM), Heated Steering Wheel Module Control (KA9)
46	CHMSL Fuse	15A	Center High Mounted Stop Lamp (CHMSL)
47	REAR DEFOG Fuse	30A	Rear Window Defogger Grid

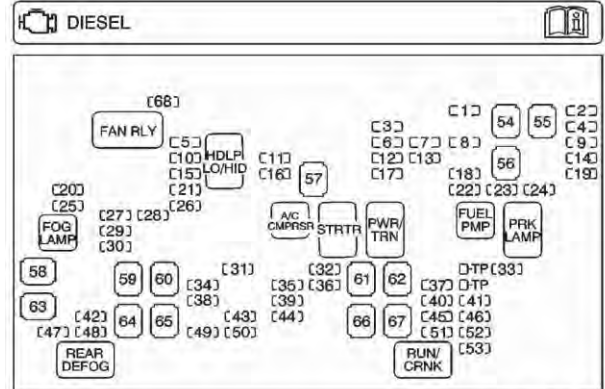

MINI FUSES MINI-FUSIBLES		J-CASE FUSES FUSIBLES JCASE
1 - ESC/ALC EXH (30A)	19 - ITBC (15A)	38 - AMP (30A)
2 - TRLR STOP LT (10A)	20 - HDLP WASH (20A)	39 - RDO (15A)
3 - ENG (15A)	21 - REAR WASH (15A)	40 - MISC IGN (10A)
4 - TRLR STOP RT (10A)	22 - TRLR PRK (15A)	41 - L/GATE RELSE (15A)
5 - FRT WASH (15A)	23 - LT PRK (15A)	42 - AIRBAG BATT (15A)
6 - FUEL HTR (15A)	24 - RT PRK (15A)	43 - IPC (10A)
7 - TCM-BATT (15A)	25 - FOG LAMP (15A)	44 - EXP/PTO (15A)
8 - ABS 2 (25A)	26 - HORN (15A)	45 - AUX HVAC-IGN (10A)
9 - TRLR BCK/UP (10A)	27 - HI HDLP	46 - CHMSL (15A)
10 - LO HDLP-LT (20A)	28 - DRL (15A)	47 - REAR DEFOG (30A)
11 - ECM-BATT (10A)	29 - HI HDLP-LT (10A)	48 - HTD MIR (15A)
12 - DSL ECM (30A)	30 - DRL 2 (15A)	49 - SEO B1 (15A)
13 - TRNS IGN 1 (15A)	31 - S/ROOF (30A)	50 - LTR (20A)
14 - VEH BCK/UP (10A)	32 - DLIS (2A)	51 - SEO/ALC (10A)
15 - LO HDLP-RT (20A)	33 - WPR (25A)	52 - HVAC-IGN (10A)
16 - A/C CMPRSR (10A)	34 - SEO B2 (30A)	53 - ECM-IGN (15A)
17 - EMC/THROT CONT (15A)	35 - EAP (15A)	54 - ALC/COMP (40A)
18 - FUEL PUMP (25A)	36 - HVAC BATT (10A)	55 - HEAVY DUTY ABS (60A)
	37 - AIRBAG IGN (10A)	56 - ABS-1 (40A)
		57 - STRTR (40A)
		58 - STUD-2 (30A)
		59 - LBEC1 (80A)
		60 - ELEC RUN BOARD (30A)
		61 - WSW/HTR (60A)
		62 - TREC (30A)
		63 - STUD-1 (40A)
		64 - MBEC1 (60A)
		65 - HVAC BLWR (40A)
		66 - LGM (30A)
		67 - LBEC2 (60A)

BD Engine Brake Inc.

Plant Address: 33541 MacLure Rd. Abbotsford, BC, Canada V2S 7W2

U.S. Shipping Address: 88-446 Harrison St, Sumas, WA 98295 U.S. Mailing Address: P.O. Box 231, Sumas, WA 98295

Phone: 604-853-6096 | Fax: 604-853-8749 | Internet: www.bd-power.com

25. Mount the electronic control unit on top of the junction/fuse box. Be sure to clean the mounting surface with alcohol before applying Velcro.

Connect the wiring harness to the electronic control unit.

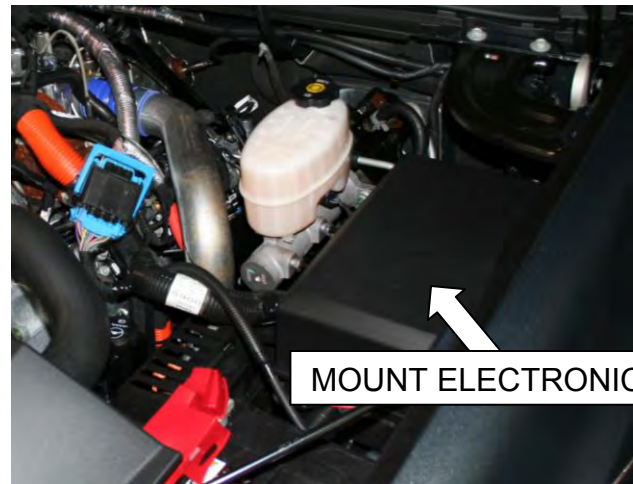

26. Double check all wiring connections and ensure wires are routed away from any heat sources and moving parts. And continue to the Setup, Testing and Verification with Over Speed Electronics section in this manual.

INSTALLATION without OVER SPEED ELECTRONICS (1036713-M)

VEHICLE SHOULD BE SAFELY SECURED BEFORE INSTALLATION.

1. Block the wheels of the vehicle to prevent the vehicle from rolling.

Open the hood.

2. You will need to remove the driver's side Charge Air Cooler (CAC) tube. Loosen both clamps and disconnect from the turbo inlet connection, then disconnect from the CAC and maneuver it from the vehicle.

3. With the driver's side CAC tube removed, lay it flat on a work bench.

First identify the turbo inlet side and the CAC outlet side of the tube.



4. You will need to make one cut 1 1/2" from the tangent edge of the pipes second bend from the turbo inlet side.

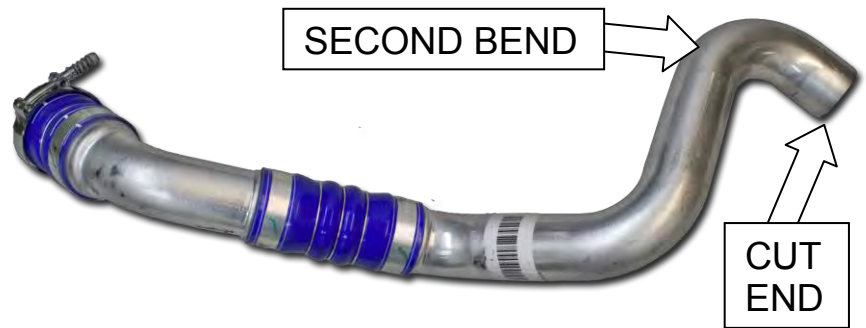
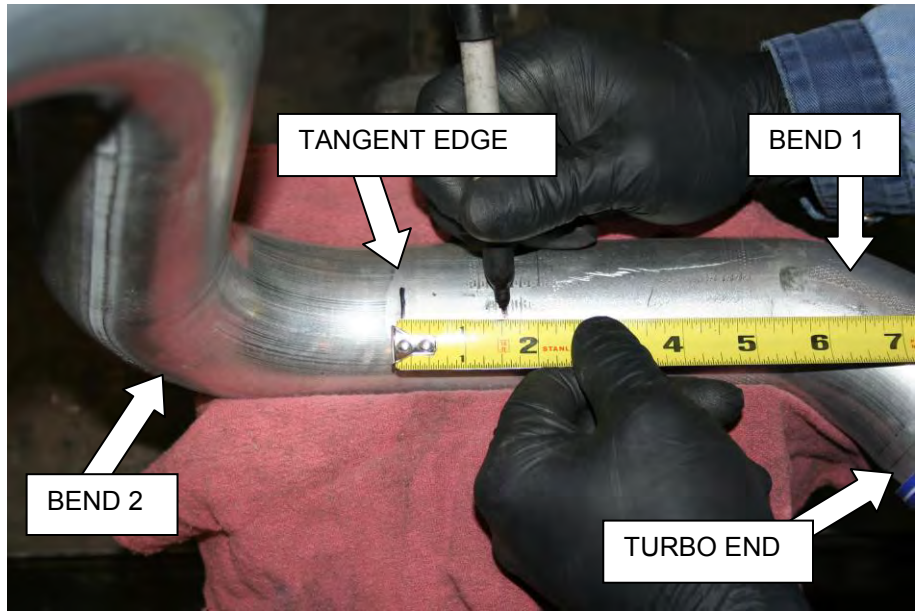

5. With the pipe cut, you will now need to drill a couple of holes to secure the boot bead on both ends of the pipe.

6. Firstly, remove the backing from drill Jig sticker and wrap around pipe. The edge of the sticker should line up with the edge of the pipe.

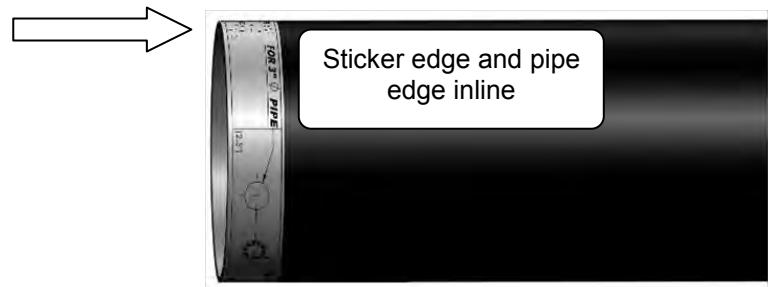
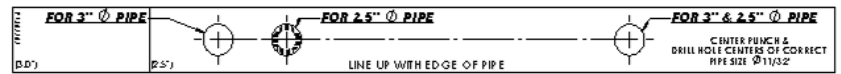

YOU WILL USE THE 2.5" TEMPLATE MARKS

7. For the 2.5” pipe the sticker should wrap perfectly around the pipe, the start of the sticker should meet the end of the sticker.

With the sticker in place use a center punch and then use a $\text{Ø}1/8$ ” drill bit and drill a hole in the center of the holes marked “For 2.5”Ø”.

There will be two holes and they should be perfectly 180° inline with each other through the pipe.

DO NOT DRILL COMPLETELY THROUGH THE PIPE AND OUT THE OTHER END. YOU WILL NEED TO DRILL ONE SIDE THEN ROTATE, AND THEN DRILL THE OTHER SIDE.

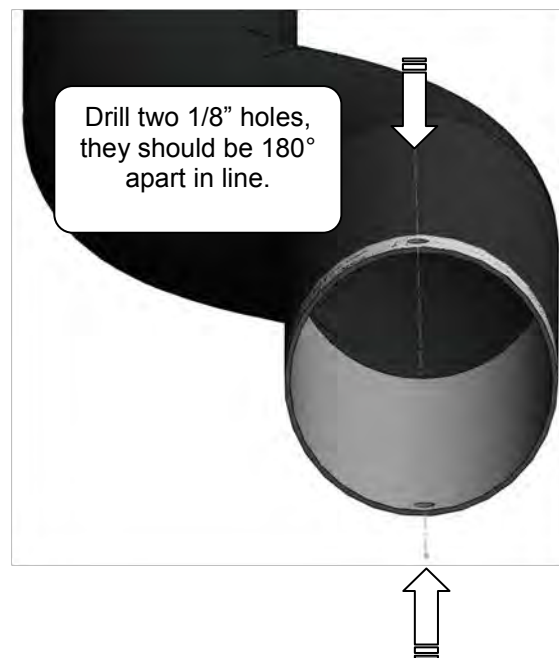

8. Once the pilot holes are drilled you will need to drill an $\text{\O}11/32$ " hole through the pilot holes.

You can now remove the sticker.

You must deburr the inside of the drilled holes.

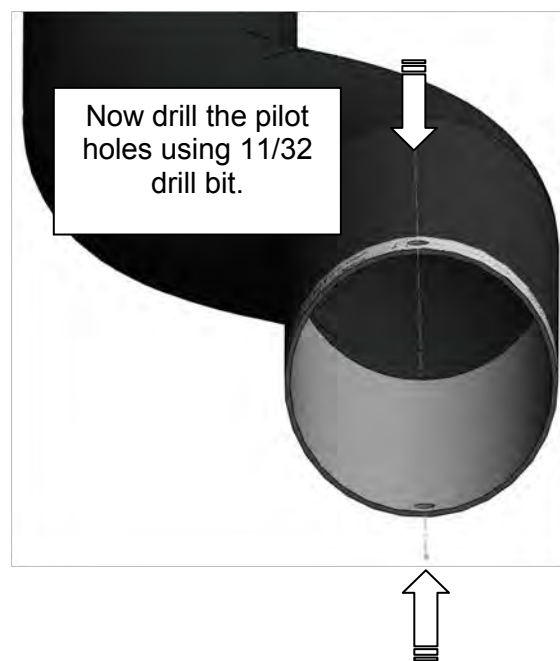

9. Once the holes are drilled, install the ring bead around the pipe. Lock each end of the ring bead into each hole.

You can use needle nose pliers to tweak or adjust the ring fit slightly.

Be careful not to bend the ring bead too much as you will weaken it.

Note the ring bead does not have to be perfectly tight or snug around the pipe, as we will be installing a silicone boot over top of it.

With the ring bead in place, you should not be able to pull the ring bead off axially from the tube.



10. Slide one 0300 clamp onto the pipe then install the step boot (#1302272) onto the pipe over the bead ring.

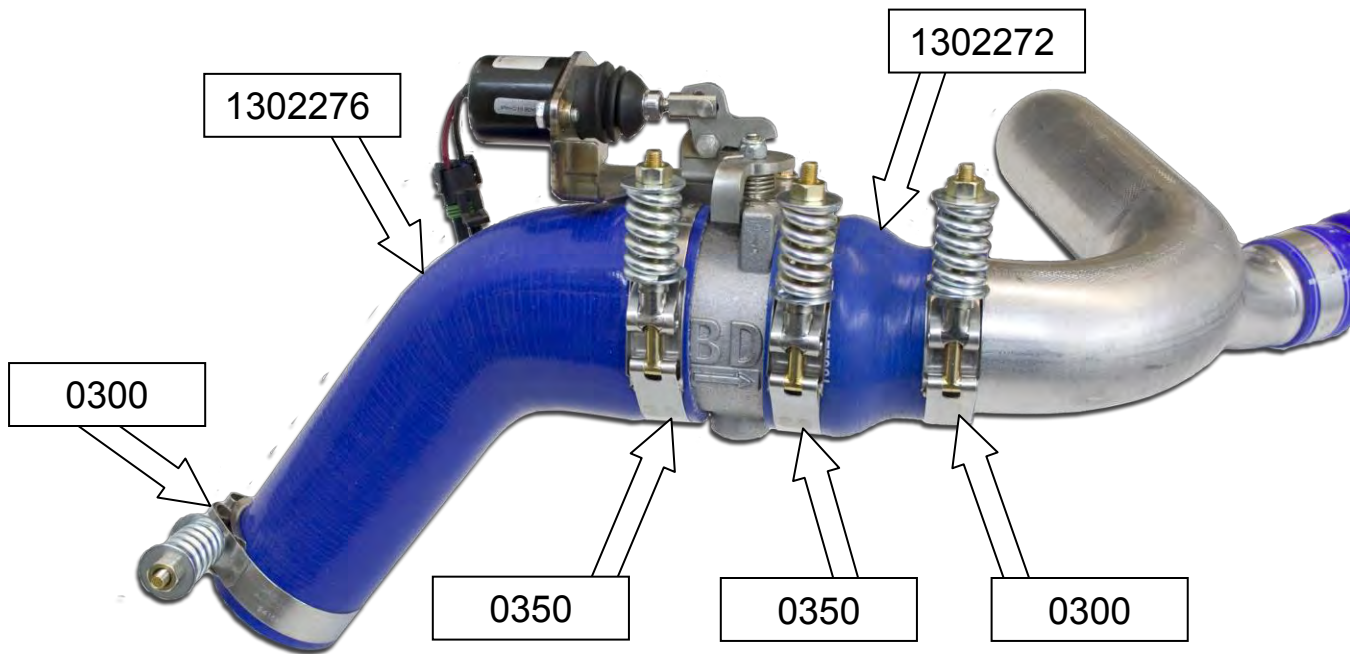
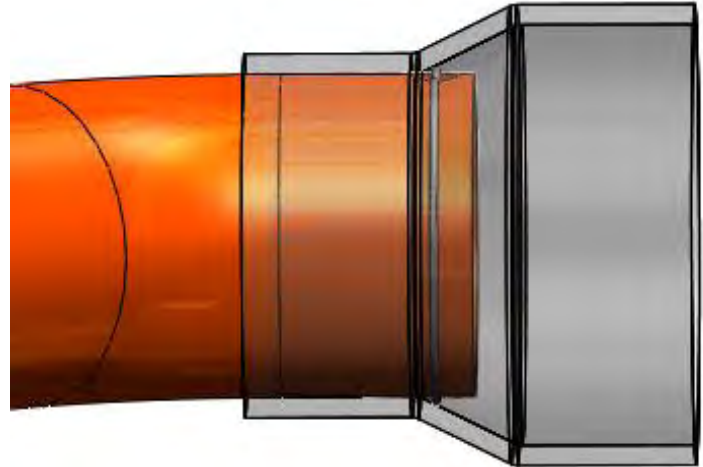

11. Once the boot and clamp are in place you can install the valve ensuring the flow orientation arrow on the side of the casting points towards the CAC. Then install the elbow boot with the supplied clamps. Leave all clamps loose until proper in vehicle fit can be determined.

Please note the flow orientation.



12. Install PAS tube assembly into the vehicle CAC side first. Note that you will need to rotate the tubes you achieve perfect alignment. Once you are happy with fit and the PAS unit will not contact any other components or vibrations. Tighten all spring clamps until the spring is spring bound.

13. Lay out supplied wiring harness over top of the engine.

Locate and connect the weather pack connector on the wiring harness to the solenoid on the PAS valve. See page 27 for more info.

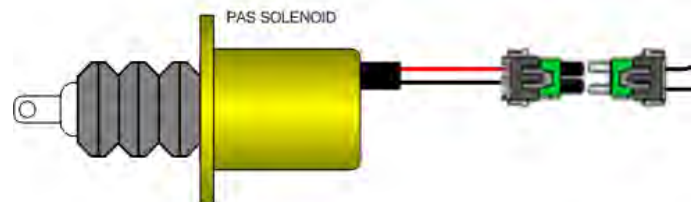

14. You will then need to route the switch wires through the firewall on the driver's side.

Choose a highly visible location for the switch and mount it to the dash.

NOTE: You may need to trim the switch wires to length once you have located where the switch is to be mounted.

Using a 1/8" drill, drill a pilot hole in the location you have selected for the switch to be mounted.

Finally using a 1/2" UNIBIT drill bit, drill an exact 1/2" round hole.

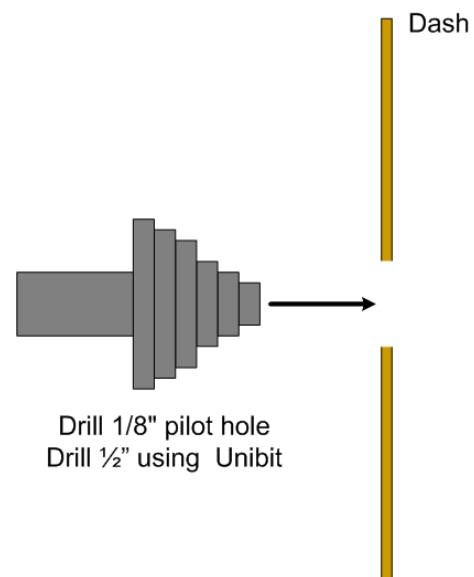

15. Once you have the mounting hole drilled, crimp the switch connectors to the switch wires and install the correct switch wires to the correct switch terminals, then insert the switch into the dash from the backside.

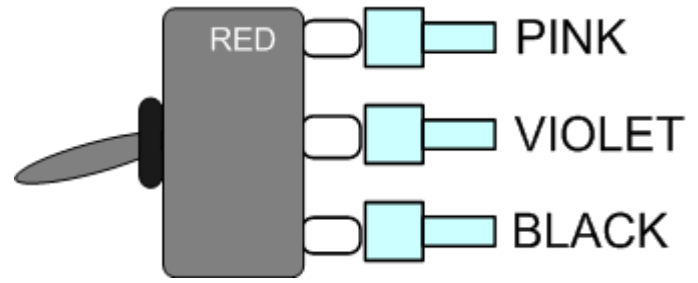

16. Mount the switch so that the groove on the thread boss is facing down.

Adjust the HEX washer/nut so that the switch threads do not protrude an unsightly amount.

Switch install with decal

Apply the supplied decal to the dash and tighten the round plastic nut.

Switch install with Guard

Install the switch guard onto the switch by aligning the tab with the groove on the thread boss.

Then tighten on the round plastic nut and apply the decal to the switch guard.

Switch install with Decal

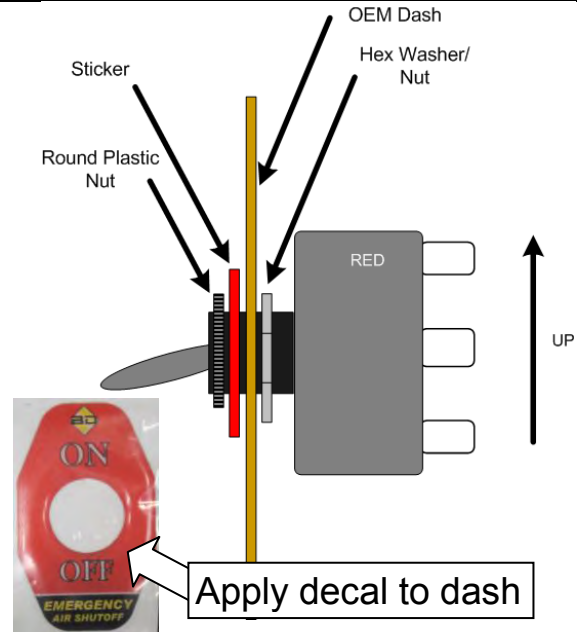

Switch Install with Guard

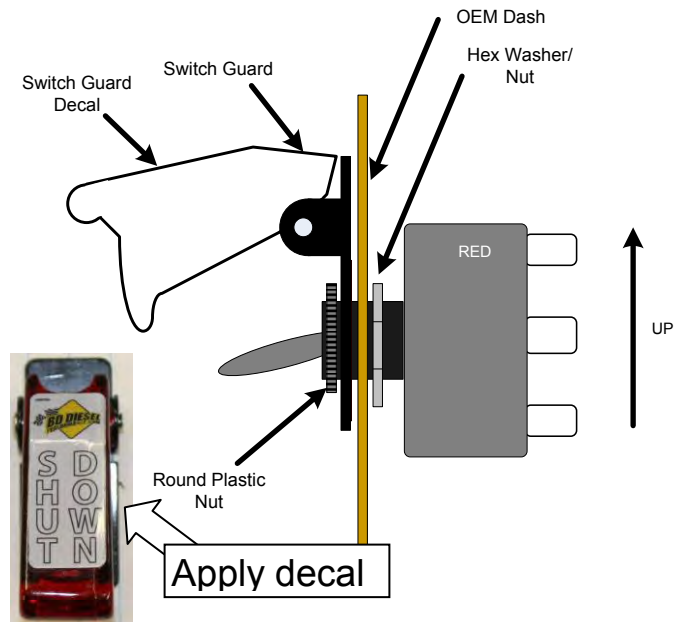

INSTALLATION without OVER SPEED ELECTRONICS

17. Next run the wire for the battery connection then trim and crimp the ring terminals and connect to the respective power and ground connections.

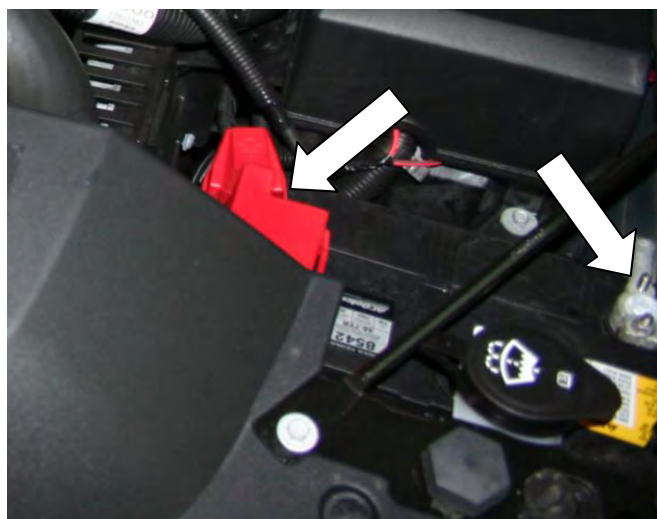

18. For the last connection you will need to locate ignition power.

Locate the battery junction box at the driver's side mid of the engine compartment.

Open the junction box and locate the appropriate fused ignition power circuit (see table below). Install fuse tapper on to fuse, reinstall fuse. Trim the pink wire to length and crimp the flag connector to the wire and connect the pink wire lead wire with flag connector to this new connection.

Route wire out of the box and close lid.

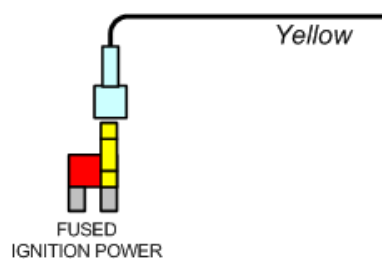

AUX HVAC-IGN #45 (10AMP)

Pin	Wire Color	Circuit No.	Function
39	RDO Fuse	15A	Digital Radio Receiver (U2K), Radio, Rear Seat Audio (RSA) Control (UK6), Chime Module (UL5)
40	MISC IGN Fuse	10A	Auxiliary Body Control Module (XBCM) (EXP), Stop Lamp Switch, Transfer Case Shift Control Module (NQF or NQH), Trailer Brake Control Module (JL1)
41	L/GATE RELSE Fuse	15A	Not Used
42	AIRBAG BATT Fuse	15A	Inflatable Restraint Passenger Presence System (PPS) Module, Inflatable Restraint Sensing and Diagnostic Module (SDM), Inflatable Restraint Vehicle Roll-over Sensor (ASF)
43	IPC Fuse	10A	Body Control Module (BCM), Instrument Panel Cluster (IPC)
44	EXP/PTO Fuse	15A	Auxiliary Body Control Module (XBCM) (EXP) Power Take Off Relay (PTO)
45	AUX HVAC-IGN Fuse	10A	Instrument Panel Cluster (IPC), Inside Rearview Mirror (ISRV), Heated Steering Wheel Module Control (KA9)
46	CHMSL Fuse	15A	Center High Mounted Stop Lamp (CHMSL)
47	REAR DEFOG Fuse	30A	Rear Window Defogger Grid

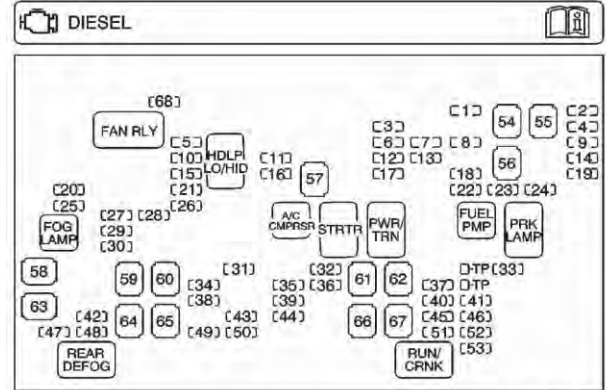

- | | | | |
|-------------------------------------|-----------------------|--|---------------------------|
| MINI FUSES
MINI-FUSIBLES | | J-CASE FUSES
FUSIBLES JCASE | |
| 1 - ESC/ALC EXH (30A) | 19 - ITBC (15A) | 38 - AMP (30A) | 54 - ALC/COMP (40A) |
| 2 - TRLR STOP LT (10A) | 20 - HDLP WASH (20A) | 39 - RDO (15A) | 55 - HEAVY DUTY ABS (60A) |
| 3 - ENG (15A) | 21 - REAR WASH (15A) | 40 - MISC IGN (10A) | 56 - ABS-1 (40A) |
| 4 - TRLR STOP RT (10A) | 22 - TRLR PRK (15A) | 41 - L/GATE RELSE (15A) | 57 - STRTR (40A) |
| 5 - FRT WASH (15A) | 23 - LT PRK (15A) | 42 - AIRBAG BATT (15A) | 58 - STUD-2 (30A) |
| 6 - FUEL HTR (15A) | 24 - RT PRK (15A) | 43 - IPC (10A) | 59 - LBEC1 (80A) |
| 7 - TCM-BATT (15A) | 25 - FOG LAMP (15A) | 44 - EXP/PTO (15A) | 60 - ELEC RUN BOARD (30A) |
| 8 - ABS 2 (25A) | 26 - HORN (15A) | 45 - AUX HVAC-IGN (10A) | 61 - WSW/HTR (60A) |
| 9 - TRLR BCK/UP (10A) | 27 - HI HDLP (15A) | 46 - CHMSL (15A) | 62 - TREC (30A) |
| 10 - LO HDLP-LT (20A) | 28 - DRL (15A) | 47 - REAR DEFOG (30A) | 63 - STUD-1 (40A) |
| 11 - ECM-BATT (10A) | 29 - HI HDLP-LT (10A) | 48 - HTD MIR (15A) | 64 - MBEC1 (60A) |
| 12 - DSL ECM (30A) | 30 - DRL 2 (15A) | 49 - SEO B1 (15A) | 65 - HVAC BLWR (40A) |
| 13 - TRNS IGN 1 (15A) | 31 - S/ROOF (30A) | 50 - LTR (20A) | 66 - LGM (30A) |
| 14 - VEH BCK/UP (10A) | 32 - DLIS (2A) | 51 - SEO/ALC (10A) | 67 - LBEC2 (60A) |
| 15 - LO HDLP-RT (20A) | 33 - WPR (25A) | 52 - HVAC-IGN (10A) | |
| 16 - A/C CMPRSR (10A) | 34 - SEO B2 (30A) | 53 - ECM-IGN (15A) | |
| 17 - EMC/THROT CONT (15A) | 35 - EAP (15A) | 54 - FAN (10A) | |
| 18 - FUEL PUMP (25A) | 36 - HVAC BATT (10A) | | |
| | 37 - AIRBAG IGN (10A) | | |

INSTALLATION without OVER SPEED ELECTRONICS

19. Double check all wiring connections and ensure wires are routed away from any heat sources and moving parts. Then install the loom with the supplied tee connector and clips for the loom ends and continue to the testing flow chart without over speed electronics in this manual.

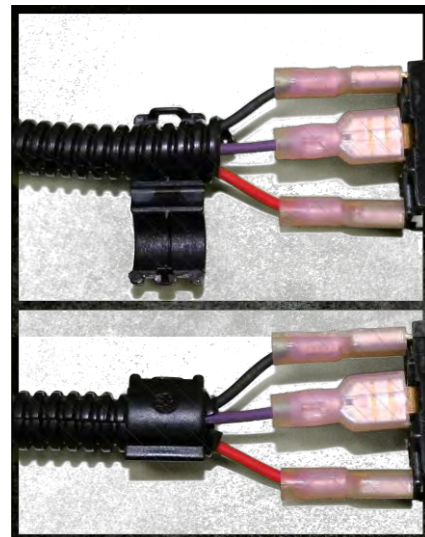
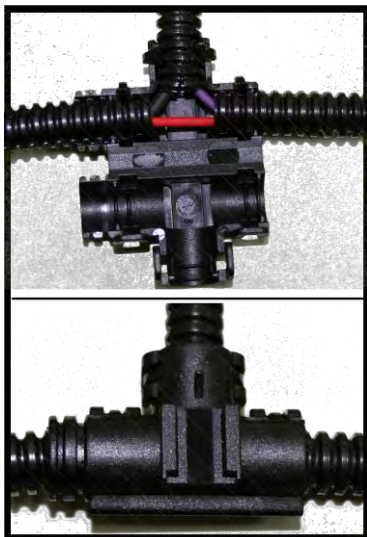

WIRING DIAGRAM with OVER SPEED ELECTRONICS (1036713)

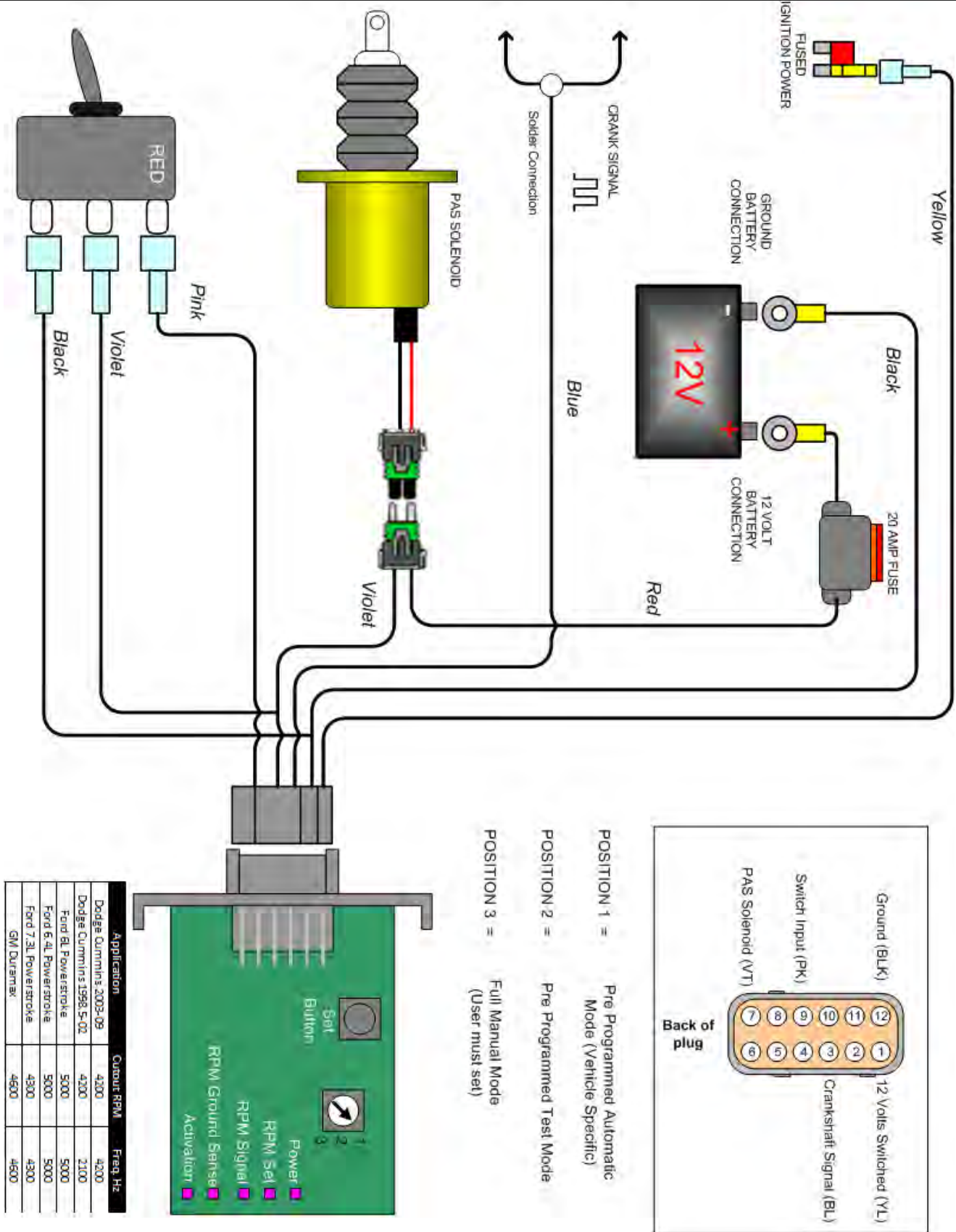

WIRING DIAGRAM without OVER SPEED ELECTRONICS (1036713-M)

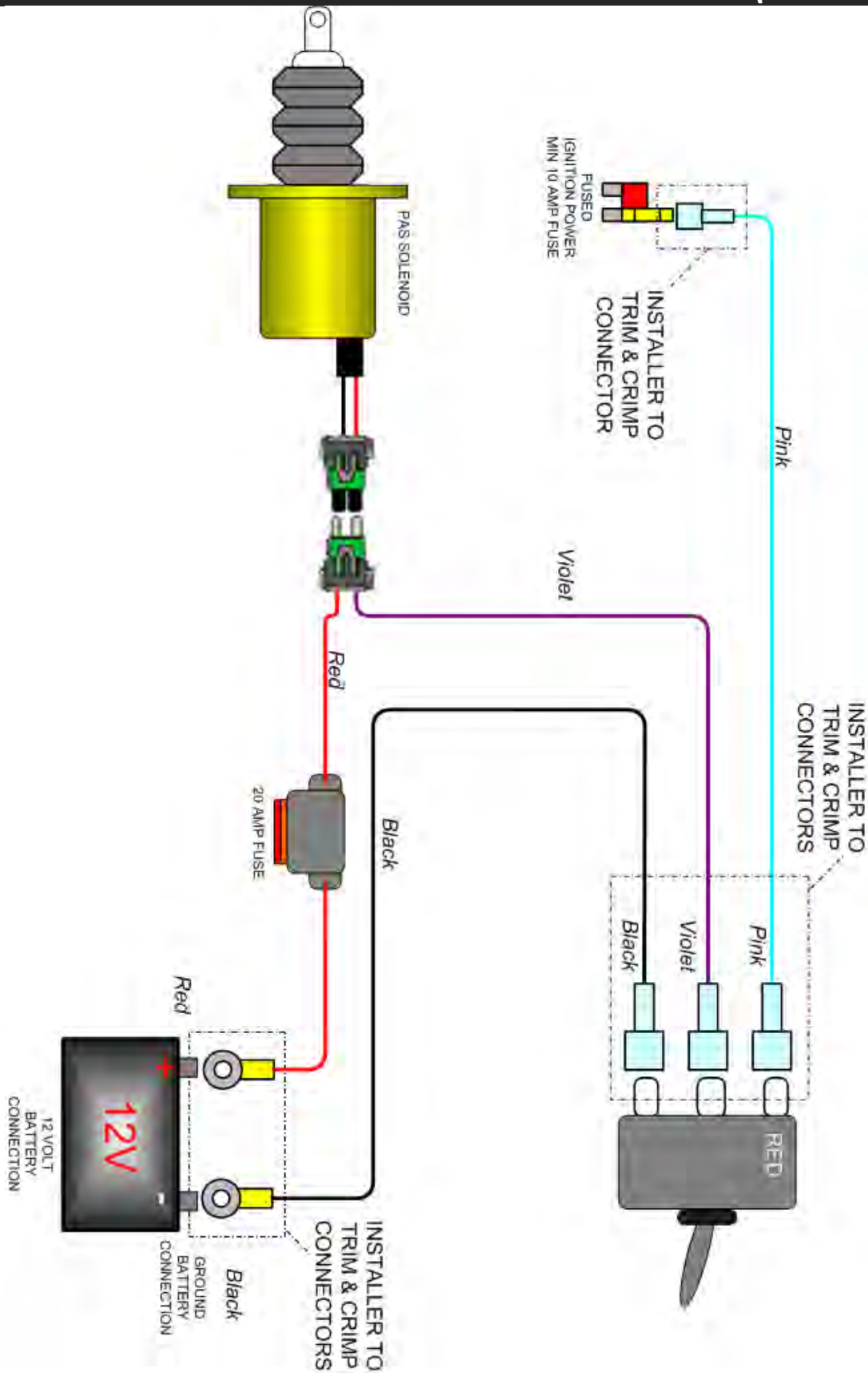

BEAD RING AND DRILL JIG INSTALLATION

- WRAP CORRECT STICKER AROUND PIPE. LINE UP STICK EDGE WITH EDGE OF PIPE. MAKE SURE STICKER IS SQUARE AROUND PIPE AND BOTH ENDS CONNECT
- CENTER PUNCH CENTER OF MARKED HOLES
- USE CORRECT SIZE DRILL BIT AND DRILL THROUGH PIPE. ROTATE PIPE AND DRILL THROUGH SECOND MARKED HOLE. THE HOLES SHOULD BE PERFECTLY STRAIGHT
- REMOVE STICKER AND DEBURR INSIDE AND OUT SIDE OF PIPE
- THEN WRAP WIRE BEAD AROUND TUBE. YOU MAY NEED TO FORM IT SLIGHTLY. IF DONE CORRECTLY THE BEAD WILL NOT PULL OFF OF TUBE
- INSTALL SILICONE BOOT AND CLAMP AS YOU WOULD NORMALLY

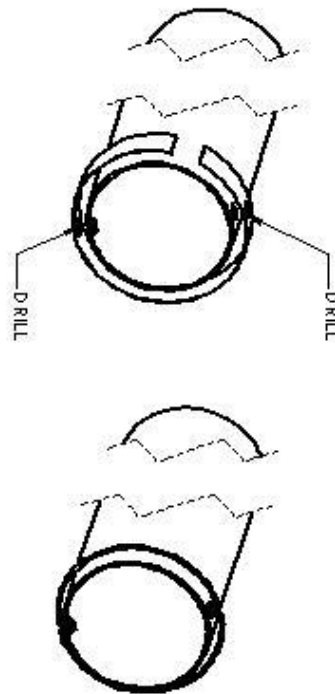
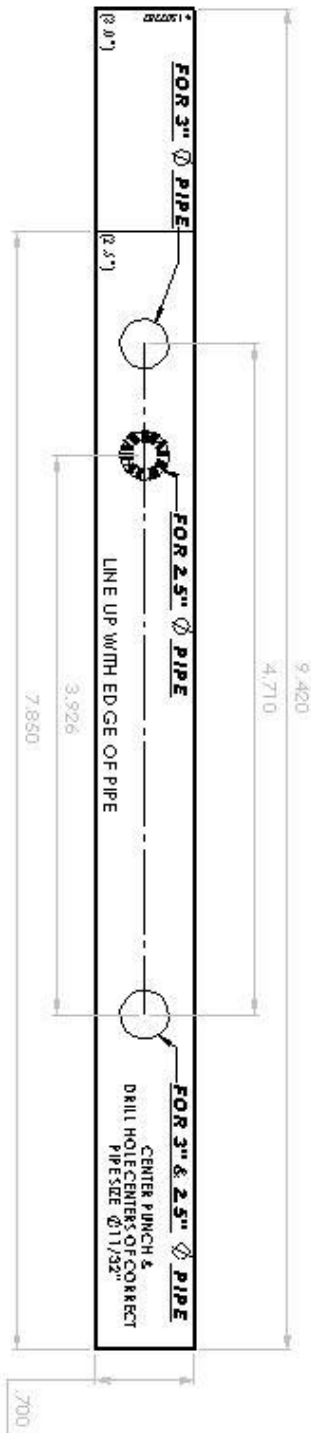

RESETTING THE VALVE

Valve Activated (Closed)

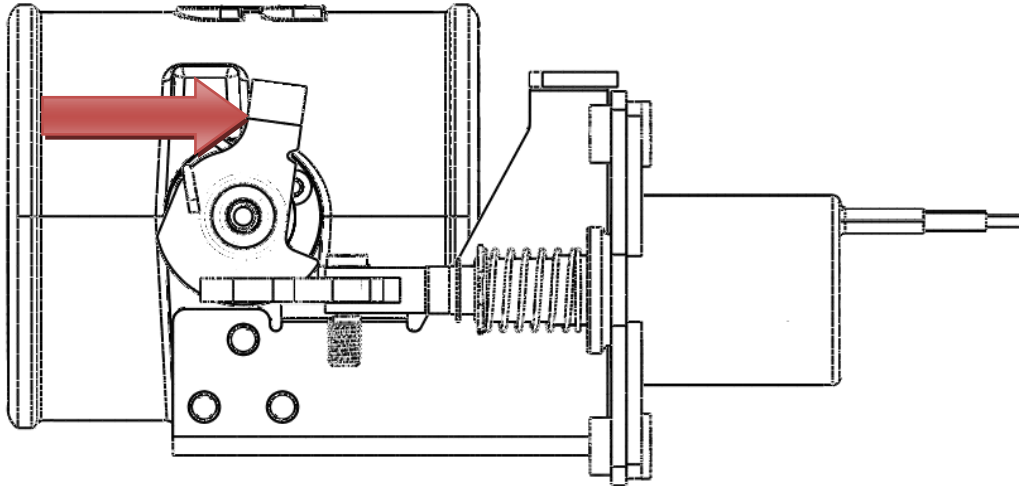

Valve Reset (Open)

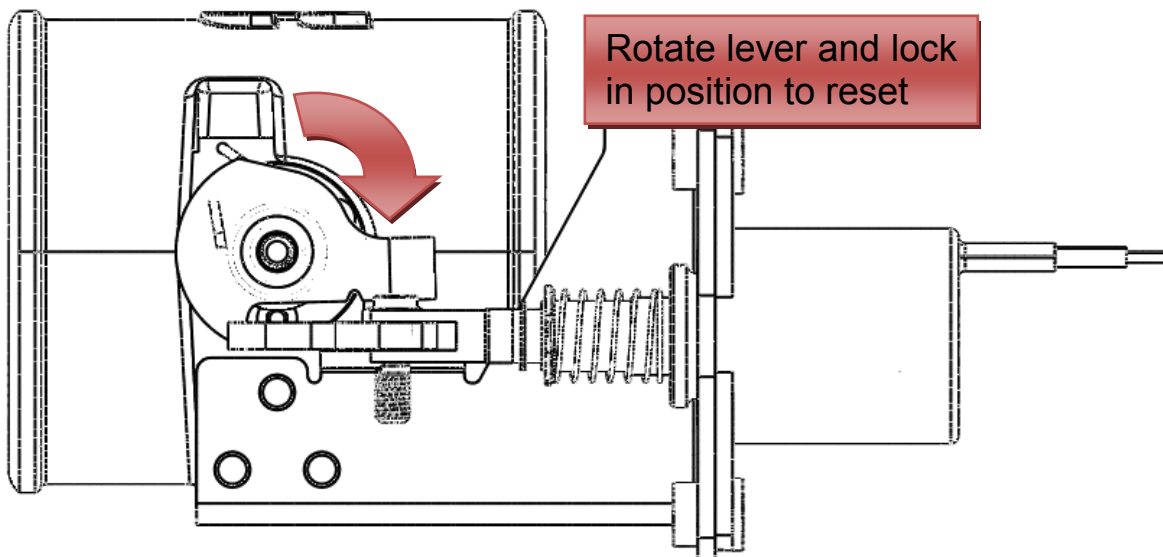

SETUP, TESTING AND VERIFICATION with OVER SPEED ELECTRONICS

Each unit is specifically configured for each model of truck. As in the case of different model years and makes the engine RPM frequency is different.	Engine Idle Speed Frequency
	2011
	600-800 Hz (1:1) ratio

2011 Duramax (LML)	Activation RPM	Activation Freq. (Hz)
PAS Switch Position #1 (Automatic Mode)	4600	4600
PAS Switch Position #2 (Test Mode)	1200	1200
PAS Switch Position #3 (Manual Mode)	User Configured	User Configured

Automatic Mode (Pre Configured RPM)	
Action	Failure/Fix/Notes
1. Turn the ignition key to the on position. You should see the RED light illuminate on the toggle switch.	If the LED does not illuminate, check the wiring to the back of the switch first. Then check entire circuit.
2. Next, start the engine. 3. With the engine idling, activate the toggle switch. You should hear the solenoid activate and the valve close. The engine should die. Once the engine dies the switch should flicker ON and OFF indicating a trip condition.	If the engine does not die, check to make sure the valve actuated. If the valve did not actuate check switch and ground wiring. If valve did actuate but the engine is still running, ensure nothing has contacted the valve mechanism
4. You can now reset the valve, by rotating the upper lever and engaging the solenoid stop.	

BD Engine Brake Inc.

Plant Address: 33541 MacLure Rd. Abbotsford, BC, Canada V2S 7W2

U.S. Shipping Address: 88-446 Harrison St, Sumas, WA 98295 U.S. Mailing Address: P.O. Box 231, Sumas, WA 98295

Phone: 604-853-6096 | Fax: 604-853-8749 | Internet: www.bd-power.com

5. With the valve reset, remove the outer enclosure from the control module. There are two locking tabs on the sides of the enclosure.

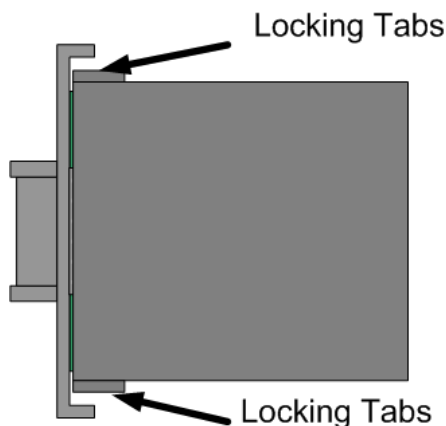

6. Change the position selection switch to position #2 (Auto Test). Slide enclosure cover over circuit board.

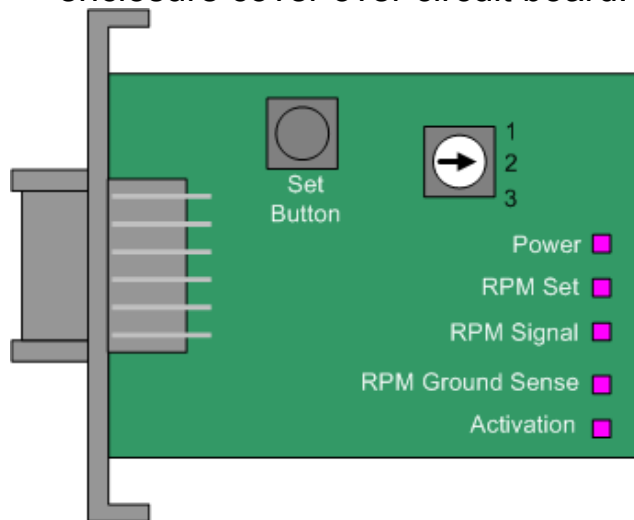

7. Start the vehicle, with the vehicle in park step on the throttle increasing the engine RPM. At 1200RPM the PAS should engage itself automatically, and the engine should stall. Like with all activations the toggle switch should flash.

If the engine did not stall, check to make sure the valve actuated.
If the valve did not actuated, double check the engine RPM electrical connection.
Check the RPM Signal LED on the circuit board, it should flash proportionally to the engine RPM.

8. Reset the valve and reset the mode position switch to position #1

You are now complete and the unit should function correctly. This test cycle should be completed once a year.

Manual Mode (User Configured RPM)

Setup

With the control unit, the user/installer has the ability to set their own activation RPM. It is necessary that you chose a low activation RPM first to test that the units is operating correctly. Once it is, you will need to set the high limit RPM activation.

Note: When you press the Set button the module will add 25% to the set speed.

1. Open electronic enclosure, by releasing the two locking tabs on the side of the unit.

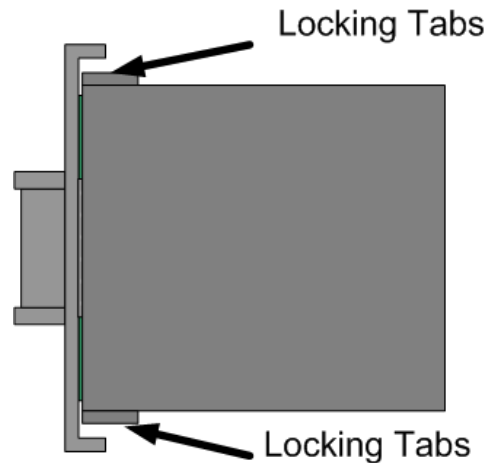

2. Adjust the position switch to position #3.

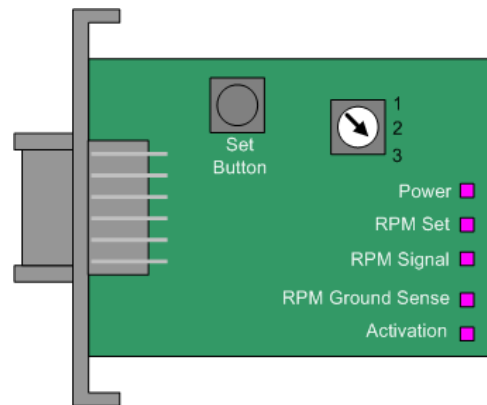
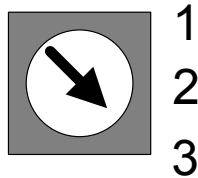

3. Start the engine.

4. Press and hold the RPM SET button.

When you push the SET RPM button will see the “RPM Set” LED illuminate.

5. With another person helping you, have them step on the accelerator with the vehicle in park. Raise the engine RPM to 1200 RPM.

6. Release the SET RPM button.

Upon releasing the button the unit will store the RPM + 25%. So for this example the unit has stored 1200RPM + 25% = 1500RPM.

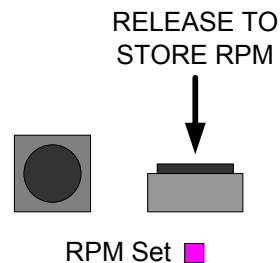
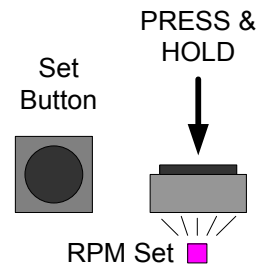

You should see the RPM signal flash proportionally to engine RPM.

7. Now increase the RPM of the engine to test the activation circuit is working correctly. As in this example the valve should activate at 1500RPM.

You should see the ACTIVATION LED flash ON/OFF on activation.

If the valve does not activate check the wiring.

If the valve activates but the engine does not stall, ensure nothing has contacted the valve linkage.

8. With the valve activated the engine should die. Reset the valve and restart the engine.

9. Press and hold the RPM SET button.

When you push the SET RPM button will see the “RPM Set” LED illuminate.

10. With another person helping you, have

BD Engine Brake Inc.

Plant Address: 33541 MacLure Rd. Abbotsford, BC, Canada V2S 7W2

U.S. Shipping Address: 88-446 Harrison St, Sumas, WA 98295 U.S. Mailing Address: P.O. Box 231, Sumas, WA 98295

Phone: 604-853-6096 | Fax: 604-853-8749 | Internet: www.bd-power.com

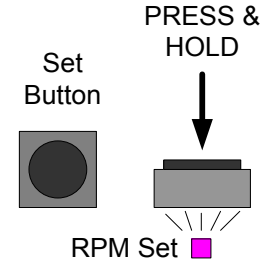
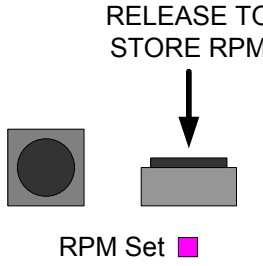
<p>them step on the accelerator with the vehicle in park. Raise the engine RPM to MAXIMUM engine RPM.</p> <p>11. Release the SET RPM button.</p> <p>Upon releasing the button the unit will store the RPM + 25%. So for this example the unit has stored MAXIMUM engine RPM + 25%.</p>	 
<p>12. You can now put the electronic enclosure back together and secure it the fuse box.</p>	
<p>13. With the engine running you will need to test to make sure the manual activation switch is functioning correctly.</p> <p>14. With the engine running, lift the activation switch and the engine should die.</p> <p>15. Reset the valve and you are now complete.</p>	<p>If valve does not activate check the wiring.</p> <p>If the valve activates and the engine does not die ensure nothing has contacted the linkage.</p>
<p>You have now completed the installation, please be sure to complete the test once a year to make sure the unit is functioning correctly.</p>	

TESTING FLOW CHART with OVER SPEED ELECTRONICS

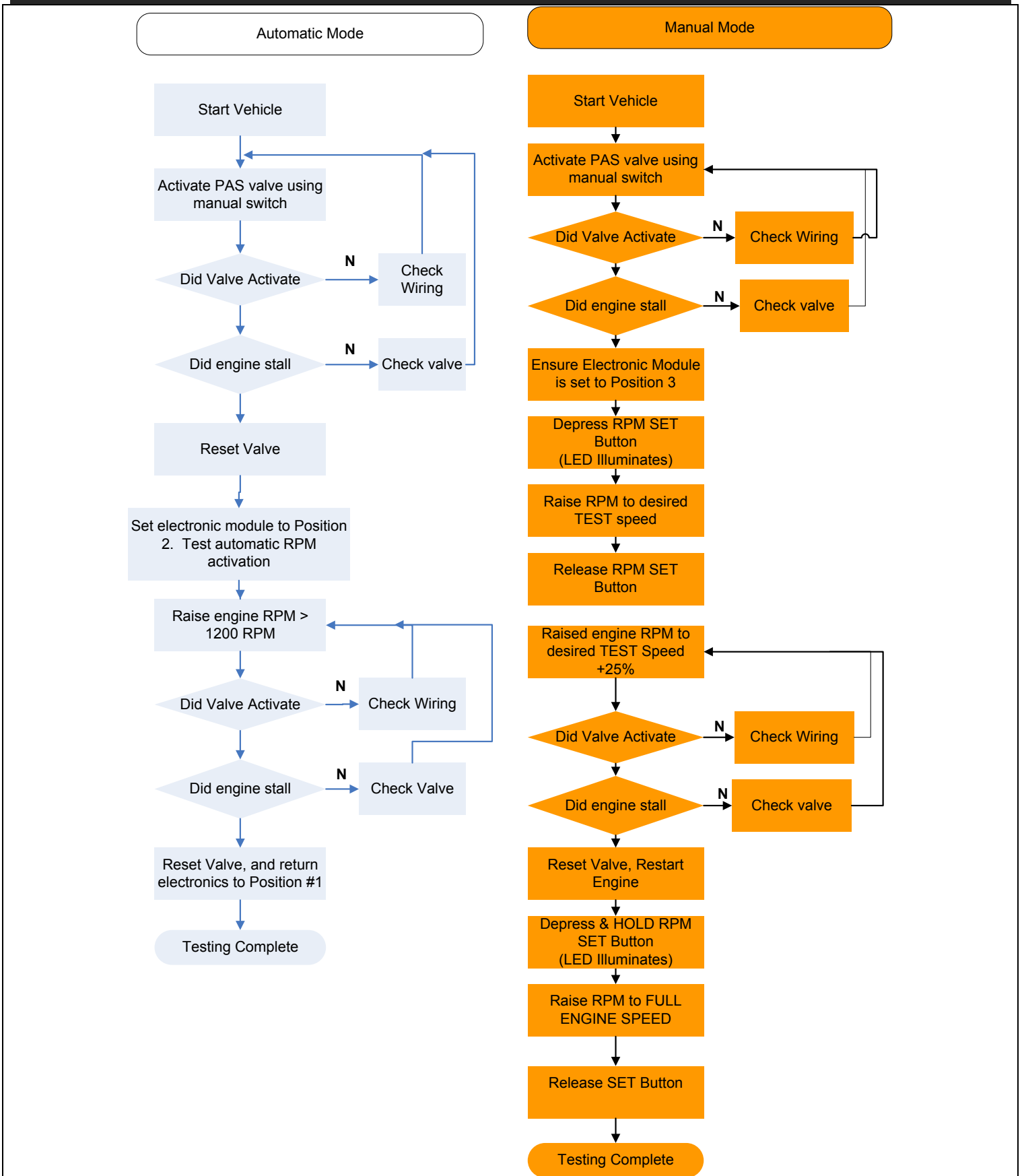

TESTING FLOW CHART *without OVER SPEED ELECTRONICS*

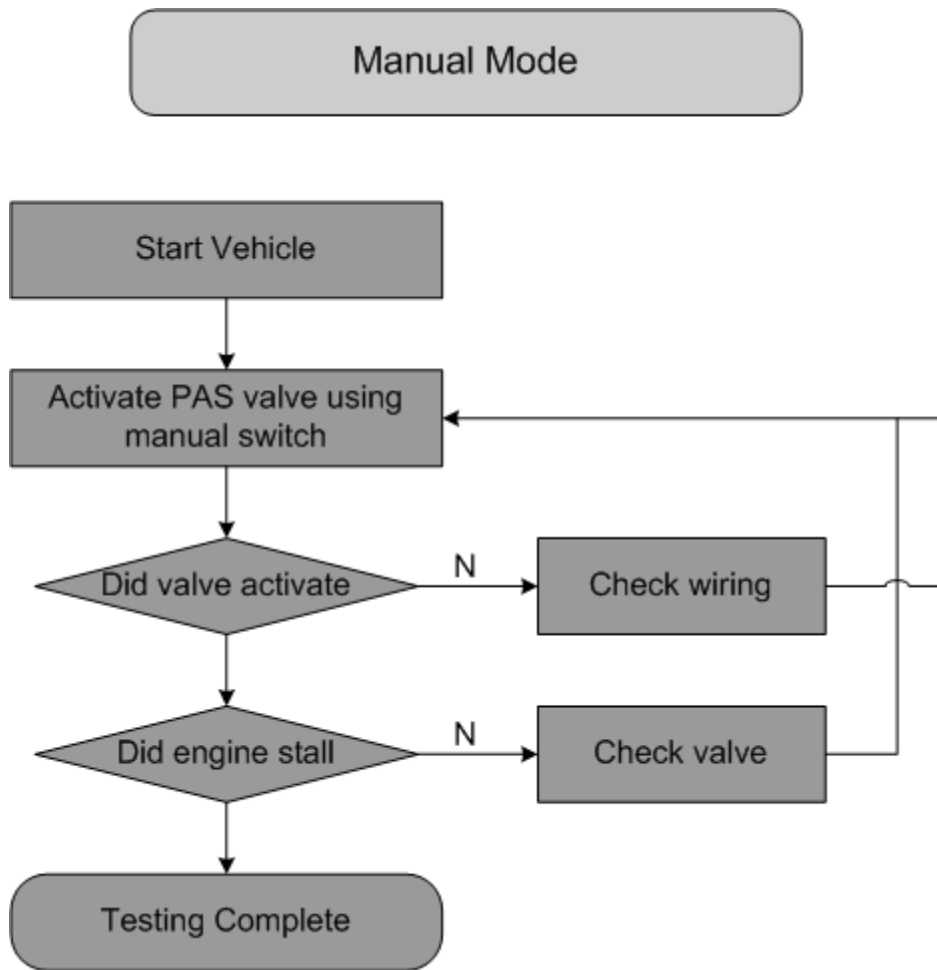

LED OPERATION

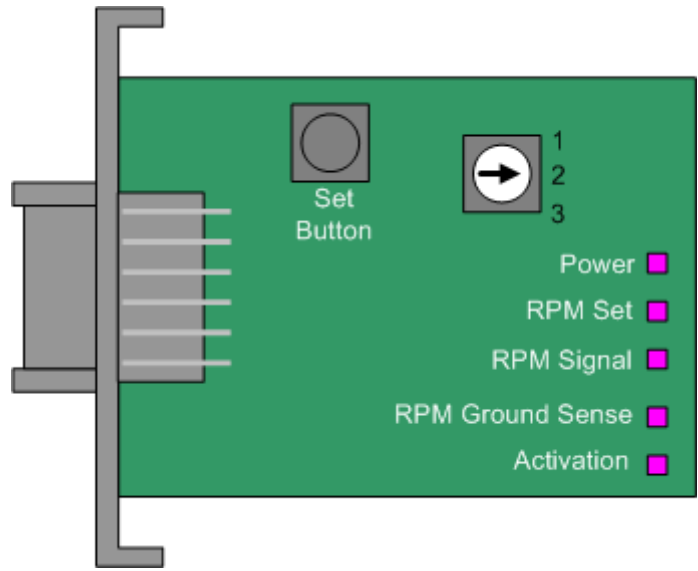

LED	Description
POWER	Illuminates when unit is POWERED
RPM SET	Illuminates when SET Button is Pressed
RPM Signal	Flashes proportional to Engine RPM
Ground Sense	Illuminates when a GROUND signal is sensed on the activation line
Activation	Flashes when a valve activation is commanded manually (switch) or automatically
Toggle Switch LED	The LED will flash indicating either a problem with the system (Loss of RPM or Power) or an activated valve activation.



Visit our Internet forums at <http://www.dieselperformance.com> and share your comments or technical support questions with some of the industry's leading experts in the diesel field.

If you have any technical difficulties, concerns, comments, or complaints, please phone our Technical Support hotline at (800) 887-5030 between 8:30am-5:00pm PST (Pacific Standard Time) Monday to Friday, or post a message on the BD Discussion Forums located at:

<http://forum.bd-power.com/>