

C.A.C. Installation

For 6.0L

-- Installation Instructions --

6.0L	1042710
------	---------



PLEASE READ ALL INSTRUCTIONS BEFORE INSTALLATION

Tools Required

		
Sockets 8,10,11,13mm & 1/2"	Air Wrench	Clip Remover

Kit Contents

1402700	1407003	1405211
		
<i>Charge Air Cooler</i> Qty: 1	<i>Straight Ribbed Boot</i> Qty: 1	<i>3.25" Clamps</i> Qty: 4

1407030	1407008	1401579P
		
<i>3.50" Clamps</i> Qty: 2	<i>Step Ribbed Boot</i> Qty: 2	<i>Powder Coated Intake Pipe</i> Qty: 1

Procedure

1. Remove the air intake box by loosening the gear clamp (8mm head) and unplugging the Mass Air Flow sensor and filter minder.

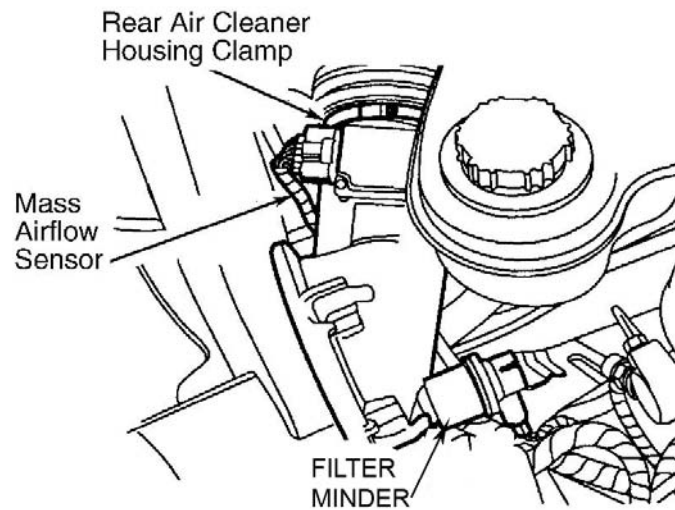

2. Next loosen the boot clamps(11mm head) and remove the stock Charge Air Cooler tubes

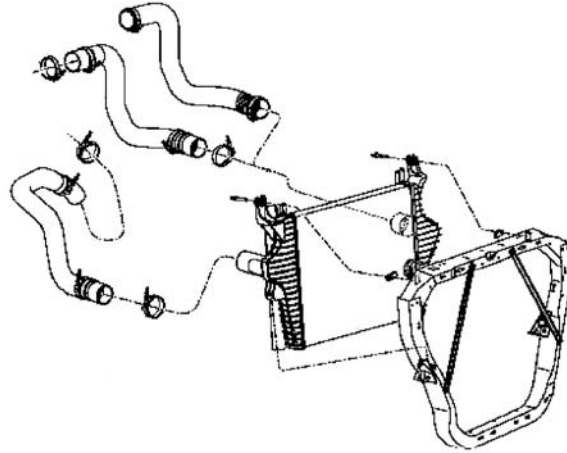

3. Disassemble the rubber radiator shielding by popping out the push pins.

IMPORTANT: Ensure the positive battery cable is out of the way.

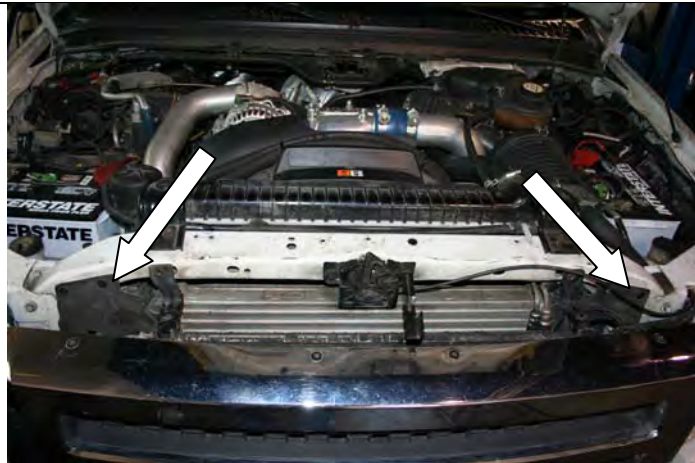

BD Engine Brake, Inc.

Plant Address: Unit A10, 33733 King Rd, Abbotsford, BC, Canada V2S 7M9

U.S. Shipping Address: 88-446 Harrison St, Sumas, WA 98295 U.S. Mailing Address: P.O. Box 231, Sumas, WA 98295

Phone: 604-853-6096 Fax: 604-853-8749 Internet: www.bd-power.com

4. Mark the hood latch position with a felt or paint pen.



5. After you have marked the hood latch you can now remove the top radiator mount brackets, A/C condenser brackets and hood latch.



6. Locate and remove the C.A.C. bolts for the top radiator support. (10mm head)

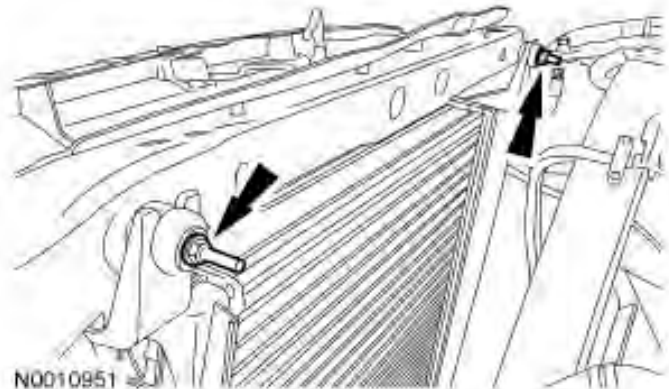

7. Lift out the top radiator support by removing 8 (13mm head) ensuring all mounting hardware has been removed.

NOTE: The radiator support may be removed easier by lifting up and out at one end.



8. Move A/C condenser and lines to the passenger side to gain clearance to remove the C.A.C.



9. Switch over the top and side rubber mounting isolators from the old cooler to the BD Charge Air Cooler (1402700).



10. When positioning the new Charge Air Cooler into position move the A/C condenser and lines to the passenger side to gain clearance while seating the side isolators firmly in place.



BD Engine Brake, Inc.

Plant Address: Unit A10, 33733 King Rd, Abbotsford, BC, Canada V2S 7M9

U.S. Shipping Address: 88-446 Harrison St, Sumas, WA 98295 U.S. Mailing Address: P.O. Box 231, Sumas, WA 98295

Phone: 604-853-6096 Fax: 604-853-8749 Internet: www.bd-power.com

11. Reinstall the top radiator support and continue to reconnect the C.A.C. mounting bolts, top radiator mounting brackets, A/C condenser brackets and hood latch.



12. Mount the (1407008) 3-3 1/4" step ribbed boots on the BD intercooler and tighten the (1407030) 3 1/2" clamps until the spring is bound. (1/2" head)

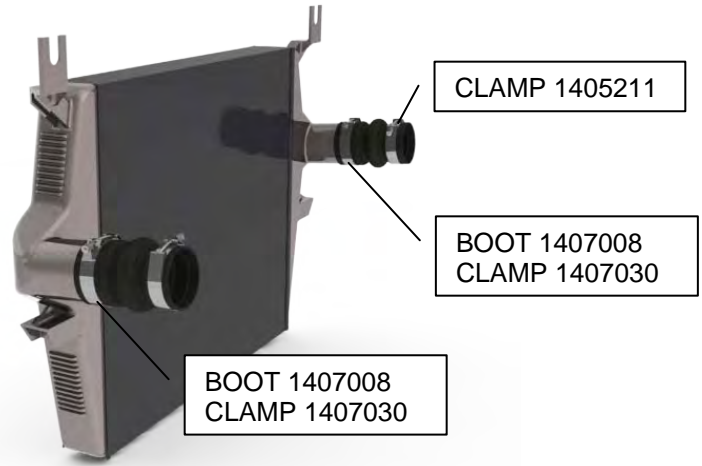

2003-2004	2005-2007
-----------	-----------

13. If the truck is a **03/04 model** the existing driver's side stock steel pipe and intake boot are used to connect to the supplied intercooler boot.

NOTE: The BD steel pipe and intake boot are not needed for this application.

14. If the truck is a **05-07 model** the supplied BD steel pipe (1401579P) and BD boot (1407003) are used, eliminating the driver's side stock plastic pipe.

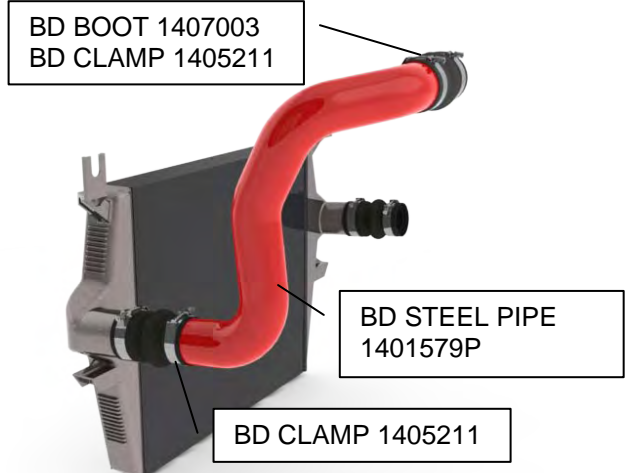
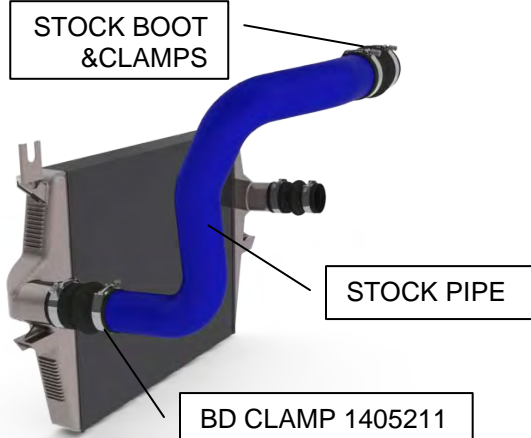

15. Reconnect the passenger side C.A.C. tube with the stock clamp and the supplied BD clamp (1405211) and tighten until the spring is bound. Also reconnect the air intake and all sensors.

Reinstall the battery cables (positive lead first then the negative lead) and the rubber cover to complete the installation.



BOOT CONNECTIONS

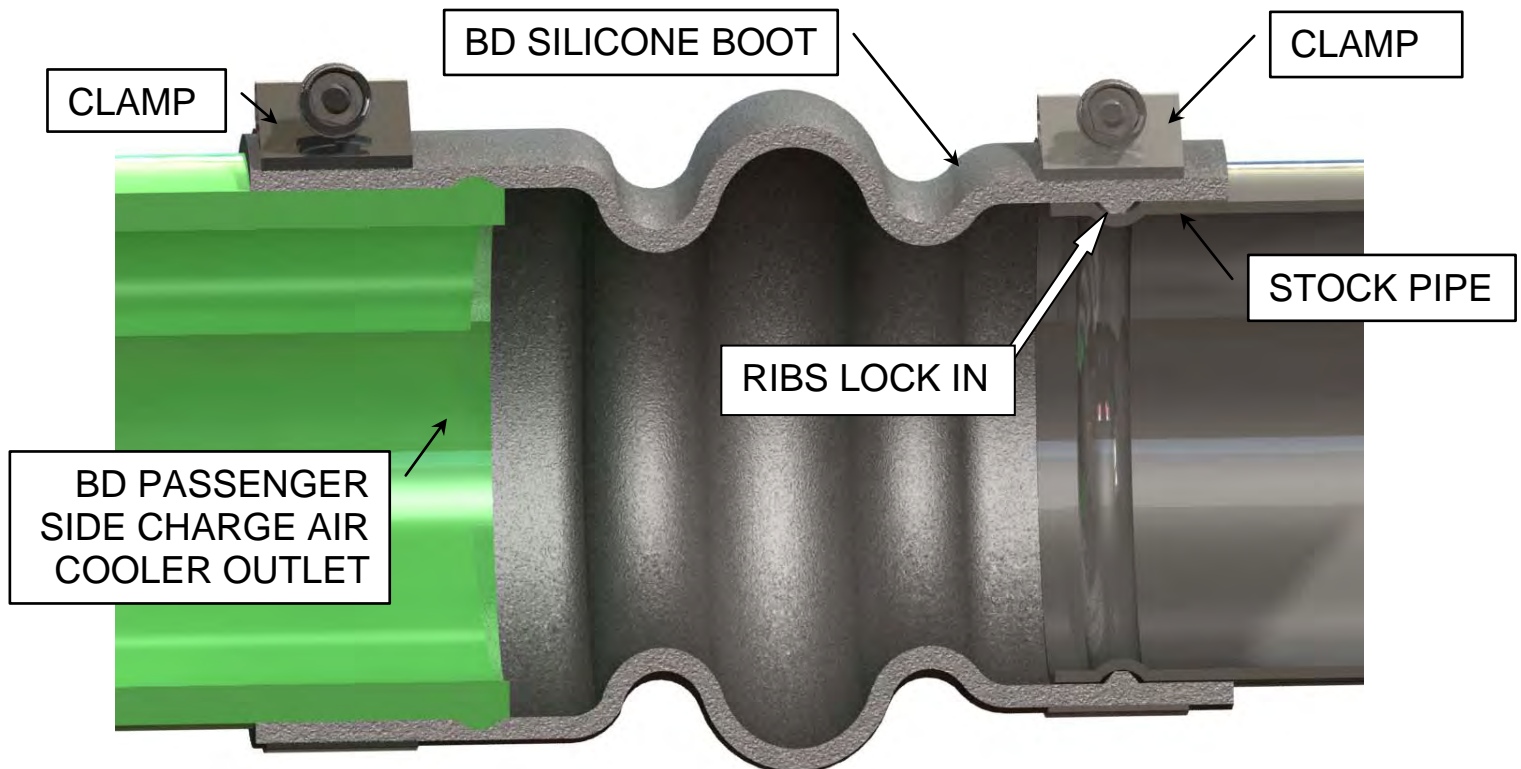

BD Engine Brake, Inc.

Plant Address: Unit A10, 33733 King Rd, Abbotsford, BC, Canada V2S 7M9

U.S. Shipping Address: 88-446 Harrison St, Sumas, WA 98295 U.S. Mailing Address: P.O. Box 231, Sumas, WA 98295

Phone: 604-853-6096 Fax: 604-853-8749 Internet: www.bd-power.com