



## **BD 6.7L Super "B" Special Turbo Kit**

For 2007.5 - 2012 6.7L Dodge

### **-- Installation Instructions --**

PN# 1045140

**PLEASE READ ALL INSTRUCTIONS BEFORE INSTALLATION**

**UNLESS AN EO# IS LISTED, THIS PRODUCT IS LEGAL IN CALIFORNIA FOR RACING VEHICLES ONLY, WHICH MAY NEVER BE USED UPON A HIGHWAY.**

**AFTERMARKET TUNER OR PROGRAMMER WILL BE REQUIRED TO USE THIS TURBOCHARGER KIT.**

BD Engine Brake Inc.

Plant Address: 33541 MacLure Rd. Abbotsford, BC, Canada V2S 7W2

U.S. Shipping Address: 88-446 Harrison St, Sumas, WA 98295 U.S. Mailing Address: P.O. Box 231, Sumas, WA 98295

Phone: 604-853-6096 | Fax: 604-853-8749 | Internet: [www.bd-power.com](http://www.bd-power.com)

# Kit Contents

<p style="text-align: center;"><b>1405133</b></p> 	<p style="text-align: center;"><b>1045987</b></p> 	<p style="text-align: center;"><b>1090012</b></p> 
<p style="text-align: center;"><i>Super "B" Special 6.7L Turbo</i></p>	<p style="text-align: center;"><i>Exhaust Manifold Kit</i></p>	<p style="text-align: center;"><i>EGB Kit</i></p>
<p style="text-align: center;"><b>Qty: 1</b></p>	<p style="text-align: center;"><b>Qty: 1</b></p>	<p style="text-align: center;"><b>Qty: 1</b></p>
<p style="text-align: center;"><b>1453255</b></p>	<p style="text-align: center;"><b>1100740</b></p>	<p style="text-align: center;"><b>1045986</b></p>
		
<p style="text-align: center;"><i>Down Pipe</i></p>	<p style="text-align: center;"><i>4" Stainless Steel Down Pipe Clamp</i></p>	<p style="text-align: center;"><i>Exhaust Manifold Gasket Set</i></p>
<p style="text-align: center;"><b>Qty: 1</b></p>	<p style="text-align: center;"><b>Qty: 1</b></p>	<p style="text-align: center;"><b>Qty: 1</b></p>

BD Engine Brake Inc.

Plant Address: 33541 MacLure Rd. Abbotsford, BC, Canada V2S 7W2

U.S. Shipping Address: 88-446 Harrison St, Sumas, WA 98295 U.S. Mailing Address: P.O. Box 231, Sumas, WA 98295

Phone: 604-853-6096 | Fax: 604-853-8749 | Internet: www.bd-power.com

6.7L Turbo Hardware Kit (BD# 1405178)					
<b>1452811</b>	<b>1452814</b>	<b>1452815</b>	<b>1452812</b>	<b>1452822</b>	<b>1405926</b>
					
Bolt – M10 x 1.5 x 20mm	3/8”NF Nut	3/8” Washer	Bolt - M10 x 1.5 x 30mm	Bolt -3/8”NF x 1 1/2”	Downpipe V-Band Clamp
<b>Qty: 1</b>	<b>Qty: 2</b>	<b>Qty: 6</b>	<b>Qty: 1</b>	<b>Qty: 2</b>	<b>Qty: 1</b>
<b>1600035</b>	<b>1453123</b>		<b>1453113</b>	<b>1452821</b>	<b>1400113</b>
					
Sleeve	Drain Block Adapter		1 ¼” Clamp	1” Clamp	Insulated Clamp
<b>Qty: 2</b>	<b>Qty: 1</b>		<b>Qty: 3</b>	<b>Qty: 1</b>	<b>Qty: 1</b>
<b>1453924</b>	<b>1453925</b>	<b>1453926</b>	<b>1900037</b>	<b>1401578</b>	<b>1130058</b>
					
Hose Mender	7/8” Plug	Bracket	M6 Bolt	M6 Washer	M6 Nut
<b>Qty: 1</b>	<b>Qty: 1</b>	<b>Qty: 1</b>	<b>Qty: 1</b>	<b>Qty: 1</b>	<b>Qty: 1</b>

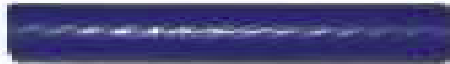
<b>1900002</b>

<b>3/4” Silicone Hose</b>
<b>Qty: 26”</b>

## ***Tools Required***

- Sockets : 8,10,13,14,15,17,19mm
- Wrenches: 8,10,13,14,15,17,19,21mm & 7/8"
- Pick Tool
- Pliers
- Torque Wrench

## ***Upgrade Options***

### **Description**

68 RFE BD Transmission  
 68 RFE Torque Converter  
 BD High Flow Injectors  
 Flowmax Lift Pump  
 07-09 Intercooler  
 BD Cool Down Timer  
 Cool air Intake  
 SS Exhaust System  
 68 RFE Pressure Loc  
 Intercooler Replacement Pipe

### **Part #**

Call for Application  
 Call for Application  
 Call for Application  
 1050310B  
 1042525  
 1081160  
 VOL16867  
 Call for Application  
 1030368  
 1042595

*If you are installing a BD Engine Brake with this turbo you will require:*

*(1) Turbo Plate PN# 1453238*

*(5) M8-1.25 x 20mm bolts*

*Reuse the existing (5) hardened M8 washers.*

## ***Pre-Installation Notes***

This turbocharger works best for 6.7L that operate up to 3000 RPM with fueling designed for 500 H.P. & less to keep exhaust temp within operating temperatures of 1200-1400°F.

Installation should occur on a cold vehicle, as turbo and exhaust components become very hot with use.

The BD Super B special system is recommended for trucks with 400-500 RWHP with a maximum efficient boost pressure of 45psi. For optimum performance, the turbo should operate between 37–45psi.

BD Engine Brake Inc.

Plant Address: 33541 MacLure Rd. Abbotsford, BC, Canada V2S 7W2

U.S. Shipping Address: 88-446 Harrison St, Sumas, WA 98295 U.S. Mailing Address: P.O. Box 231, Sumas, WA 98295

Phone: 604-853-6096 | Fax: 604-853-8749 | Internet: www.bd-power.com



## Procedure

Block wheels to ensure vehicle does not roll during installation. Record radio settings and disconnect the negative terminals on both batteries. Drain coolant from vehicle  
**\*CAUTION\*** coolant may be hot, use of protective gear is recommended.

1. With vehicle securely on a hoist, remove passenger side front wheel (7/8" or 15/16" socket) and inner fender (8mm socket).



2. Lift vehicle and support transmission using a jack. Then remove the cross member. By removing 3 (15mm) nuts at transmission mount and 4(18/21mm) bolts and nuts for cross member.

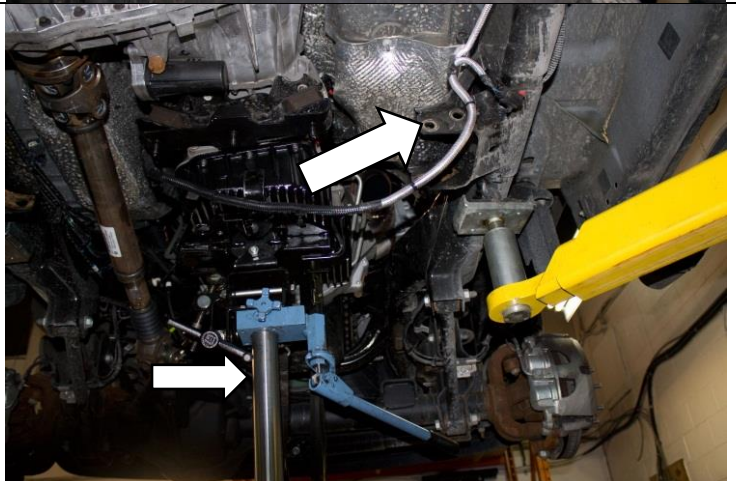

3. Disconnect downpipe at lower joint by transfer case.



BD Engine Brake Inc.

Plant Address: 33541 MacLure Rd. Abbotsford, BC, Canada V2S 7W2

U.S. Shipping Address: 88-446 Harrison St, Sumas, WA 98295 U.S. Mailing Address: P.O. Box 231, Sumas, WA 98295

Phone: 604-853-6096 | Fax: 604-853-8749 | Internet: www.bd-power.com

4. Disconnect downpipe at turbo connection (11mm) to remove downpipe.

5. Reinstall cross member ensuring the transmission remains supported then remove jack.

NOTE: Do not fully tighten bolts on cross member as the cross member will need to be removed in alater step.



6. Remove the 2 oil drain bolts (10mm) to extract drain pipe. Pull pipe out of engine block. Cover and temporary plug hole.

Lower vehicle to ground.



7. Disconnect intake sensors and remove the intake pipe (8mm socket & pliers) and air box (13mm).



BD Engine Brake Inc.

Plant Address: 33541 MacLure Rd. Abbotsford, BC, Canada V2S 7W2

U.S. Shipping Address: 88-446 Harrison St, Sumas, WA 98295 U.S. Mailing Address: P.O. Box 231, Sumas, WA 98295

Phone: 604-853-6096 | Fax: 604-853-8749 | Internet: www.bd-power.com



8. Disconnect VGT & speed sensor then remove passenger side CAC pipe.



9. Remove coolant lines that connect to the turbo, block and heater pipe.(7/8")
10. Remove oil feed line (21mm)



11. Remove 4 turbo to manifold 15mm nuts.
12. Lower turbo from manifold & remove



13. Pull out the oil dipstick to remove top engine cover (4 x 8mm bolts). Once cover is removed reinsert the oil dip stick.



14. Disconnect EGR temp sensor if equipped. (2011-2012 only)

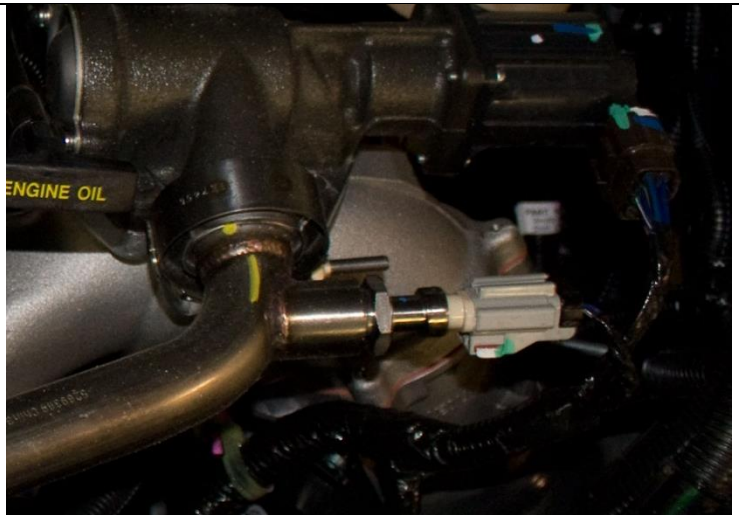

15. Detach EGR cross over tube, one support bolt (8mm) & two V-band clamps to remove the tube(11mm)





16. Remove lower heat shield, two (8mm) bolts & one (10mm) nut. Slide toward front of engine to remove.

17. Unbolt EGR bypass valve bracket, five bolts (10mm) and remove.

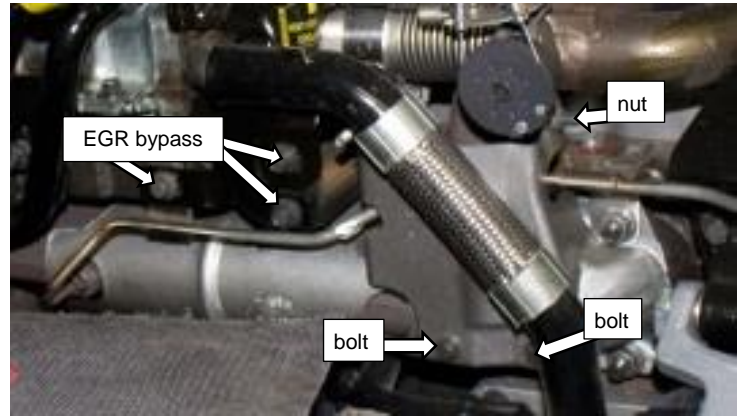

18. Loosen v-band clamp (11mm) at EGR bypass valve to EGR cooler. Then remove the two nuts holding mixer to the exhaust manifold.

Remove bypass valve & actuator then the lower heat shield.

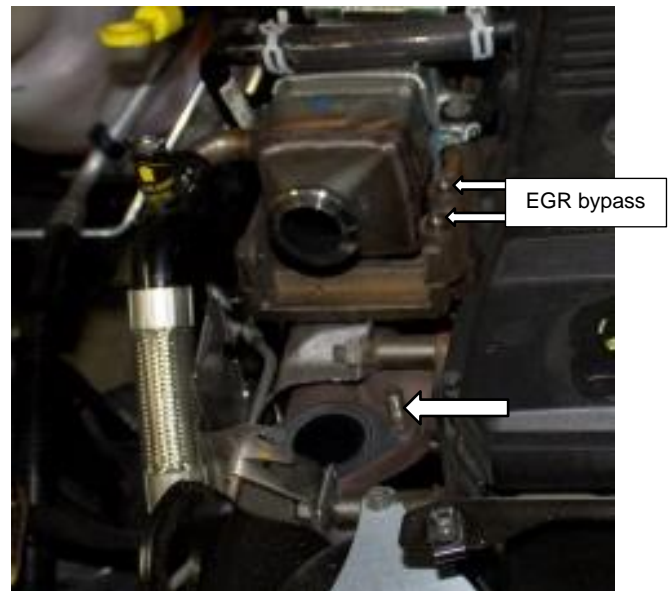

19. Disconnect PVC hose & remove hose/pipe assembly. (10 mm bolt)
20. Remove transmission dipstick tube, loosen (10mm) nut to remove tube off of stud.
21. Remove 10mm bolt holding coolant pipe bracket to EGR cooler then remove pipe.



22. Extract one (15mm) nut holding the exhaust pressure tube, then loosen manifold & sensor port to remove tube. (12mm)

NOTE: The sensor port is to be left open to atmosphere.

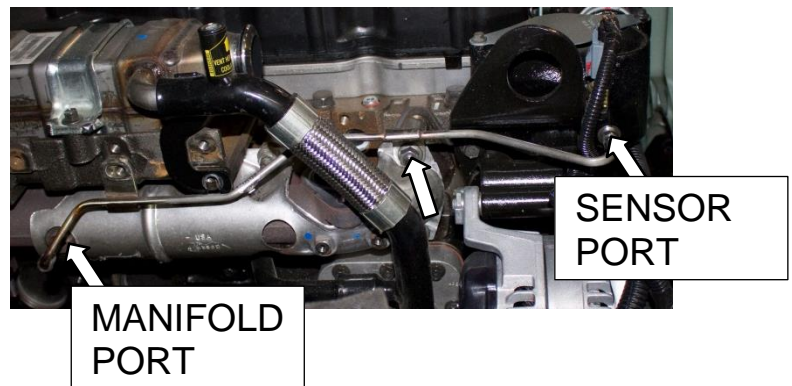

23. Remove two 15mm nuts securing EGR cooler to exhaust manifold at rear.

**07-09 models only**

Move spring clamp from EGR cooler toward coolant riser pipe and loose hose connection.

24. Lift rear of cooler off studs and slide cooler back to release coolant connection.

Lift cooler from vehicle.

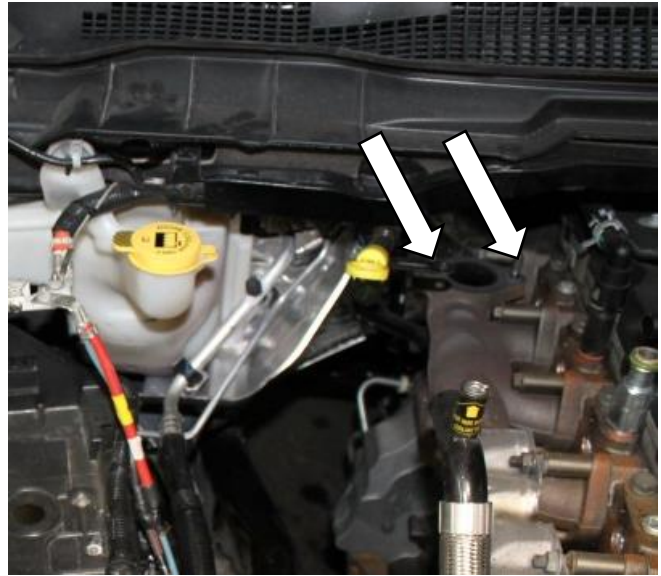

25. Remove 15mm nut and 10mm bolt securing coolant pipe to exhaust manifold.



26. Pull coolant pipe out of the way and remove the locking tabs on exhaust manifold bolts.





27. Detach exhaust manifold heat shield. Six (15mm) nuts.



28. Remove 12 (13mm) bolts on exhaust manifold and remove exhaust manifold.

29. Clean up cylinder head at mating surface.

NOTE : If the vehicle is a 2010-2012 continue on step 34



**2007.5-2009 Models Only**

30. Disconnect coolant pipe from heater core hose and vertical pipe near oil filter.

31. Remove 2 (10mm) bolts holding coolant pipe to block and 1 (15mm) nut from the exhaust manifold stud then remove pipe from vehicle. Do not remove vertical pipe.

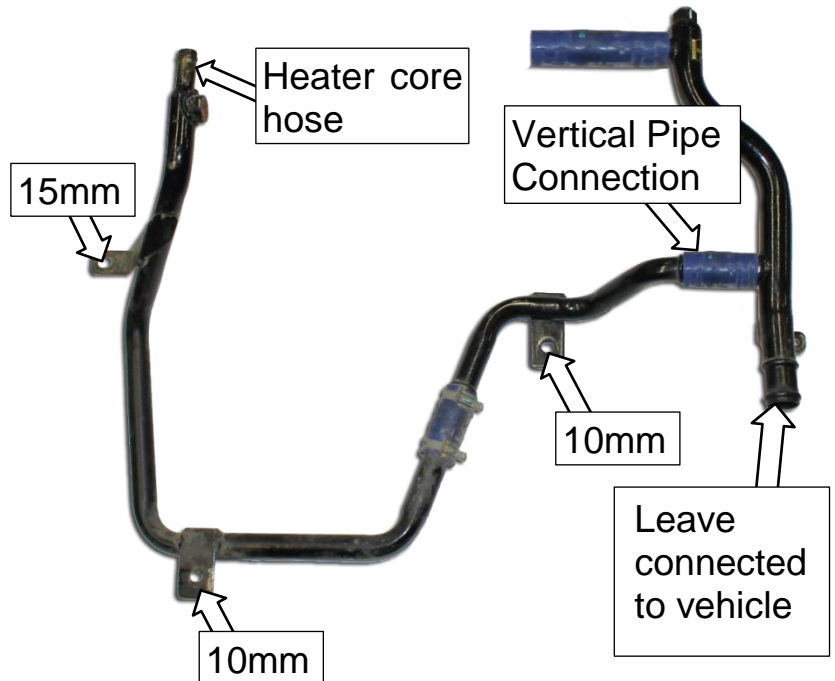

32. Install 7/8" coolant plug into hose with gear clamp and tighten section remaining on vertical pipe.

33. Trim heater core hose directly after 90° bend (see diagram below). The 5/8" to 3/4" hose mender can be inserted into the remaining heater core hose. Install and tighten gear clamp on the 5/8"

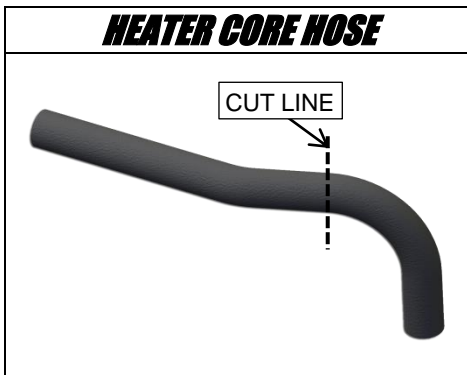
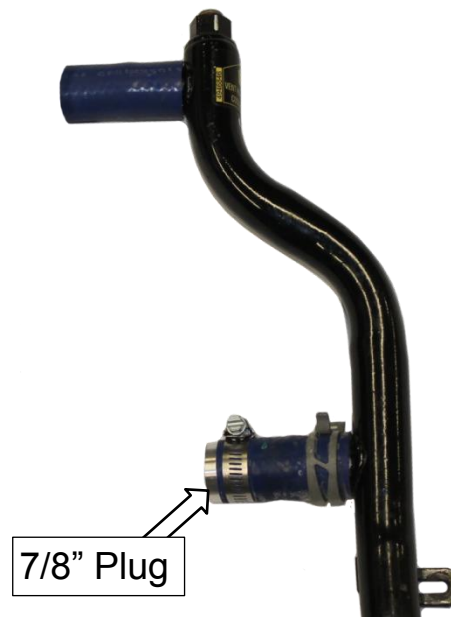

- 34. Prep BD Exhaust manifold for installation by installing 1/8" NPT plugs or pyro adapters into testing ports.
- 35. Insert dual volute gasket between exhaust manifold & turbo.

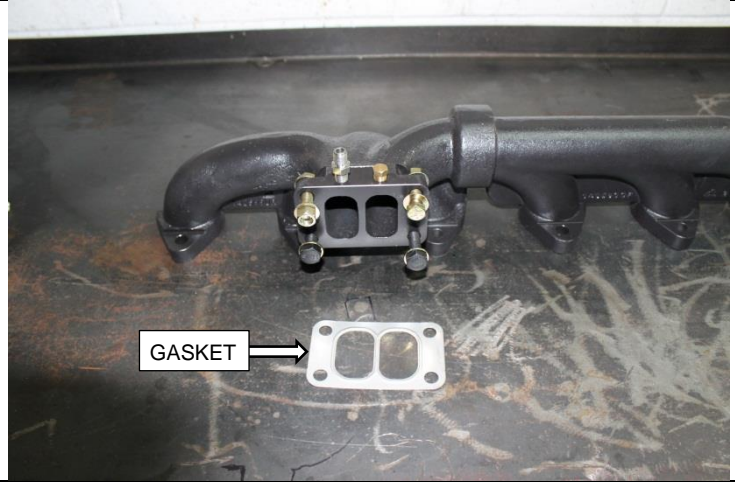

- 36. Attach turbo to BD manifold using the 2 supplied 3/8" NF X 1.5" bolts, nuts and washers inserted into the drilled holes and (1) M10 x 1.5 x 20mm bolt with flat washer in rear threaded hole. M10x1.5x30mm bolt and washer are used in the front threaded hole. (9/16" or 14mm wrench)



Remove oil feed fitting from stock turbo and install in BD turbo.(19mm)

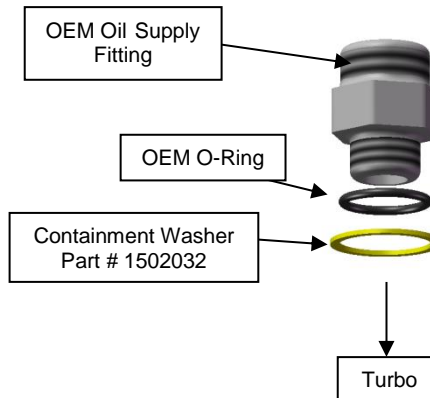



37. Carefully lift turbo/manifold assembly into engine bay. Mount assembly to cylinder head using new gaskets and OEM bolts (13mm) Torque to 35 ft/lbs.
38. Reattach coolant pipe to exhaust manifold stud (15mm nut) and block bolt (10mm)



39. Insert BD oil drain adapter until the shoulder touches the block.

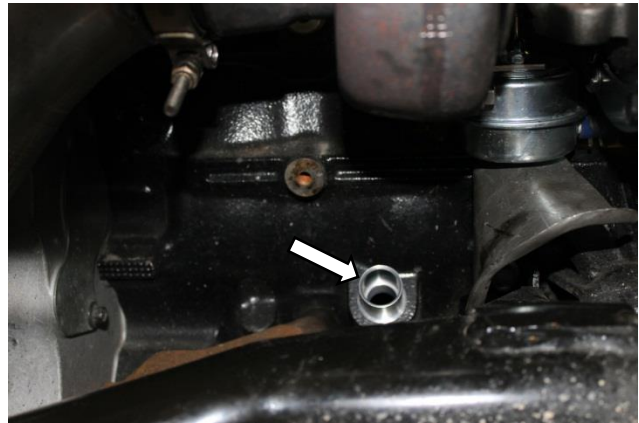

40. Insert flexible OEM turbo oil drain into adapter and fasten oil drain to turbo using the original 10mm bolts and new gasket.

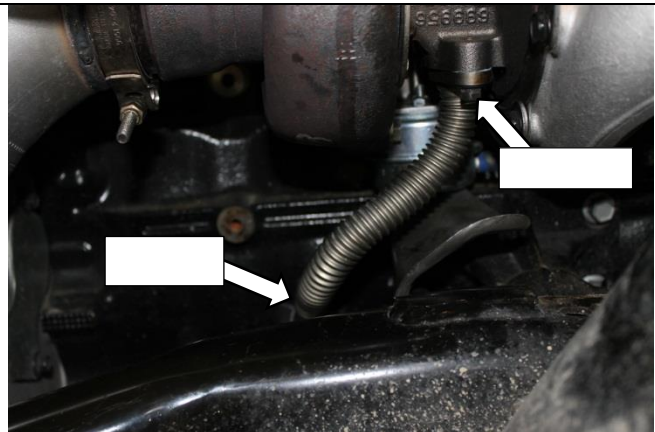

41. Lift truck, support transmission and remove cross member.

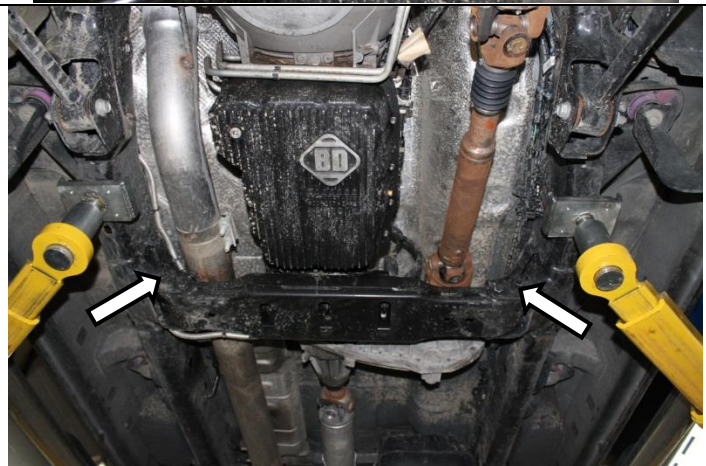

BD Engine Brake Inc.

Plant Address: 33541 MacLure Rd. Abbotsford, BC, Canada V2S 7W2

U.S. Shipping Address: 88-446 Harrison St, Sumas, WA 98295 U.S. Mailing Address: P.O. Box 231, Sumas, WA 98295

Phone: 604-853-6096 | Fax: 604-853-8749 | Internet: www.bd-power.com

42. Using the supplied V-band clamp connect the downpipe to the turbine outlet and tighten hand tight. Exhaust pipes may need to be trimmed to connect with downpipe , once pipes are connected tighten v band clamp.

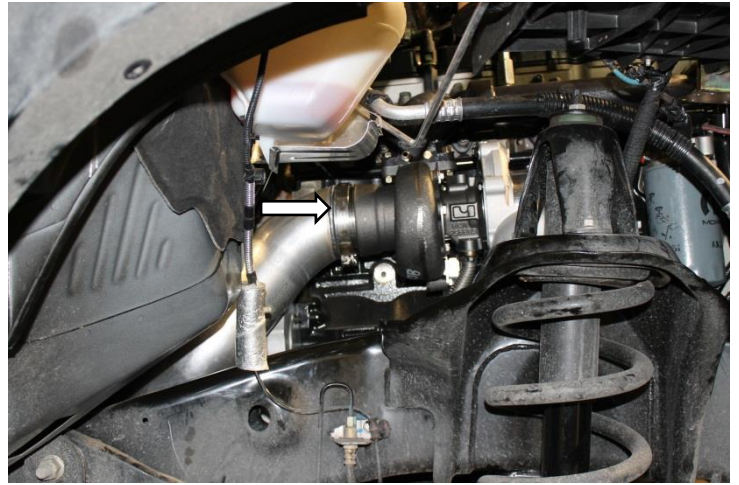

43. Reinstall exhaust hanger onto bell housing.

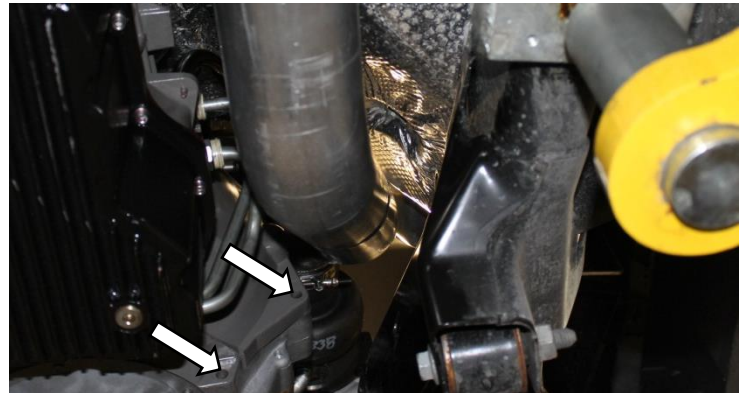

44. Reinstall cross member then lower vehicle.

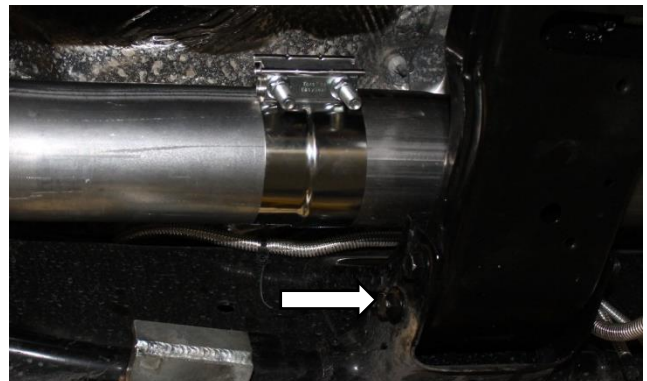

BD Engine Brake Inc.

Plant Address: 33541 MacLure Rd. Abbotsford, BC, Canada V2S 7W2

U.S. Shipping Address: 88-446 Harrison St, Sumas, WA 98295 U.S. Mailing Address: P.O. Box 231, Sumas, WA 98295

Phone: 604-853-6096 | Fax: 604-853-8749 | Internet: [www.bd-power.com](http://www.bd-power.com)



45. Preoil turbo by putting oil in through oil fitting then reattach oil feed line.



46. Tape VGT Turbo Connections to keep dirt and moisture out.



BD Engine Brake Inc.

Plant Address: 33541 MacLure Rd. Abbotsford, BC, Canada V2S 7W2

U.S. Shipping Address: 88-446 Harrison St, Sumas, WA 98295 U.S. Mailing Address: P.O. Box 231, Sumas, WA 98295

Phone: 604-853-6096 | Fax: 604-853-8749 | Internet: [www.bd-power.com](http://www.bd-power.com)



47. Discard hoses 2 and 10.  
(photo below)

At the block and coolant tube, use the provided sleeves (P/N# 1600035) to replicate the now removed banjo hose. Ensure to surround the sleeve with the OE washers and then insert the banjo bolt and tighten.

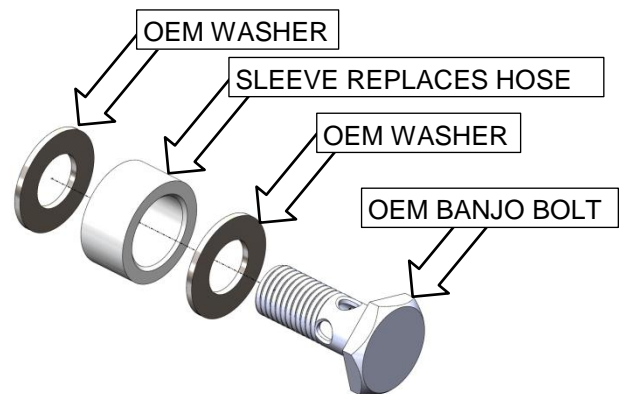
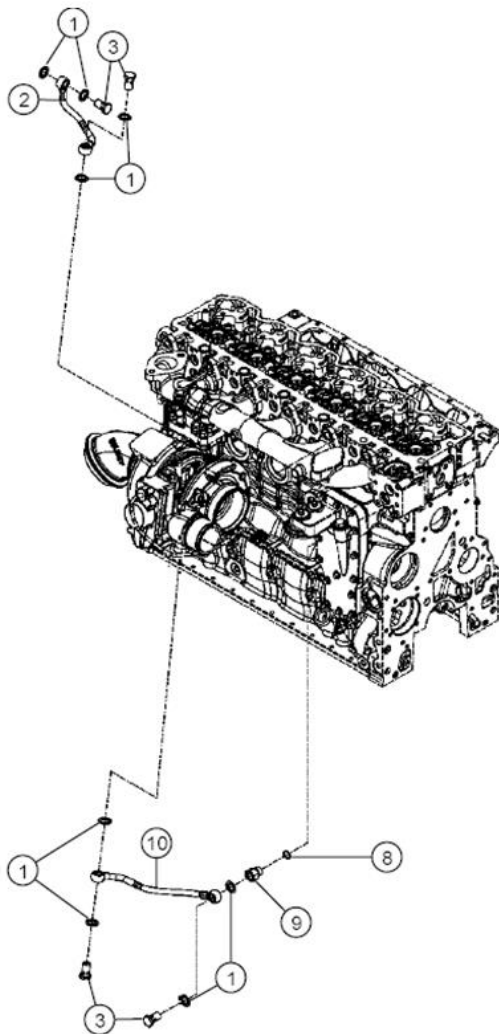
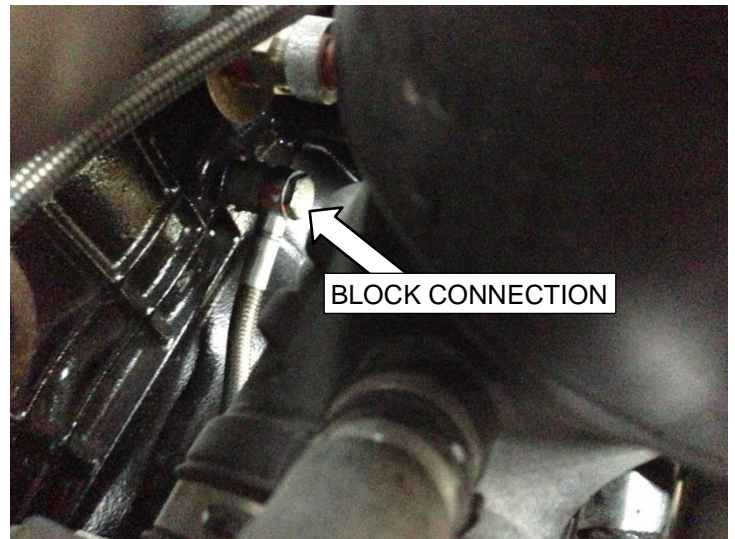
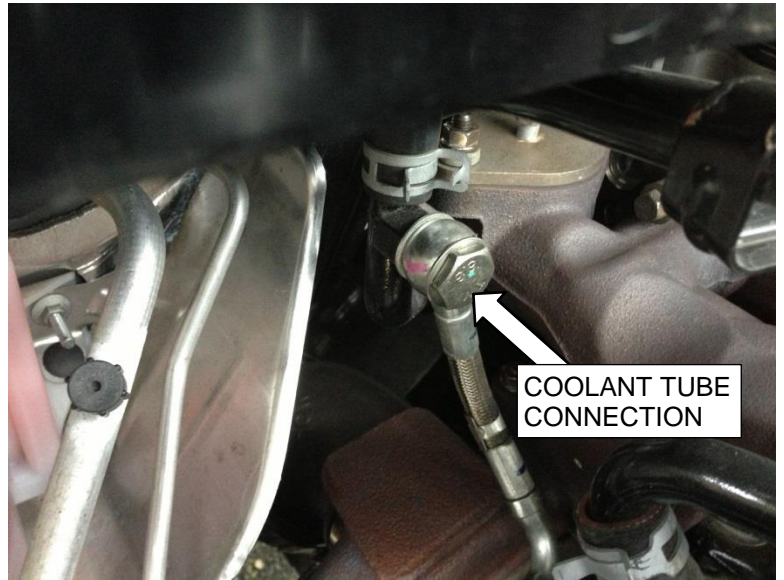

48. Reinstall OEM CAC pipe and tighten clamps. Clock compressor cover if necessary for proper alignment.

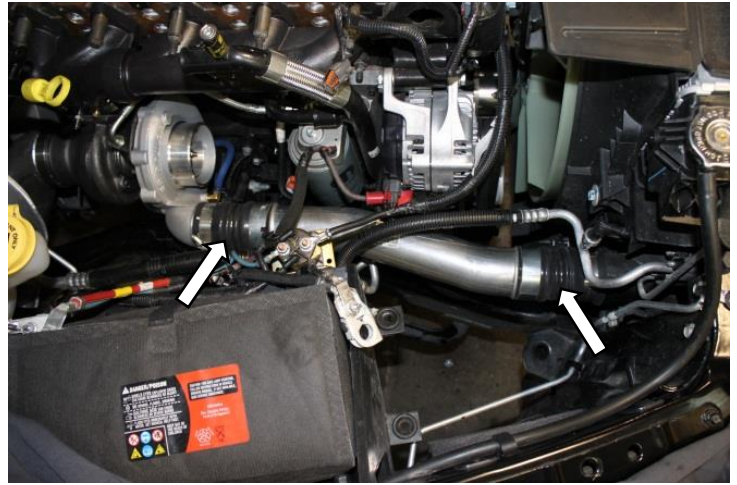

49. Remove coolant fitting from cylinder head with 1" wrench and install supplied pipe plug 3/8" square drive.



BD Engine Brake Inc.

Plant Address: 33541 MacLure Rd. Abbotsford, BC, Canada V2S 7W2

U.S. Shipping Address: 88-446 Harrison St, Sumas, WA 98295 U.S. Mailing Address: P.O. Box 231, Sumas, WA 98295

Phone: 604-853-6096 | Fax: 604-853-8749 | Internet: [www.bd-power.com](http://www.bd-power.com)

**2007.5-2009 Models**

50. Remove 3/4" coolant hose section from upper outlet of vertical coolant pipe.
51. Install supplied 3/4" silicone coolant hose between outlet and hose mender secure with gear clamps.

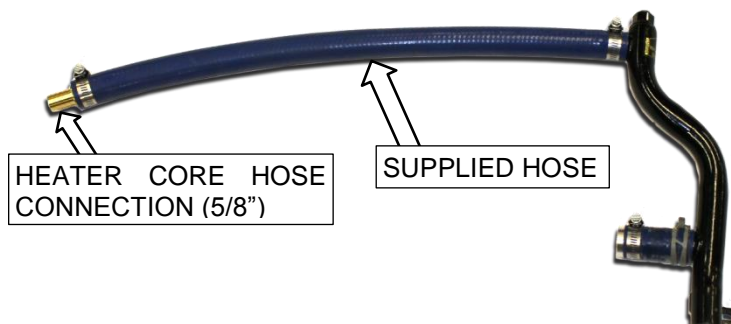

52. Install insulated clamp onto silicone hose with supplied M6 bolt/washer/nut to supplied bracket and tighten
53. Mount bracket to transmission dip stick mounting stud on EGB Bracket.

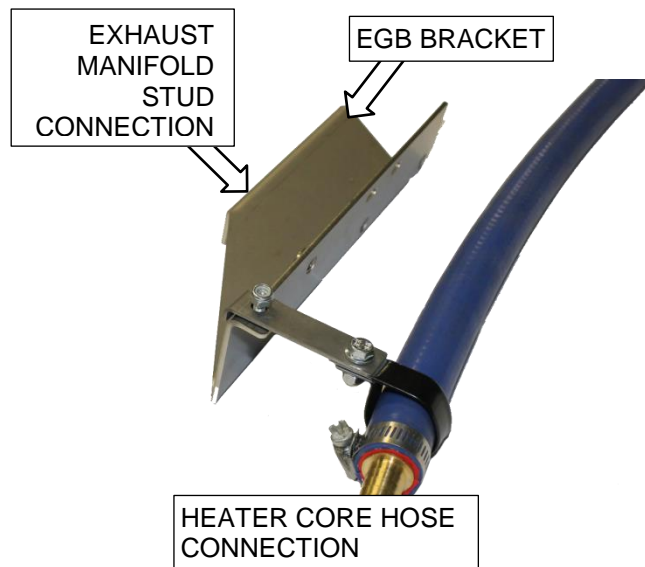



**2010-2012 Models**

54. Install support bracket onto exhaust manifold with 2-15mm nuts from heat shield removal.

Mount coolant pipe to support bracket with OEM 10mm bolt. Insert plug into coolant pipe with provided orings. Install bracket from coolant plug to support bracket with OEM 10mm bolt.

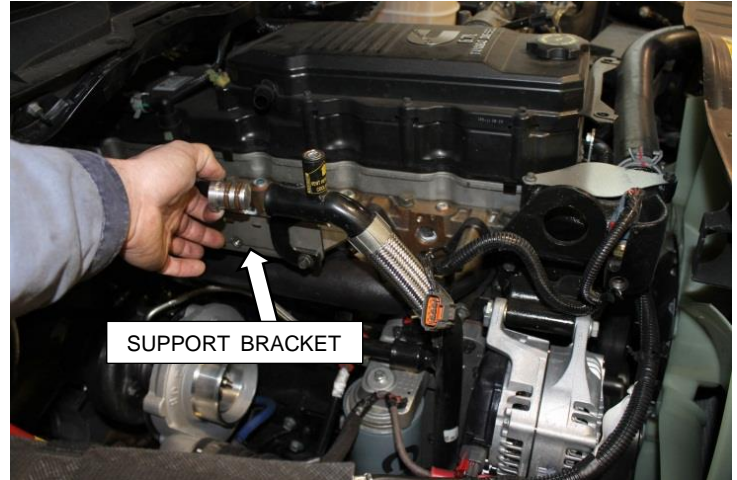

BD Engine Brake Inc.

Plant Address: 33541 MacLure Rd. Abbotsford, BC, Canada V2S 7W2

U.S. Shipping Address: 88-446 Harrison St, Sumas, WA 98295 U.S. Mailing Address: P.O. Box 231, Sumas, WA 98295

Phone: 604-853-6096 | Fax: 604-853-8749 | Internet: [www.bd-power.com](http://www.bd-power.com)

**Installation Continued**

55. Mount transmission dipstick tube to support bracket with OEM 10mm nut.



56. Remove and disconnect EGR valve from intake horn.  
4 (10mm bolts)



57. Install block off plates with new gaskets provided. Reuse 4-10mm mounting bolts.

58. Disconnect throttle valve connector located under intake horn.

59. Tape each connector end including EGR cooler valve connector and zap strap wires to secure in place.



BD Engine Brake Inc.

Plant Address: 33541 MacLure Rd. Abbotsford, BC, Canada V2S 7W2

U.S. Shipping Address: 88-446 Harrison St, Sumas, WA 98295 U.S. Mailing Address: P.O. Box 231, Sumas, WA 98295

Phone: 604-853-6096 | Fax: 604-853-8749 | Internet: [www.bd-power.com](http://www.bd-power.com)

60. Reinstall air box and reconnect sensors. Then install the intake tube with PCV hose and secure PCV to bracket with OEM bolt.(10mm)



61. Reinstall inner fender and wheel torque wheel nuts to manufacturer specifications.



Refill coolant and reconnect negative battery terminals.

Take it easy on the turbo for the first 100 miles to allow a proper break-in period. Be very cautious of any unusual sounds or leaks during this time. Make sure that all clamps are tight.

**Note:** The exhaust housing of the turbo may smoke when new as manufacturing residue on housing must burn off.

Also take care that when shutting the vehicle down that your EGT's are below 400°. EGT's hotter than this will cause oil coking and damage the turbo. The **BD Cool Down Timer** can automate this process for you.

**\*IMPORTANT\*** When idled for any length of time some oil may leak from the turbo. If the performance/boost is satisfactory and the wheel is not touching the housing (There will be some small movement), the excess oil is not a concern. Simply wipe with a clean cotton cloth and continue use.

## Questions

Please call our Technical Hotline at (800) 887-5030 if you experience problems or have questions about this kit, Monday to Friday, 8:30am – 5:00pm Pacific Standard Time (PST)

BD Engine Brake Inc.

Plant Address: 33541 MacLure Rd. Abbotsford, BC, Canada V2S 7W2

U.S. Shipping Address: 88-446 Harrison St, Sumas, WA 98295 U.S. Mailing Address: P.O. Box 231, Sumas, WA 98295

Phone: 604-853-6096 | Fax: 604-853-8749 | Internet: www.bd-power.com