

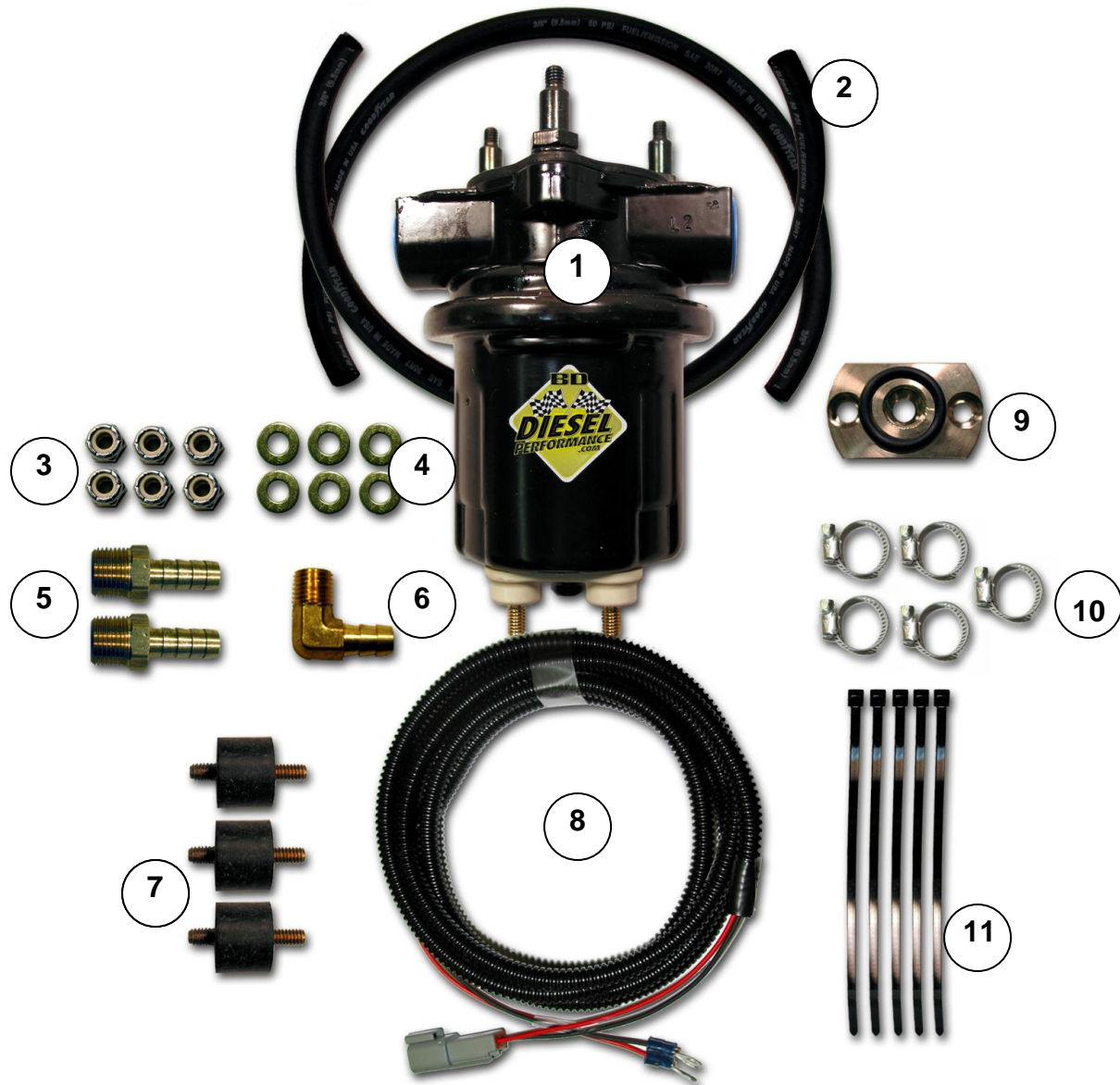

2003-04¹/₂ DODGE CUMMINS
OEM BYPASS LIFT PUMP KIT
Installation Instructions
Part # 1050227

PLEASE READ ALL INSTRUCTIONS CAREFULLY BEFORE INSTALLATION.

The BD auxiliary lift pump kit will provide the safety and performance of enhanced fuel flow to your Cummins engine.

Kit Contents:

- 1. P4601HP - 100GPH Fuel Pump (Qty. 1)** – contains additional parts – only use the following:
- 2 – Hose Clamps
 - 3 – Rubber Isolators
 - 2 – Nuts w/ Lock Washers
- 2. 1502021 – Fuel Hose (24") (Qty. 2)**
- 3. 1230116 – Nylock Nut (Qty. 6)**
- 4. 1100111 – Flat Washer (Qty. 6)**
- 5. 1400120 – Straight Fitting (Qty. 2)**
- 6. 1604110 – 90° Fitting (Qty. 1)**
- 7. 1300220 – Anti-Vibration Mount (Qty. 3)**
- 8. 1502027 – Wiring Harness (Qty. 1)**
- 9. 1502028 / 1502029 – OEM Adapter & O-Ring (Qty. 1)**
- 10. 1505001 – Hose Clamp (Qty. 5)**
- 11. 1300131 – Tie Wraps (Qty. 5)**

NOTE: Some parts will be contained inside of the sealed plastic bag found inside of the pump kit. You will not use all these parts.

BD Engine Brake Inc.

Plant Address: 33541 MacLure Rd. Abbotsford, BC, Canada V2S 7W2

U.S. Shipping Address: 88-446 Harrison St, Sumas, WA 98295 U.S. Mailing Address: P.O. Box 231, Sumas, WA 98295

Phone: 604-853-6096 | Fax: 604-853-8749 | Internet: www.bd-power.com

Before You Begin

This pump kit is designed to be a stand-alone system and is not designed to be used in conjunction with stock lift pumps. If your truck has been retrofitted with the Chrysler in-tank lift pump you will have to lower the fuel tank & delete the pump from in the tank. BD offers a simple retrofit kit complete with instructions & the pieces needed to do this, part number 1050302. If you are unsure if your truck has been retrofitted simply check that the factory lift pump is still in place on the engine next to the fuel filter housing (see diagram below); if it is not there then your truck has the in-tank pump.

Optional Accessories:

- **1081130** - Low Fuel Pressure LED Alarm kit
- **1085220** – X-Monitor Digital Gauge Package (2003-05)
- **1080156** – Fuel Pressure Kit (X-Monitor Accessory)

Installation:

1. Disconnect both batteries.
2. Raise the vehicle and support it safely.
3. Locate and remove the factory lift pump. The pump is supported by 5mm socket cap screws.

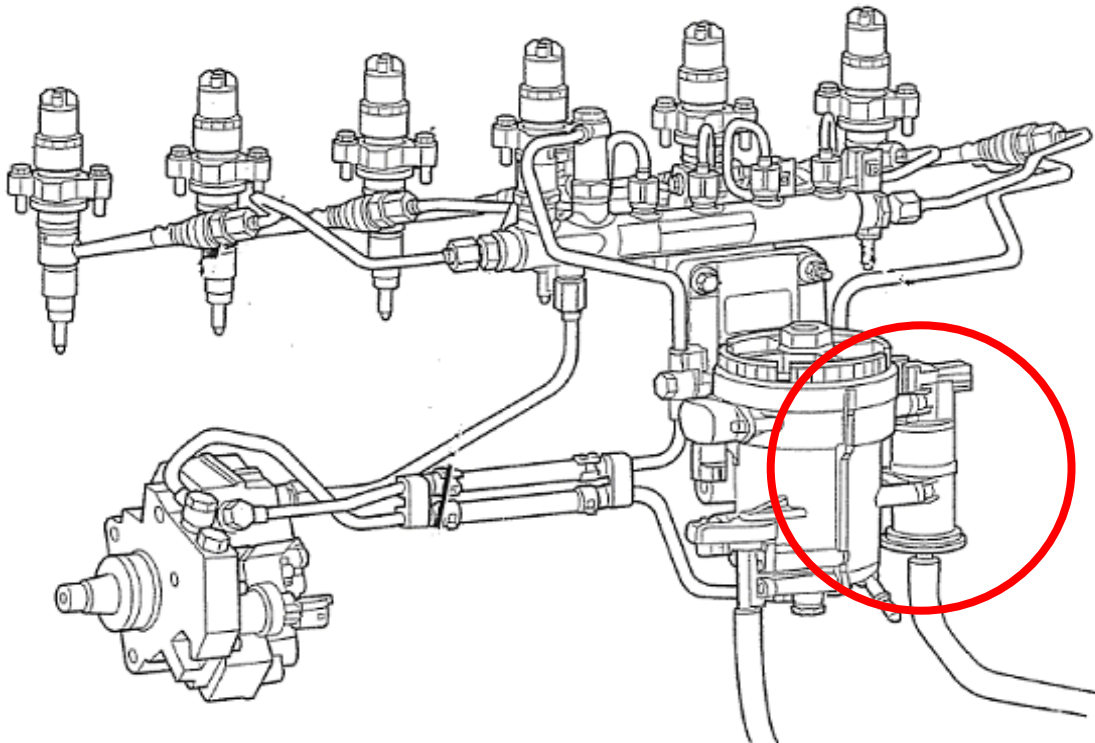

BD Engine Brake Inc.

Plant Address: 33541 MacLure Rd. Abbotsford, BC, Canada V2S 7W2

U.S. Shipping Address: 88-446 Harrison St, Sumas, WA 98295 U.S. Mailing Address: P.O. Box 231, Sumas, WA 98295

Phone: 604-853-6096 | Fax: 604-853-8749 | Internet: www.bd-power.com

4. Install the brass 90° NPT to barb fitting into the supplied aluminum pump bypass bracket. The brass elbow should be orientated so that the barbed end points down or oriented 90° to the mounting holes. You will need to use Teflon sealant to seal the threads.
5. Install the new o-ring to fuel filter end of the adapter. Be sure to lubricate the o-ring before installing.
6. Position and press the bypass adapter onto fuel filter housing. **Do not use mounting bolts to draw bypass adapter in to the filter housing.**
7. Be sure the bypass adapter is positioned flat to the fuel filter housing. Install mounting bolts and evenly tighten to 7 N·m (61 in. lbs.).
8. Connect fuel line extension hose to the brass barb fuel fitting. Make sure that by re-routing the hose it doesn't rub on anything. **Some trucks were equipped with a fuel transfer pump that has a permanently attached hard plastic line which will need to be replaced with Cummins p/n 3969705, Chrysler p/n 5133196AB, or the supplied 24" hose and clamp.**



Pump Installation

9. Locate a spot on the driver's side frame rail near the frame opening so you can get the nuts and lock washers onto the back of the rubber isolators. Alternately if you cannot get to the backside frame to install the lock washers and nuts, you can drill and tap the holes to ¼ NC (drill bit #7 or 13/64") for mounting the rubber isolators. If you choose this method be sure to use Loc-tite on the threads.

Locate the largest fuel line. This line should be upper most line on the frame rail. Drill and tap the frame rail to 1/4" NC (drill bit #7 or 13/64") as there is no frame opening. Be sure to use Loc-tite to secure the isolators.

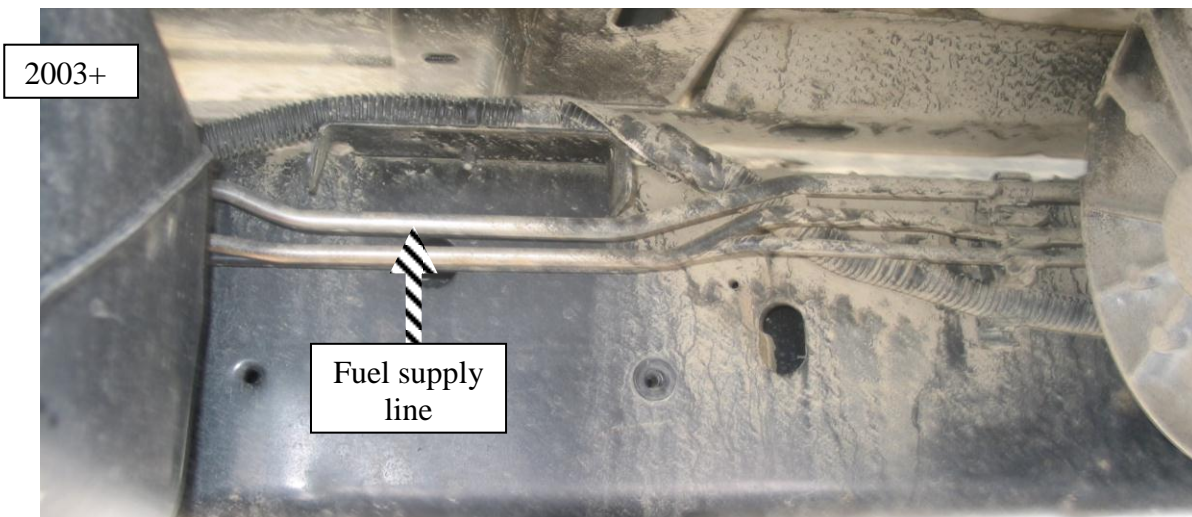

BD Engine Brake Inc.

Plant Address: 33541 MacLure Rd. Abbotsford, BC, Canada V2S 7W2

U.S. Shipping Address: 88-446 Harrison St, Sumas, WA 98295 U.S. Mailing Address: P.O. Box 231, Sumas, WA 98295

Phone: 604-853-6096 | Fax: 604-853-8749 | Internet: www.bd-power.com

10. Cut the steel fuel supply line and remove a 14" section, centered on the location you chose to mount the mounting at. A pipe cutter is strongly recommended to cut the line, be sure not to squish or compress the fuel line, and remove any burrs that are left over from the process.



Lift Pump Bracket

11. Using the pump bracket as a template, mark the three hole locations as shown and drill to 1/4". If you cannot access the rear of the frame rail you will need to drill and tap the three holes. Use drill bit #7 or 13/64, then tap to 1/4" NC.
12. Install the three rubber isolators with the long threaded end through the frame. Be sure to use Loc-tite if you are threading the isolators into the frame.
13. Install the pump bracket on to the three rubber isolators with the supplied nuts and lock washers (These parts are found inside the sealed bag inside the pump box). Mount the pump to the "L" bracket with the supplied isolators and bolts. The pump is marked inlet and outlet so be sure that the outlet is pointed of the front the front of the vehicle.
14. Install the two brass fittings in the pump - Do not use any thread sealant as this may void the warranty of the pump.
15. Install the two pieces of rubber fuel lines with one clamp on each barb fitting and two on the steel line. Tighten the hose clamps on the factory fuel line and the brass-barbed fittings.



16. Connect the wiring harness to the pump (red [+], black [-]) and run it to engine compartment along the left frame rail, securing it along the way with the provided zip ties. Then attach the harness to the factory lift pump connector on the driver's side of the engine. Coat the lift pump connections with some type of anti-seize, silicone, or battery terminal paint to protect them against corrosion.
17. Reconnect the batteries and reset the radio station presets.

18. Start your engine, and verify that your auxiliary pump starts when your oil pressure builds up. Check for fuel and oil leaks at the various connections made during the installation. It is also recommended that you monitor the fuel pressure initial to ensure proper operation. Typically fuel pressure at idle should be around 14psi.

If you experience any problems or difficulties with this kit, please contact the BD Technical Department at 1-604-853-6096 or fax at 1-604-853-8749, between 8:00am and 4:30pm Pacific Time.

BD Engine Brake Inc.

Plant Address: 33541 MacLure Rd. Abbotsford, BC, Canada V2S 7W2

U.S. Shipping Address: 88-446 Harrison St, Sumas, WA 98295 U.S. Mailing Address: P.O. Box 231, Sumas, WA 98295

Phone: 604-853-6096 | Fax: 604-853-8749 | Internet: www.bd-power.com