



9255 Archibald Ave.
 Rancho Cucamonga, CA 91730
 (909) 476-7225 TECH SUPPORT
 (909) 476-1491 FAX
 www.volant.com

INSTALLATION INSTRUCTIONS PART NO. 16867

READ INSTRUCTIONS THOROUGHLY BEFORE DISASSEMBLING.
 DO NOT SKIP ANY STEPS. ANY QUESTIONS ON A VOLANT KIT
 MAY BE REFERRED TO OUR TECH SUPPORT LINE AT
 (909) 476-7225 OR VISIT OUR WEBSITE AT WWW.VOLANT.COM

TOOLS NEEDED FOR INSTALL:

1. 5/16" SOCKET WRENCH
2. 10 MM SOCKET
3. 14 MM SOCKET AND RATCHET WRENCH
4. PHILLIP SCREWDRIVER

INSTALLATION:

1. Volant Cool Air Intake for Dodge 6.7 2008.
2. Disconnect negative battery cables.
3. Unclip MAF sensor and air temperature sensor.
4. Remove 10mm bolt holding the factory air box to the core support.
5. Loosen the clamp holding the factory air duct to air box.
6. Pull stock duct off of air box.
7. Remove factory air box by pulling up and out.
8. Loosen clamp on the elbow and leave the clamp on the turbo tight. Remove factory air duct from engine compartment.
9. Install U-nuts on factory battery box.
10. Place Volant Filter Box into factory position.
11. Tighten box down with the supplied 3/8" bolts, lock washers and washers.
12. Attach 4" hump hose to filter adapter tighten with #064 clamp.
13. Remove air temp sensor from the factory air duct with the torx bit provided.

14. Install the temp into the upper hole on the Volant Air Duct attach with factory screw.
15. Remove the factory MAF from the factory air duct with the torx bit provided.
16. Install the MAF into lower hole on Volant Air Duct tighten with factory screw.
17. Attach the Volant Air Duct to the factory elbow.
18. Attach the Volant Air Duct to the factory elbow with a #064 clamp.
19. Attach Volant Ram Filter to filter adapter and tighten clamp.
20. Attach lid to volant air box.
21. Clip air temp sensor and MAF back. Tighten battery cables.

WARNING: OVER TIGHTENING HARDWARE MAY ALTAR THE INTEGRITY OF THE VOLANT AIR INTAKE SYSTEM.

BEFORE ROAD TESTING

1. Start engine, leaving the transmission in park and securing the parking brake.
2. Make sure to look and listen for any unusual noises or air leaks. Repair problems if needed.
3. Once completed it will be necessary to check periodically for realignment and tightening of all connections.
4. Once all tests are completed, enjoy the performance of your new Volant Air Intake System.

CARE AND CLEANING

Check the cotton reusable filter periodically and remove any excessive dirt build-up by tapping the filter on the ground and brushing off the loosened dirt. Clean the filter by using Volant's Filter Recharger Kit. Volant's Filter Recharger Kit is designed to restore original air flow. Re-oil every 10,000 miles without cleaning to improve filtering in sand and dirt. Clean only when dirt is very excessive or 50,000 miles.

APPLICATION GUIDE

PART NO. 16867

MY	MAKE	MODEL	ENG.
2008	DODGE	CUMMINS	6.7L

RECOMMENDED SERVICE PARTS PART NO.

VOLANT COOL AIR SCOOP	36867
VOLANT REPLACEMENT FILTER	5150
VOLANT RECHARGER KIT	5100
VOLANT PREFILTER	51906

POWERCORE REPLACEMENT FILTER	61559
------------------------------	-------

The Volant PowerCore™ filter will excel in airflow performance, filtration efficiency, dust holding capacity and compact size, and will be backed with the PowerCore™ no-maintenance, 100,000-mile warranty.



VOLANT AIR INTAKE SYSTEMS
 PART NO.: 16867
 INSTALLATION INSTRUCTIONS
 WWW.VOLANT.COM
 TECH SUPPORT: (909) 476-7225

16867 PARTS LIST

1	VOLANT FILTER BOX	3	1/4"-20 BOLTS	5	1/4" RUBBER WASHERS
1	VOLANT FILTER BOX LID	2	3/8" BOLT	1	RUBBER GASKET
1	VOLANT FILTER BOX ADAPTER	3	1/4" LOCK WASHERS		
1	VOLANT AIR DUCT	3	1/4" WASHERS		
1	RAM FILTER W/CLAMP	2	3/8" WASHER		
1	4' X 4 1/2' HUMPH HOSE REDCOR	2	3/8" LOCK WASHER		
2	#064 CLAMPS	5	1/4"-20 TRUSS HEAD SCREWS		

SIDE VIEW

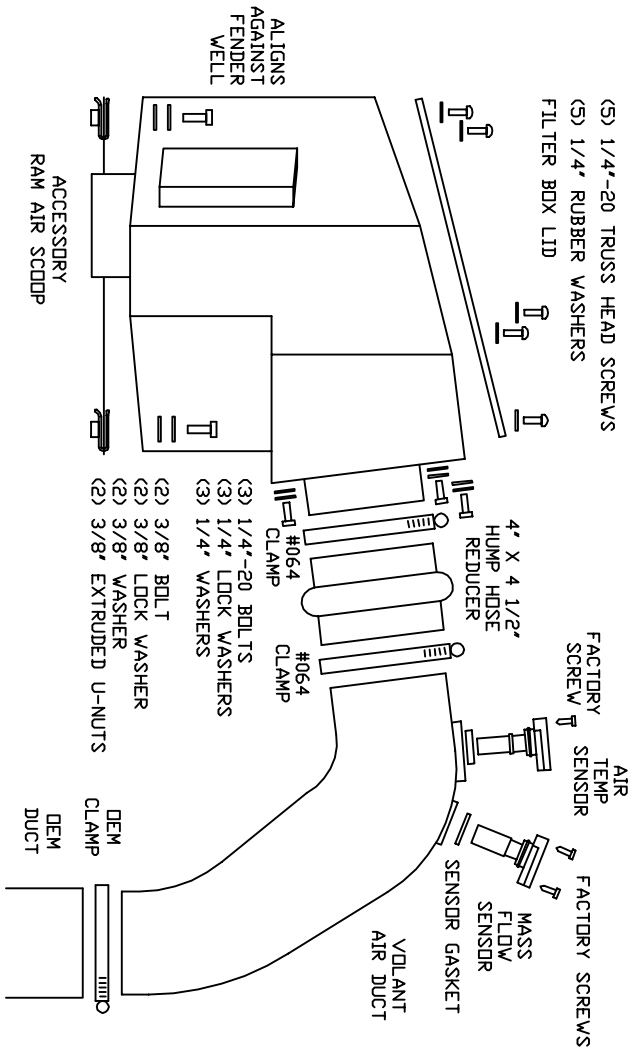

TOP VIEW

