



BD DODGE CUMMINS 5.9L 94-02
COOL-IT INTERCOOLER
Installation Instructions

P/N# 1042520

PLEASE READ ALL INSTRUCTIONS BEFORE INSTALLATION.

UNLESS AN EO# IS LISTED, THIS PRODUCT IS LEGAL IN CALIFORNIA FOR RACING VEHICLES ONLY, WHICH MAY NEVER BE USED UPON A HIGHWAY.

BD ENGINE BRAKE, INC.
Plant Address: A10-33733 King Rd, Abbotsford, BC, Canada V2S 7M9
US Shipping Address: 88-446 Harrison St, Sumas, WA 98295 US Mailing Address: PO Box 231, Sumas, WA 98295
Phone: 604-853-6096 Fax: 604-853-8749 Internet: www.bd-power.com

Options

Description	Part #
BD 94-02 Intercooler Hose kit	1045210
Super B Turbo Kit 1994-02	1045230
Twin Turbo Kit 1994-98	1045310
Twin Turbo Kit 98.5-02	1045320

Removal

Record your radio station presets and then disconnect both negative battery terminals.

Bumper Removal

Observe the bumper alignment so upon reinstallation you can get it back to suitable alignment. Some vehicles may have been previously damaged preventing proper bumper alignment and this should be noted before you begin.

Support the front bumper on a suitable lifting device. Remove the bolts that attach the front bumper outer bracket to the frame rail. Remove the nuts and stud plates attaching the front bumper to the end of the frame rail.

Disengage wire connectors from fog lamps, if equipped, and then separate the front bumper from the vehicle.

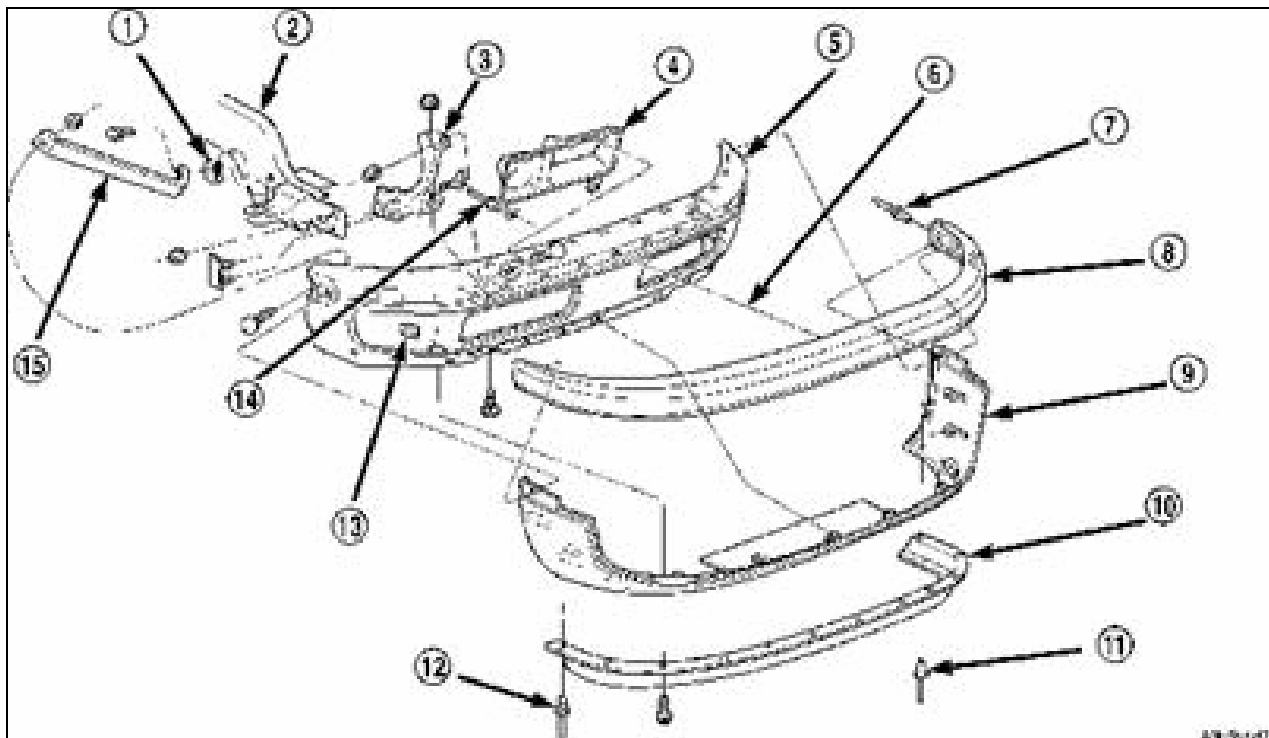

BD ENGINE BRAKE, INC.

Plant Address: A10-33733 King Rd, Abbotsford, BC, Canada V2S 7M9

US Shipping Address: 88-446 Harrison St, Sumas, WA 98295 US Mailing Address: PO Box 231, Sumas, WA 98295

Phone: 604-853-6096 Fax: 604-853-8749 Internet: www.bd-power.com

Fan Blade Removal

Drain enough coolant to be able to remove the upper radiator hose, and then remove the upper radiator hose.

Remove the fan shroud mounting bolts. Position the fan shroud towards engine.

CAUTION: Do not remove the fan pulley bolts. This pulley is under spring tension.

The thermal viscous fan drive/fan blade assembly is attached (threaded) to the fan hub shaft. Remove the fan blade/fan drive assembly from the fan pulley by turning the mounting nut clockwise (as viewed from front). Threads on the viscous fan drive are **LEFT-HAND**. A Snap-On 36mm Fan Wrench (number SP346 from Snap-On Cummins Diesel Tool Set number 2017DSP) can be used. Place a bar or screwdriver between the fan pulley bolts to prevent the pulley from rotating. **You can make a special fan wrench by grinding a 36mm wrench thinner on the open end.**

Remove the fan shroud and the fan blade/viscous drive as an assembly from vehicle.

Remove the fan blade-to-viscous fan drive mounting bolts.

Inspect the fan for cracks, loose rivets, loose or bent fan blades.

AC Condenser & Transmission Cooler Removal (if equipped)

There are 2 nuts and 2 bolts mounting the AC condenser to the intercooler. Remove them and save them for reuse. Swing the AC condenser out of the way, but be sure not to kink the aluminum lines or overstress the fittings which could cause them to discharge. Hang the condenser from the hood using rope, wire, or bungee cords.

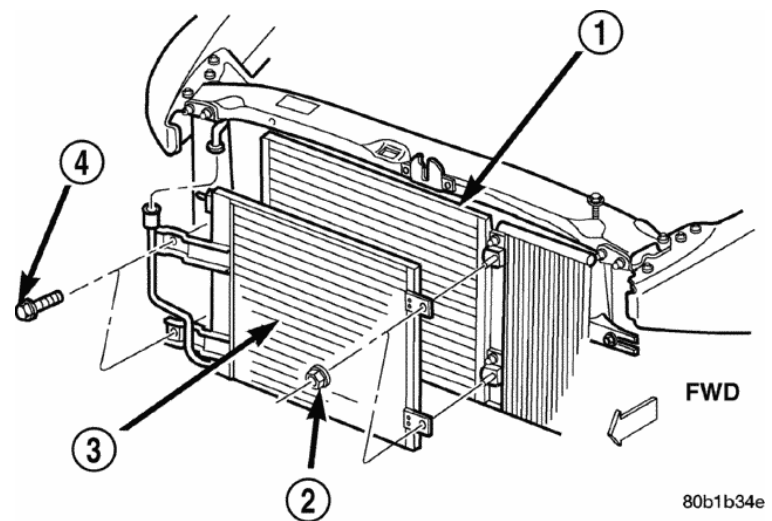
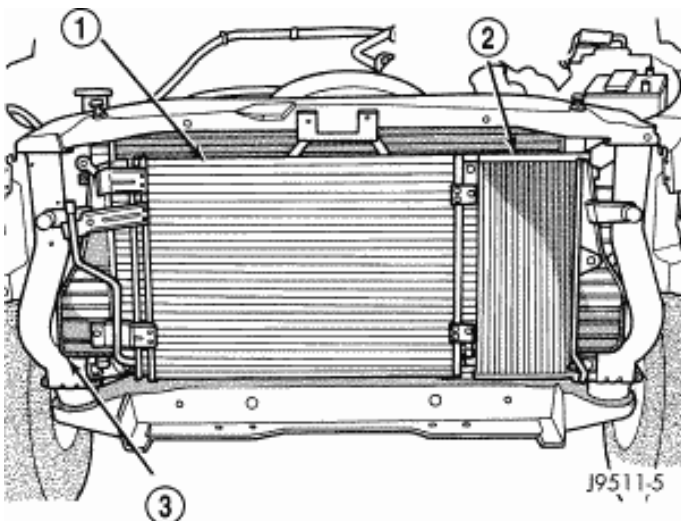

BD ENGINE BRAKE, INC.

Plant Address: A10-33733 King Rd, Abbotsford, BC, Canada V2S 7M9

US Shipping Address: 88-446 Harrison St, Sumas, WA 98295 US Mailing Address: PO Box 231, Sumas, WA 98295

Phone: 604-853-6096 Fax: 604-853-8749 Internet: www.bd-power.com

Intercooler Removal

Disconnect the charge air hoses from the intercooler and remove them completely.

Remove the 2 bolts securing the intercooler to the radiator support.

Remove the 2 bolts securing the radiator to the radiator support. Using an engine lifter or a couple of assistants, raise the radiator just high enough to slip the intercooler out; you will have to lift the intercooler up to pull the pins out of the lower mounts.



BD ENGINE BRAKE, INC.

Plant Address: A10-33733 King Rd, Abbotsford, BC, Canada V2S 7M9

US Shipping Address: 88-446 Harrison St, Sumas, WA 98295 US Mailing Address: PO Box 231, Sumas, WA 98295

Phone: 604-853-6096 Fax: 604-853-8749 Internet: www.bd-power.com

Installation

Before installation of *Cool-It* intercooler, ensure that the lower mounting rubbers are in good condition and are in their proper position.

Because of the Hi-Flow inlet and outlet tubes, you will need to roll or bend the body panel on each side of the vehicle to allow tube and boot clearance. Check this after the intercooler is installed as well.

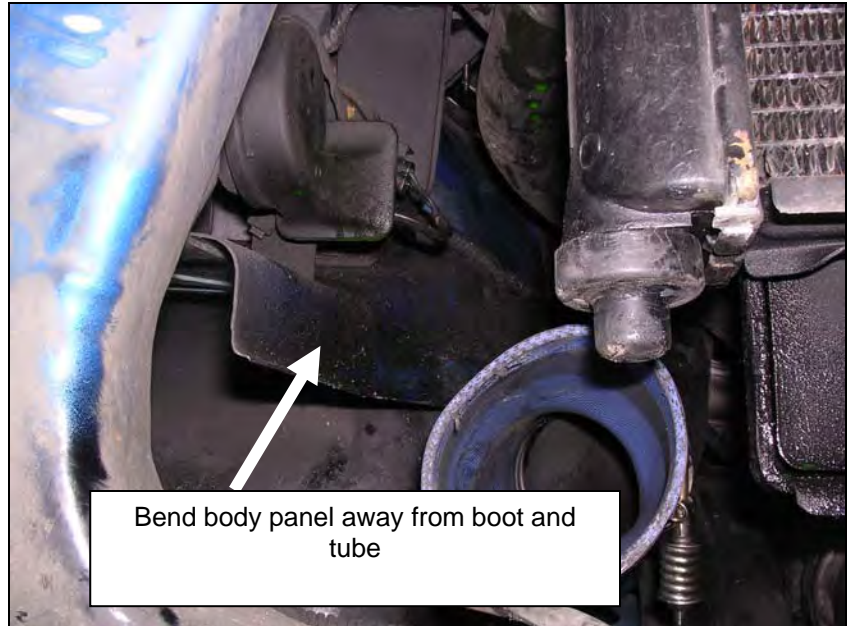

It is always helpful to have another set of hands.



BD ENGINE BRAKE, INC.

Plant Address: A10-33733 King Rd, Abbotsford, BC, Canada V2S 7M9

US Shipping Address: 88-446 Harrison St, Sumas, WA 98295 US Mailing Address: PO Box 231, Sumas, WA 98295

Phone: 604-853-6096 Fax: 604-853-8749 Internet: www.bd-power.com

When installing the intercooler, ensure that none of the transmission lines or A/C condenser lines is rubbing on the front vehicle supports.



You will need to re-use the two factory rubber spacers to secure the new intercooler.

Also check for clearance between the intercooler and front end support. Some vehicles will need a little massaging.



Reverse the removal procedure to complete the installation.

BD ENGINE BRAKE, INC.

Plant Address: A10-33733 King Rd, Abbotsford, BC, Canada V2S 7M9

US Shipping Address: 88-446 Harrison St, Sumas, WA 98295 US Mailing Address: PO Box 231, Sumas, WA 98295

Phone: 604-853-6096 Fax: 604-853-8749 Internet: www.bd-power.com