



#112494

INJECTION PERFORMANCE MODIFICATION TO CUMMINS 6BTA5.9

FUEL INJECTORS:

REMOVAL:

- 1: Disconnect both negative battery cables from both batteries.
- 2: Remove the high-pressure fuel lines. See High Pressure Fuel Line removal & installation.
- 3: Remove the fuel drain manifold. See Fuel Drain Manifold removal & installation.
- 4: Thoroughly clean the area around the injector.

Caution: When rust has formed on the fuel injector nut, (Fig 1) the injector (when being removed) can rotate in the cylinder head. This may cause damage to the cylinder head bore. Use a rust penetrating solvent before attempting to loosen a rusted holddown nut.

5. Hit the injector body with a brass drift to loosen it. (Fig 2).
- 6: Hold the injector body with one wrench while removing the injector nut with another. (Fig 3).
- 7: It may be necessary to tap the injector with an injector puller tool. (Fig 4)

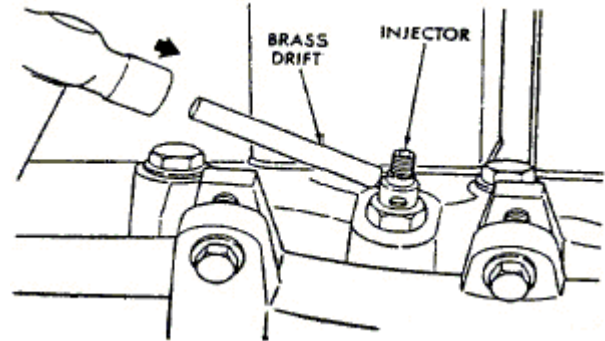

Fig 2: Loosening Injector Body

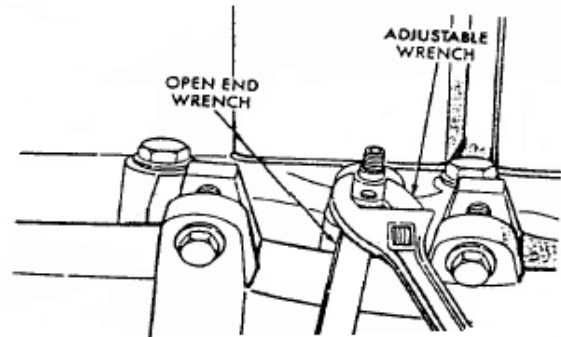

Fig 3: Loosening injector

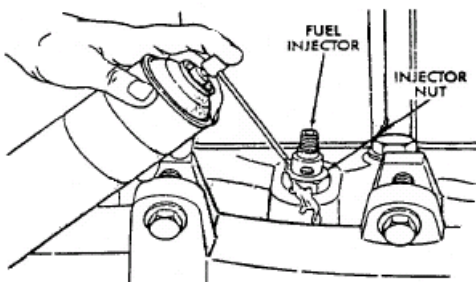

Fig 1: Loosening Injector Nut

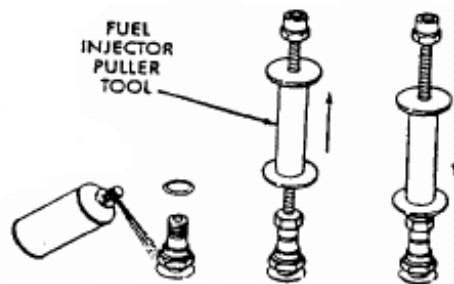

Fig 4: Removing Injector with Puller Tool

BD Engine Brake Inc.

Plant Address: 33541 MacLure Rd. Abbotsford, BC, Canada V2S 7W2

U.S. Shipping Address: 88-446 Harrison St, Sumas, WA 98295 U.S. Mailing Address: P.O. Box 231, Sumas, WA 98295

Phone: 604-853-6096 | Fax: 604-853-8749 | Internet: www.bd-power.com

***** PLEASE NOTE *****

TIP WASHERS FOR INJECTORS

Two different thicknesses of injector tip washers have been included in this kit. When installing the new injector washers, (re: figure #6) select the injector washers that are the same thickness as the used washers from the old injectors. Keeping in mind that the old washers have been crushed during the original installation, you will notice that the difference between thick and thin washers is quite evident.

It is also advisable that a performance air filter, such as a K&N or AFE brand, be installed to accommodate the extra constant airflow needed for the increase in power and boost. With automatic transmissions, the amount of variance between the torque curve of the engine and the reduction in the performance of the stock vehicle and the effect of the performance add-ons. The installation of a BD Performance torque converter is advisable to reduce the driveline slippage and greatly improve vehicle performance.

BD Engine Brake Inc.

Plant Address: 33541 MacLure Rd. Abbotsford, BC, Canada V2S 7W2

U.S. Shipping Address: 88-446 Harrison St, Sumas, WA 98295 U.S. Mailing Address: P.O. Box 231, Sumas, WA 98295

Phone: 604-853-6096 | Fax: 604-853-8749 | Internet: www.bd-power.com

INSTALLATION:

1: Clean the injector cylinder head bore with special Cummins wire brush tool or equivalent (Fig 5)

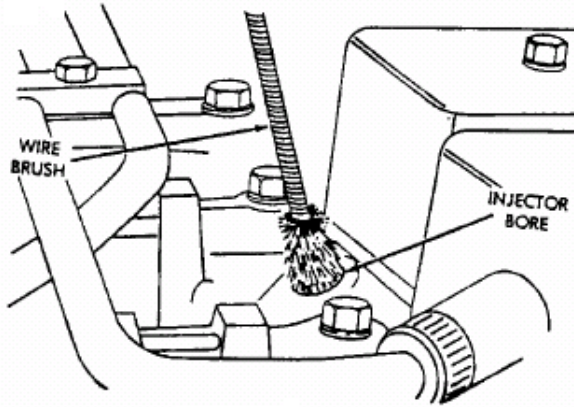

Fig 5: Cleaning Cylinder Head Injector Bore

2: Install a new copper washer on injector (Fig 6)

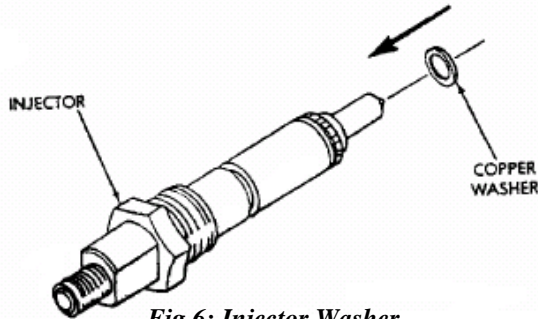

Fig 6: Injector Washer

3: Apply a coating of anti-seize compound to the threads of the injector holddown nut and between the top the nut and injector body (Fig 7).

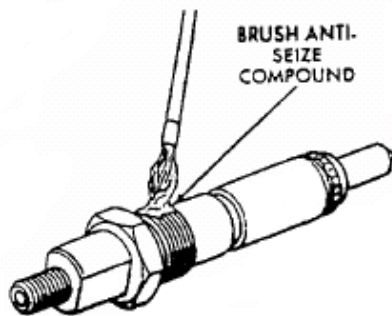

Fig 7: Apply-Seize Compound

4 Install the injector into the cylinder head. Align the tab on the injector to the notch in the cylinder bore (Fig 8). Certain types of injectors **may** have an o-ring located above the holddown nut (Fig 8). After

tightening the injector, push the o-ring into the groove the top of the injector.

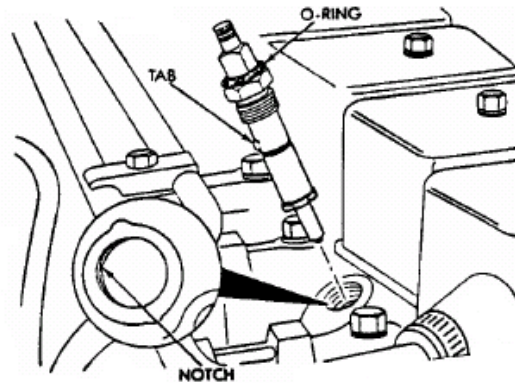

Fig 8: Installing Injector

5: Tighten the injector holddown nut to 60 N-m (44 ft. lbs.) torque.

6: Connect the fuel drain manifold to the injectors.

7: Connect the high-pressure fuel lines.

8. Connect the negative battery cables to both batteries.

9. Bleed the air from the high-pressure lines.

HIGH-PRESSURE FUEL LINES:

All high-pressure fuel lines are of the same length and inside diameter. Correct high-pressure fuel line usage and installation is critical to smooth engine operation.

Caution: The high-pressure fuel lines must be clamped securely in place in the holders. The lines cannot contact each other or other components. Do not attempt to weld high-pressure fuel lines or to repair lines that are damaged. Only use the recommended lines when replacement of high-pressure fuel line is necessary.

BD Engine Brake Inc.

Plant Address: 33541 MacLure Rd. Abbotsford, BC, Canada V2S 7W2

U.S. Shipping Address: 88-446 Harrison St, Sumas, WA 98295 U.S. Mailing Address: P.O. Box 231, Sumas, WA 98295

Phone: 604-853-6096 | Fax: 604-853-8749 | Internet: www.bd-power.com