



DODGE CUMMINS 24Valve INJECTORS **ISB Installation Instructions**

- 1040280 – 40hp Injector Set**
- 1075821 – 50hp *XXX-Pulse* Injector Set**
- 1075822 – 75hp *XXX-Pulse* Injector Set**
- 1075823 – 100hp *XXX-Pulse* Injector Set**
- 1075824 – 125hp *XXX-Pulse* Injector Set**
- 1075825 – 150hp *XXX-Pulse* Injector Set**
- 1075826 – 200hp *XXX-Pulse* Injector Set**

NOTE: On earlier ISB engines with serial number of 56462591 and lower, the injector connector tube may need to be replaced. The new Cummins part #3944833 is stamped on the tube to help in identification. The torque value has been changed to 28ft lbs. The new style injector tubes are available from us should you need them – BD Part # 1040281. Please check your engine serial number before you begin to change your injectors. Thank you for purchasing this quality kit from BD DIESEL PERFORMANCE. Please feel free to contact us if you have any questions.

NOTE: Unless this product has been identified with a CARB # it is only legal in California for racing vehicles which may never be used upon a highway.

BD Engine Brake Inc.

Plant Address: 33541 MacLure Rd. Abbotsford, BC, Canada V2S 7W2

U.S. Shipping Address: 88-446 Harrison St, Sumas, WA 98295 U.S. Mailing Address: P.O. Box 231, Sumas, WA 98295

Phone: 604-853-6096 | Fax: 604-853-8749 | Internet: www.bd-power.com

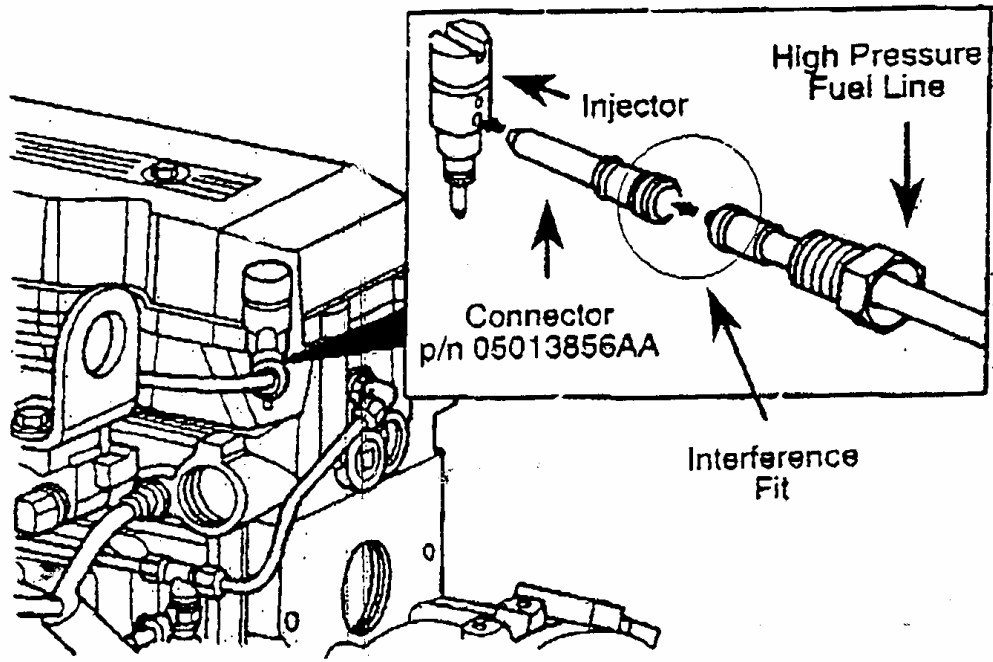
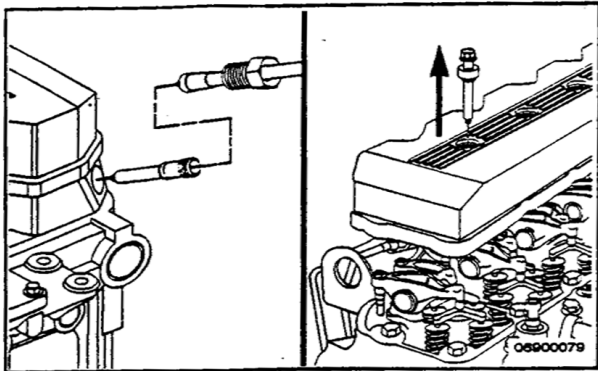

FIGURE 1



Injector (006-026)

Remove (006-026-002)



Remove the rocker lever cover.
Remove the injector supply lines.

NOTE: The fuel connector must be removed before removing the injector or damage to the connector will result.

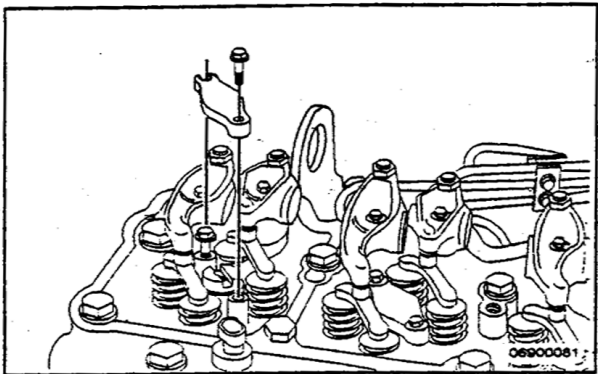

8 mm

Remove the injector hold-down.

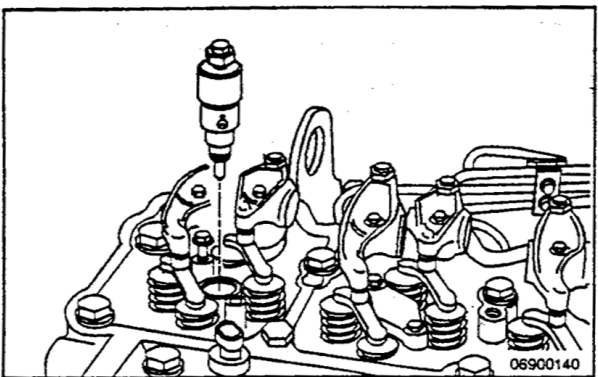

Injector Puller, Part No. 3825156

Using the injector puller, Part No. 3825156, pull the injector out of the head.

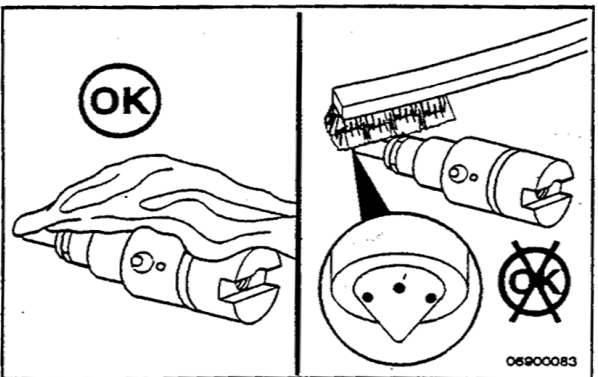

Clean (006-026-006)

Clean injector tip and body with safety solvent and a soft clean rag.

If necessary use a **brass** brush to clean off carbon.

△ CAUTION △

DO NOT use a steel wire brush or glass beading to clean injectors. This will damage the nozzle holes and cause performance problems.

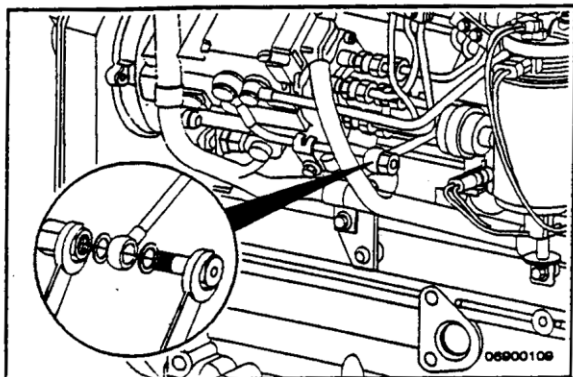

Install (006-044-026)

19 mm



Install new rubber coated sealing washers and fuel return overflow valve.

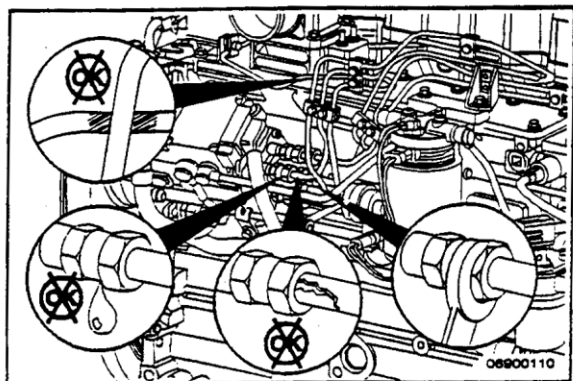

Injector Supply Lines (High Pressure) (006-051)

Initial Check (006-051-001)

17 mm, 19 mm



Visually inspect the lines for cracks, chafing, or leaks. Make sure that the lines are tightened to the proper specification.



17 mm, Fuel Pump Connection

Torque Value: 24 N•m [18 ft-lb]

19 mm, Cylinder Head Connection

Torque Value: 38 N•m [28 ft-lb]

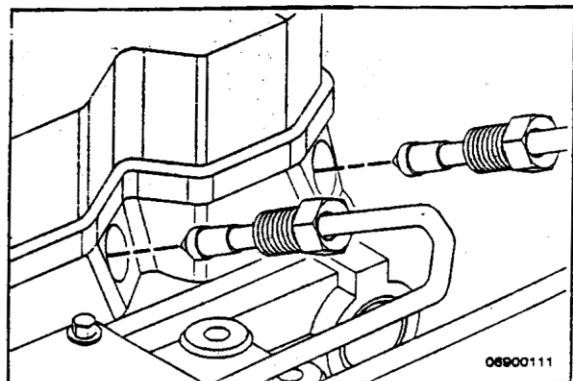

Remove (006-051-002)

19 mm



Disconnect the high pressure fuel lines from the cylinder head.

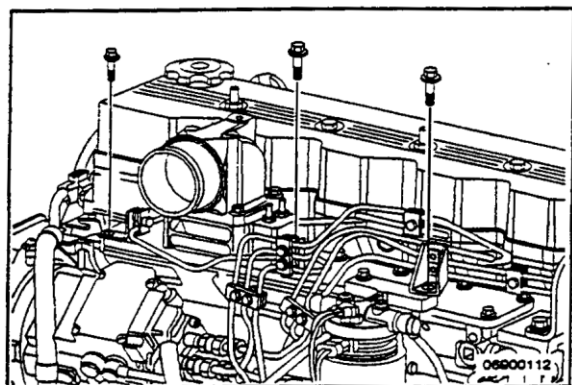

10 mm

Remove the fuel line clamp capscrews from the intake cover.



Install (006-026-026)

8 mm

Place the injector in the head in the proper orientation.
Install the injector hold-down and tighten.

Torque Value: 10 N•m [89 in-lb]

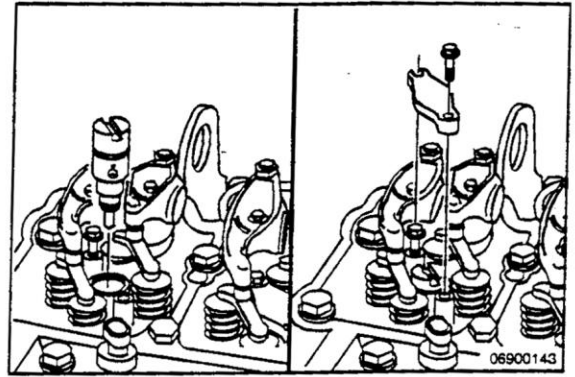

Install the fuel connector.

Install the rocker lever cover.

Install the high pressure fuel lines. Refer to Procedure 006-051-026.

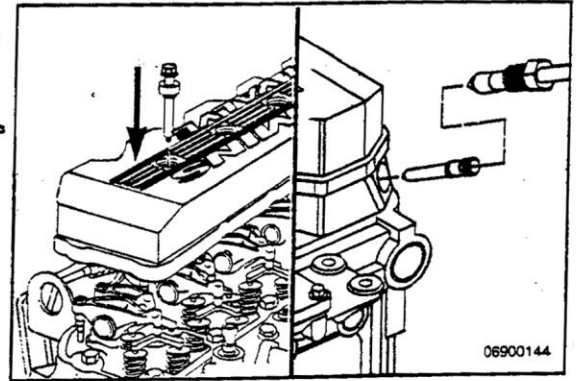

Run the engine and check for leaks.

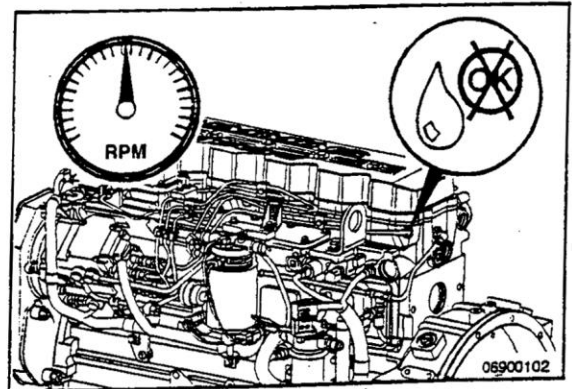

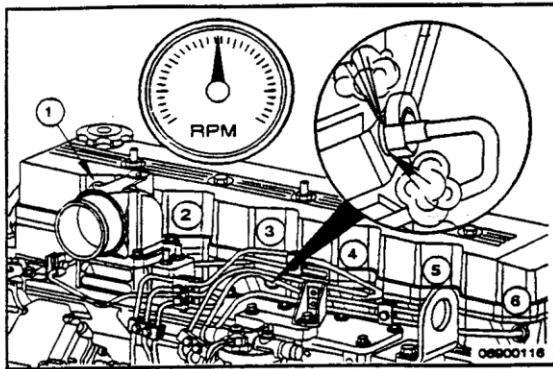

▲ WARNING ▲

Do not bleed a hot engine as this could cause fuel to spill onto a hot exhaust manifold creating a danger of fire.

Operate the engine and vent one line at a time until the engine runs smoothly.

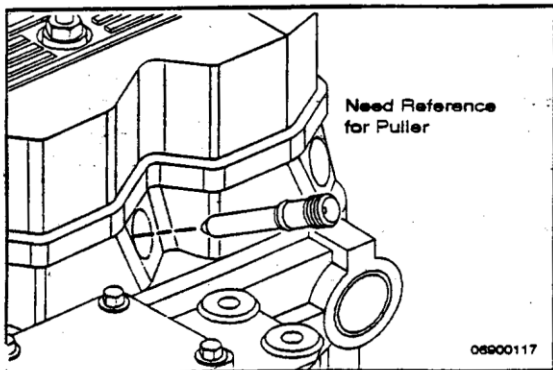

 **Fuel Connector (Head Mounted) (006-052)**

Remove (006-052-002)

 **Fuel Connector Puller, Part No. 3825157**

Install a fuel connector puller, Part No. 3825157.

Remove the fuel-connector out of the cylinder head.

NOTE: When removing the fuel connector from the cylinder head, care must be taken to make sure that the connector O-ring is not damaged.

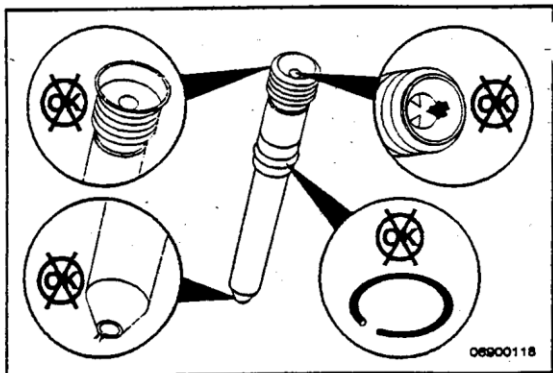

 **Inspect for Reuse (006-052-007)**

Visually inspect the fuel connector. Look for burrs or deformation around the inlet and outlet sides of the connector.

Check the edge filter for signs of plugging or material contamination.

Check the O-ring for tearing or deterioration.

NOTE: It is recommended that the O-ring on the high pressure connector be replaced whenever the connector is removed and installed.

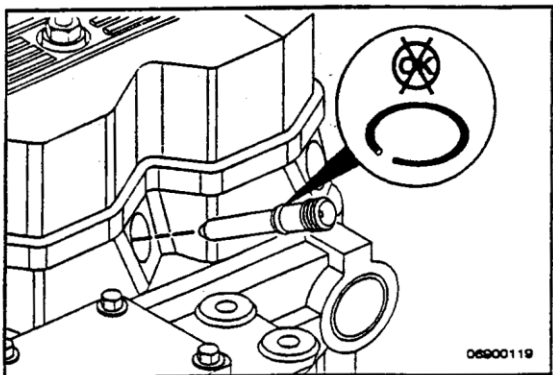

 **Install (006-052-026)**

Carefully push fuel connector into head until it stops against the injector. Be sure not to tear the O-ring as the connector is being installed.

Technical Service Bulletin



SUBJECT:
High Pressure Fuel
Line Service

NO: 14-01-98 Rev. A

GROUP: Vehicle Performance

DATE: Jul. 17, 1998

This bulletin is supplied as technical information only and is not an authorization for repair. No part of this publication may be reproduced, stored in a retrieval system, or transmitted, in any form or by any means, electronic, mechanical, photocopying, recording, or otherwise, without written permission of Chrysler Corporation.

THIS BULLETIN SUPERSEDES TECHNICAL SERVICE BULLETIN 14-01-98 DATED MAR. 6, 1998 WHICH SHOULD BE REMOVED FROM YOUR FILES. THE COMPLETE BULLETIN HAS BEEN REVISED AND INCLUDES A NEW PART NUMBER FOR A FUEL INJECTOR CONNECTOR TUBE THAT CAN BE REUSED.

MODELS:

1998 (BR/BE) Ram Truck

NOTE: THIS INFORMATION APPLIES TO THE 5.9L CUMMINS ELECTRONICALLY INJECTED 24 VALVE DIESEL BUILT PRIOR TO ENGINE SERIAL NUMBER (ESN) 56462592.

DISCUSSION:

Design revisions have been made to the injector connector tube and the new design can be re-torqued multiple times without compromising the seal between the connector tube and high pressure fuel line (Figure 1). The new part number for this connector tube is 05013856AA.

The new connector tube can also be identified by a Cummins part number (3944833) which is stamped on the tube. This identification will help technicians determine if the new tube is on the vehicle or not.

Make sure the "O" ring p/n 05011885AA is replaced when upgrading from the old style to new style connector tubes.

Torque for this connection has changed to 38 Nm (28 ft. lbs.). Using higher torque than specified will cause damage to the injector or connector tube. If the injector or connector tube is damage/deformed, a high pressure fuel leak can result inside the cylinder head. This could cause an engine miss and/or low power.



BD Engine Brake Inc.

Plant Address: 33541 MacLure Rd. Abbotsford, BC, Canada V2S 7W2

U.S. Shipping Address: 88-446 Harrison St, Sumas, WA 98295 U.S. Mailing Address: P.O. Box 231, Sumas, WA 98295

Phone: 604-853-6096 | Fax: 604-853-8749 | Internet: www.bd-power.com