

Supplement

This document covers:

- Special Installation instructions for BedRug products into a Ford F-150 and Ford Super Duty truck with optional Tailgate Step:

1. Install BedRug

in truck box per the main instruction guide.

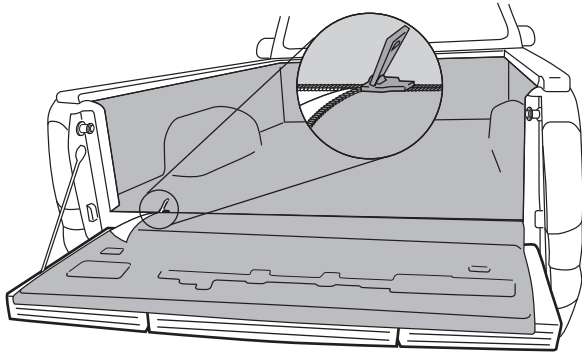

2. Unzip tailgate from BedRug.

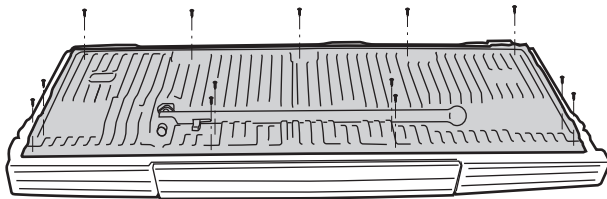

3. Remove fasteners from factory plastic cover:

- F150 — remove (13) screws
- Super Duty — remove (8) screws and (5) plastic “christmas-tree” fasteners.

NOTE: Use a torx bit size T30 to remove screws.

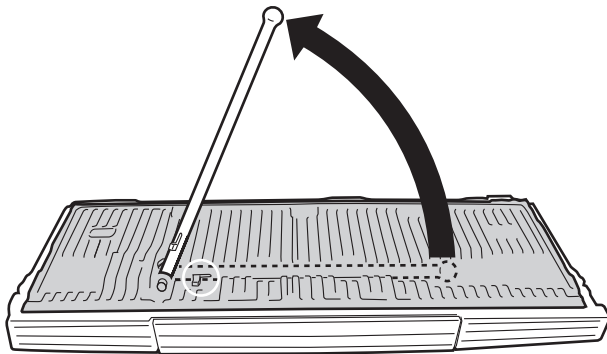

4. Raise bar on step gate — by releasing step bar catch.

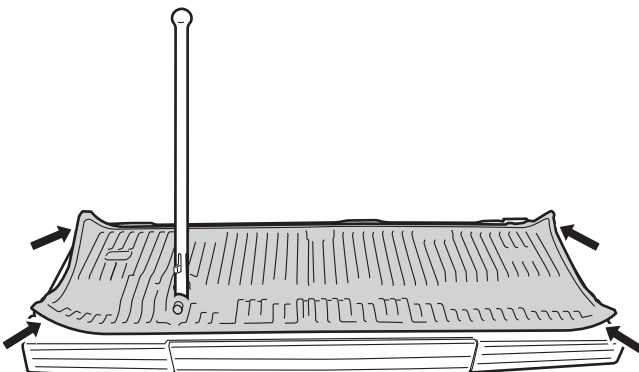

5. Pull plastic cover loose from tailgate.

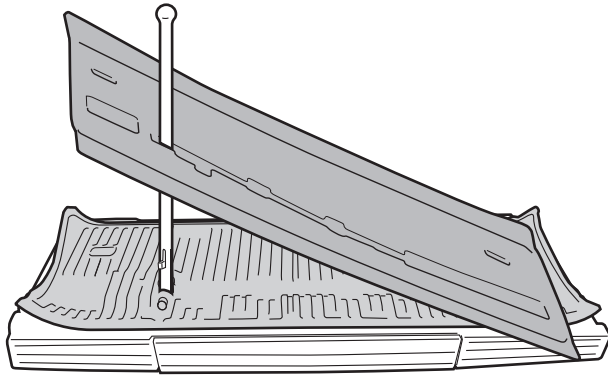

6. **Push BedRug tailgate cover over step handle** at precut slot and position over plastic cover.

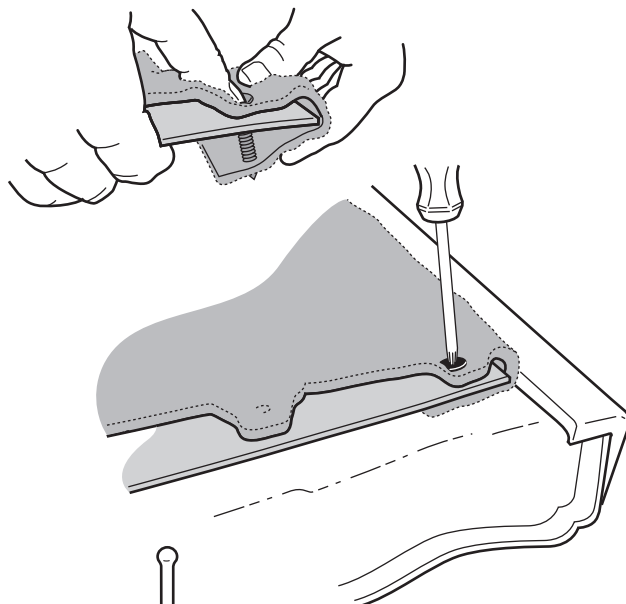

7. **Fold top flap over top edge of plastic cover:**
- F150 — Reinsert four (4) screws to hold BedRug fold in place over plastic cover.
 - Super Duty — Reinsert four (4) screws and two fasteners to hold BedRug fold in place over plastic cover.
8. **Reinstall screws along top edge** keeping BedRug flap tucked tight against edge of plastic cover and below the 45 degree flange at the bottom of the factory tailgate cap.

NOTE: The top flap of the BedRug has extra holes that are intended to be captured by the screws on the underside to ensure flap cannot come loose during use (i.e. when cargo is loaded...etc.)

- It may be somewhat difficult to get plastic cover back over pivot bolt of step handle. Striking the cover down and toward the front of the truck helps reposition the plastic cover and BedRug.

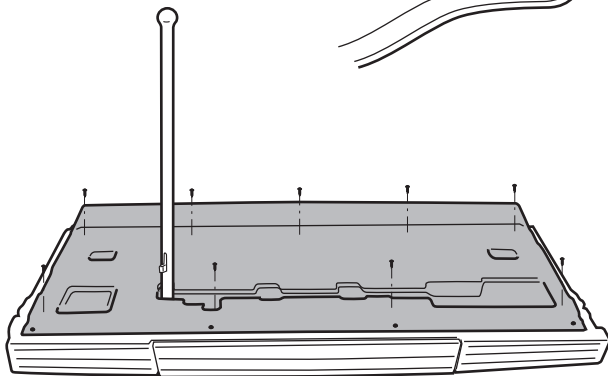

9. **Reinstall all other screws (and/or fasteners)** through prepunched holes in BedRug using a torx bit size T30.

CAUTION: These screws will strip very easily. Do not overtorque. (Specification is 2.7 lb-ft)

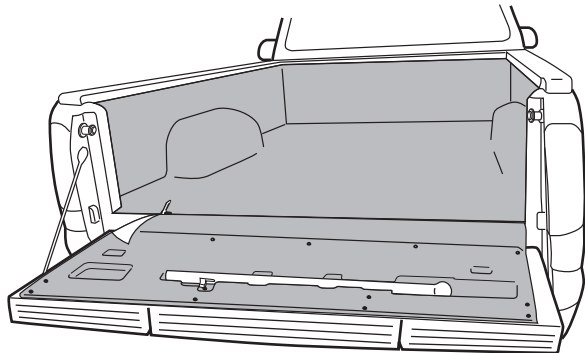

10. **Zip tailgate back to BedRug** — and return step bar to its closed position.