





Installation Instructions ZipRail Tonneau

No Drilling in Truck Bed Required

Vehicle Application:

- Nissan Titan Crew Cab
- 5.5' Short Bed with or without Utilitrack System
- 2004 – 2008
- Part Number: 15175

www.Bestop.com - We're here to help! Visit our web site and click on "[Ask a Question](#)". Click here for more [Truck Accessories by Bestop](#).

INSTALLATION TIME	SKILL LEVEL
 1/2 Hour	 1 - Easy

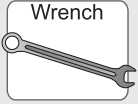
TOOLS	
 Safety Glasses	 Wrench 1/2"

Installation Tips

Before you begin installing this assembly, read all instructions thoroughly.

For a smooth fit:

For ease in installation, the product should be installed at temperatures above 70° F. Below this temperature, the fabric may contract an inch or more, making it difficult to fit to the vehicle. It is normal for fabric to contract and wrinkle when stored in the shipping carton. Within a few days after the installation, the fabric will relax and the wrinkles will disappear.

Wash truck to make sure no dirt or abrasive materials are between your truck's finish and the Tonneau Rail Frame.



CAUTION

Safety glasses should be worn at all times while installing this product.



WARNING

Tonneau cover must be secured at all points when vehicle is moving. A tonneau cover that is unsecured will flap, resulting in damage to the vinyl fabric.

Do not overload bed of truck. Stress on tonneau could result in damage.

ZipRail Tonneau Installation Instructions

Parts List

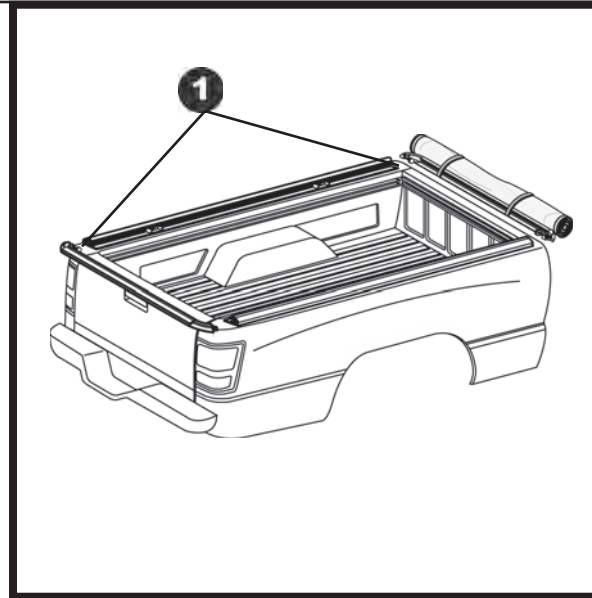
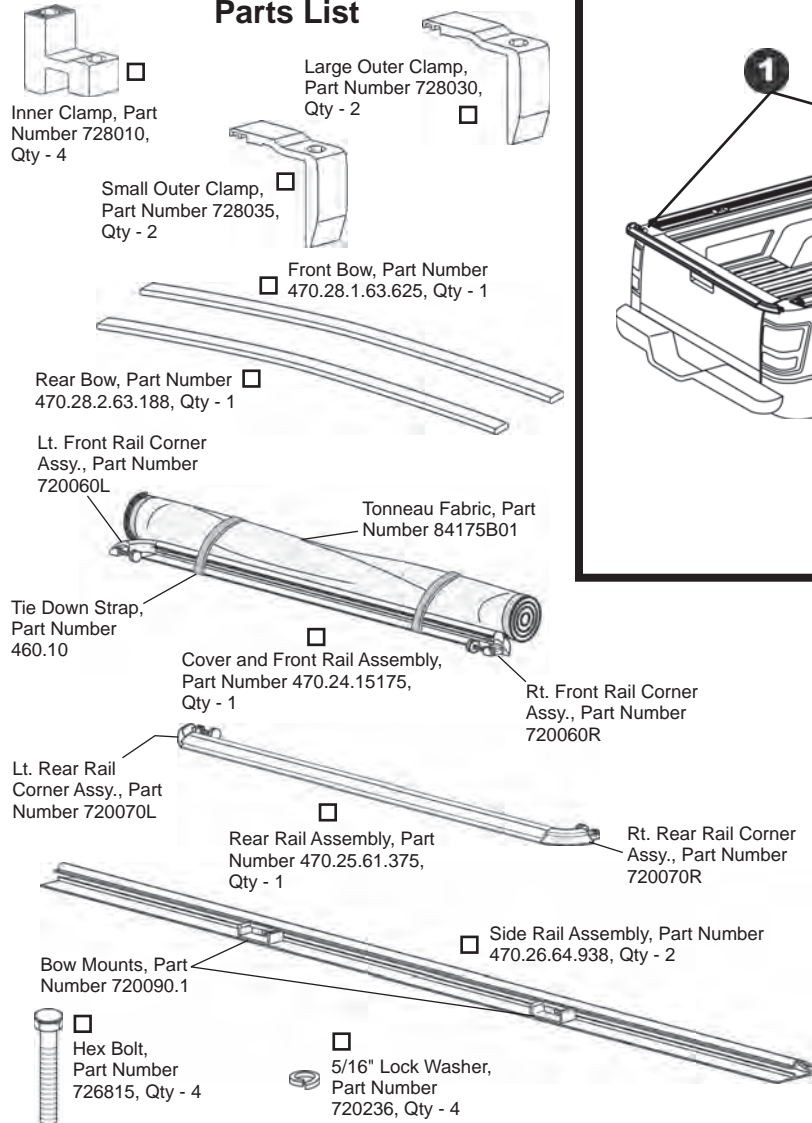

1 Install Rail Assemblies

Locate the Left and Right Side Rails. Remove paper backing and set the Side Rails onto the top of the truck box.

Remove paper backing and set the Front Rail (with cover attached) onto truck. Make sure long ends of Tie Down Straps are to the inside of the truck box. Fasten corners by inserting into Side Rail ends and tightening the thumb screws.

Follow the same procedure to install the Rear Rail.

NOTE If you choose to assemble the frame on a level surface other than the vehicle, use two (2) people to position it on the truck bed to avoid extreme pressure on the corners.

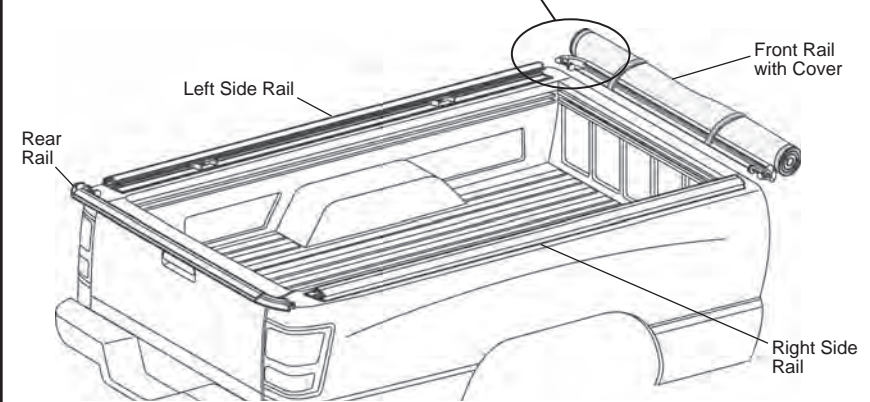
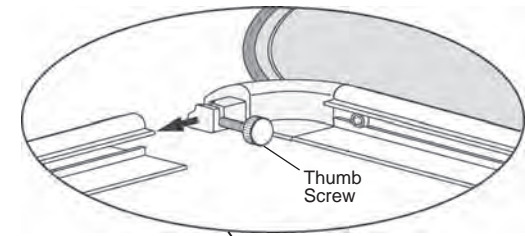

ZipRail Tonneau Installation Instructions

2 Install Bows

Locate the two Bows. Place one end of the Front Bow into one of the front bow mounts then snap the other end into place. Repeat with the Rear Bow. Center the frame assembly side to side and front to back on the bed.

NOTE Only trucks with tapered cargo boxes will have Bows marked FRONT and REAR.

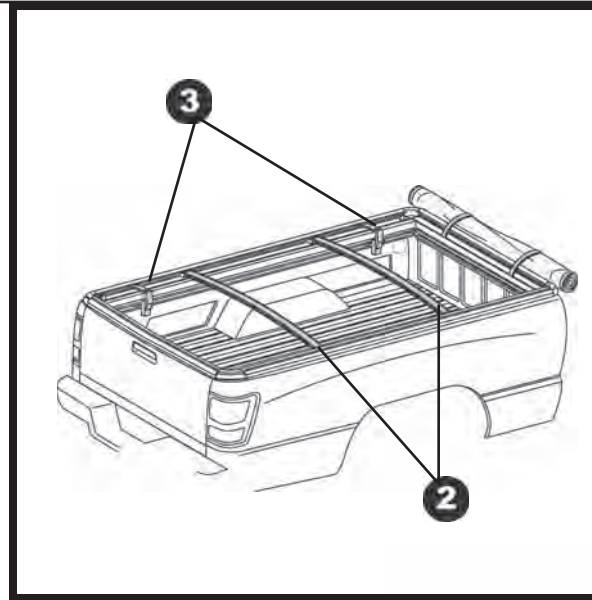
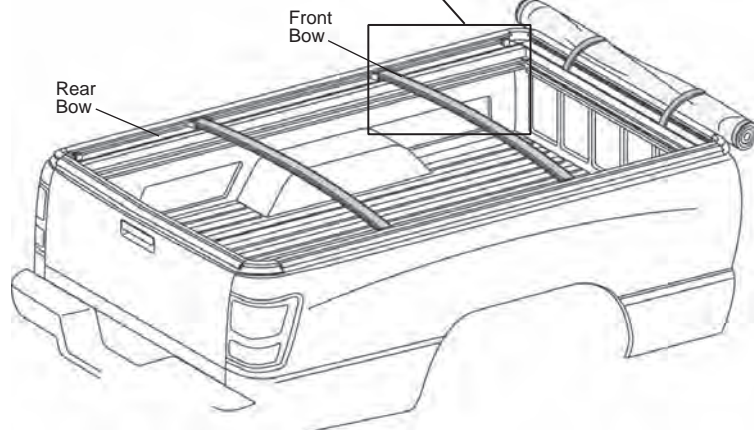
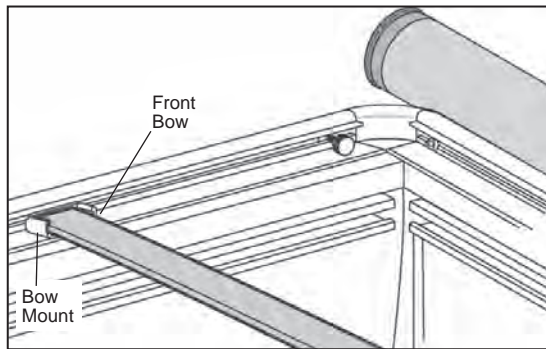

3 Install Inner Clamps with Utilitrack System

Use a Hex Bolt and 5/16" Lock Washer to assemble a Large Outer Clamp with an Inner Clamp. Place it approximately 6" from the front of the bed. Then assemble a Small Outer Clamp with an Inner Clamp and place it 6" from the rear of the bed. Use 1/2" wrench to tighten bolts. Repeat on both sides of the vehicle.

NOTE If power tools are used, be careful not to over tighten Clamps.

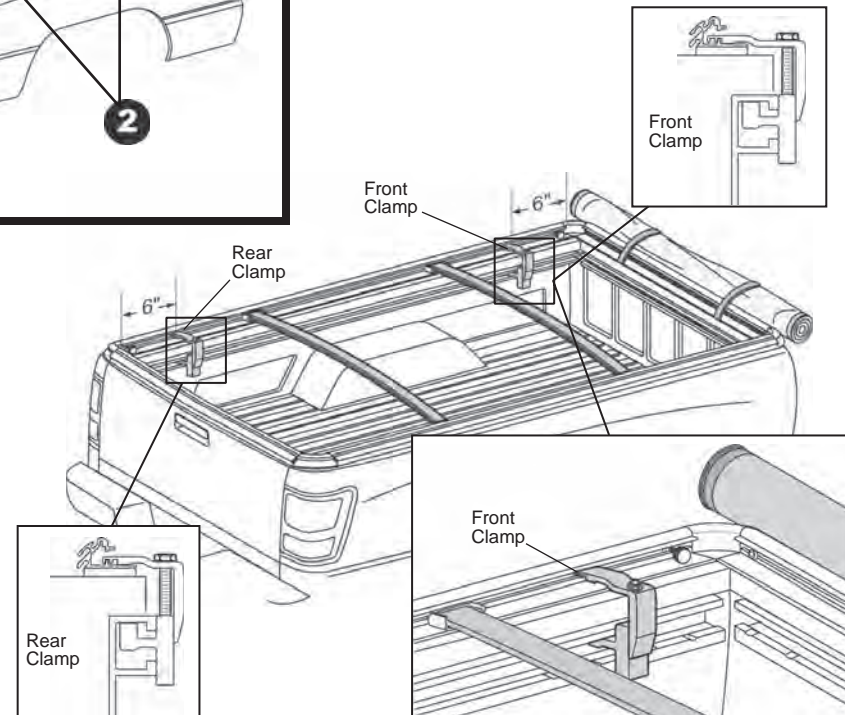

ZipRail Tonneau Installation Instructions

4 Install Inner Clamps without Utilitrack System

Use a Hex Bolt and 5/16" Lock Washer to assemble a Large Outer Clamp with an Inner Clamp. Place it approximately 6" from the front of the bed. Then assemble a Small Outer Clamp with an Inner Clamp and place it 6" from the rear of the bed. Use 1/2" wrench to tighten bolts. Repeat on both sides of the vehicle.

NOTE If power tools are used, be careful not to over tighten Clamps.

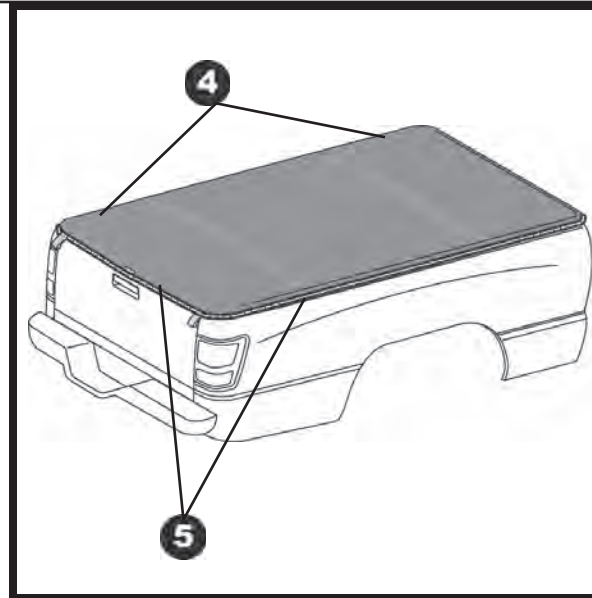
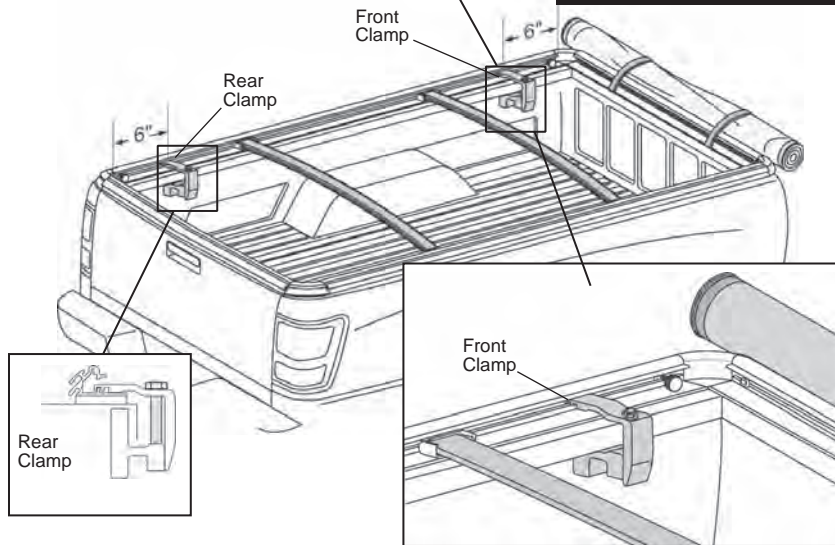
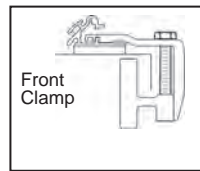

5 Secure the Fabric

Make sure the inside edge of the Front Rail is aligned with the inside edge of the bed and that the Rail Assembly is centered from side to side on the vehicle.

Check that the front strip on the Tonneau Fabric is centered in the Front Rail. If not slide the strip in the rail until it is centered.

The plastic strips along the three sides of the vinyl cover fit into the grooves in the rail assembly.

Pull the cover over the bows to the rear of the truck. Center the fabric tag above the tailgate latch and begin inserting the rear plastic strip into the groove working from the center out to each rear corner. Use one hand to insert and the other to guide the plastic into the groove.

Start at either the front or rear corner to insert the side plastic strip into the groove. Work to the opposite corner. Repeat on both sides.

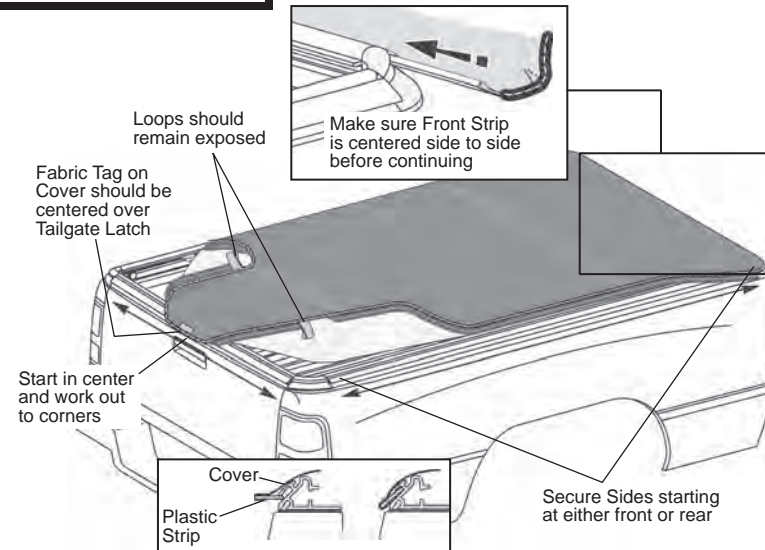

ZipRail Tonneau Installation Instructions

6 Removing Cover

To remove cover: Use the loops at the Right or Left rear corner to ease the plastic strip out of the rail by pulling DOWN and OUT. Then peel the plastic strip out of the remainder of the rear rail. Pull DOWN and OUT on the vinyl fabric to remove the plastic strips from the sides of the rail assembly.

Roll cover toward cab of truck. Use Hook & Loop straps attached to front of rail to secure cover.

To fasten cover, repeat installation step 4.

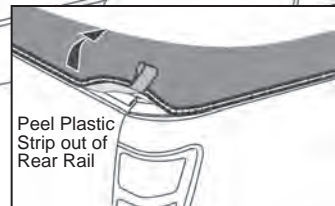
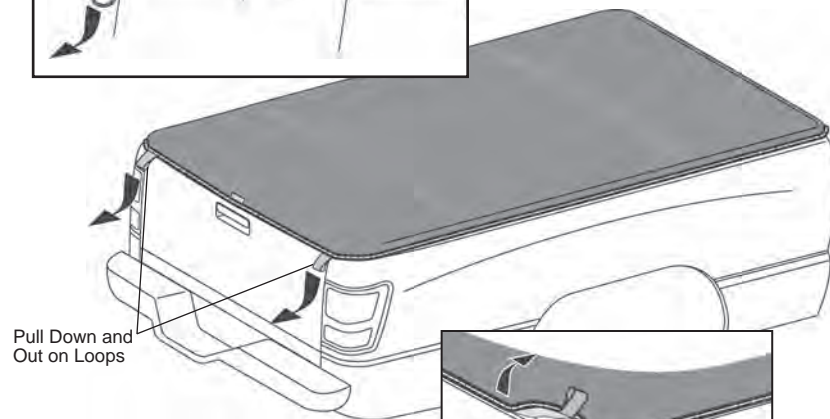
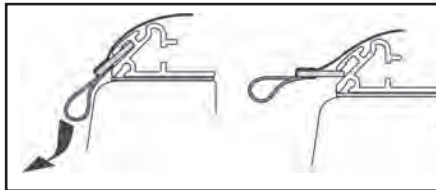
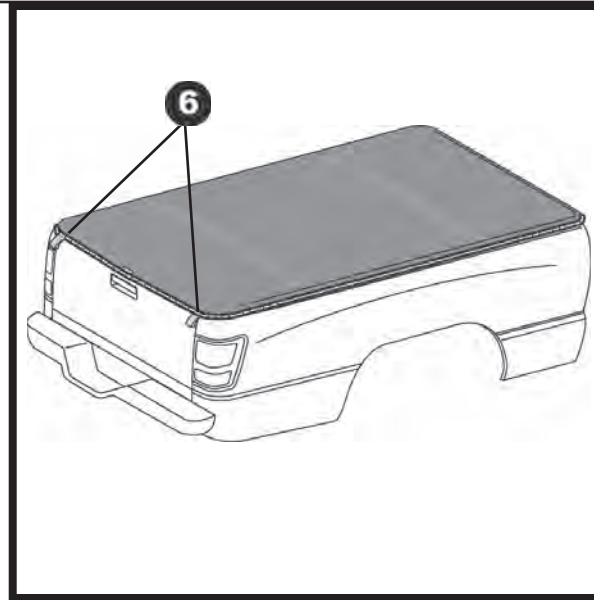

ZipRail Tonneau Installation Instructions

Care and Maintenance of your Bestop Product

Your Bestop product is made of the finest materials available. To keep it looking new and for the maximum possible wear, it will need periodic cleaning and maintenance.

Washing: The fabric should be washed often using soap, warm water and a soft bristle brush. Rinse with clear water to remove all traces of soap or use Bestop-recommended Bestop Cleaner and Bestop Protectant. Bestop Cleaner and Bestop Protectant are specially formulated to provide a total cleaning and protection system. Bestop Cleaner will not harm vehicle finish, is biodegradable and environmentally friendly. Bestop Protectant protects against UV-fading, cracking and hardening.

Water: Seeping through at the seams may be stopped by applying 3-M Scotchgard® on the inside of the seams. Rips in the fabric may be repaired with Bondex® iron on patches. Iron the patches to the Inside of the top, carefully following the Bondex® instructions.

Snaps: Keep snaps cleaned and lubricated to help prevent snaps from sticking to the studs. If a snap does become stuck to a stud, use a screwdriver and GENTLY pry apart to prevent permanent damage to the snap or the fabric.

BESTOP TONNEAU COVERS LIMITED LIFETIME WARRANTY

What's covered?

All defects in materials or workmanship on Bestop Tonneau Covers for pick-up truck beds. This warranty does not apply to other Bestop products.

This warranty and any implied warranties including merchantability and fitness for a particular purpose, lasts as long as the original retail purchaser owns the vehicle upon which the tonneau cover is installed. The warranty expires should the product be removed from the original vehicle or if the original vehicle is transferred to another owner. This warranty is not transferable.

What Bestop will do.

During the warranty period as written above, Bestop shall, at its option, either repair or replace any defective product at no charge. Bestop will not pay for labor charges associated with installation or removal of the product. Should a specific product be discontinued, Bestop may, at its option replace the discontinued product with a current product or like product.

The Warranty does not cover:

Damage, defect, or malfunction caused by misuse, abuse, accident, fire, improper installation, modification, improper or inadequate maintenance, or hazards, or acts of God. Incidental or consequential damages are not covered under this warranty. Some states do not allow exclusion or limitation, so this may not apply to you. This warranty gives you specific legal rights, and you may have other rights which vary from state to state.

Warranty Service:

Retain your proof of purchase. Proof of purchase must accompany any warranty claim. A defective item should be returned to the place of purchase. Bestop's Customer Service may be contacted for help determining whether a product is defective. Bestop Customer Service may be reached a 1-800-845-3567, or via e-mail at cs@bestop.com.



For further information or request for warranty work, please contact:

Bestop Inc., Customer Service

Toll-Free: (800)845-3567

Main: (303)465-1755

E-mail: csbestop@Bestop.com

Website: www.Bestop.com