





Installation Instructions Hardtop







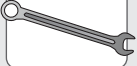

Application:

- Jeep Wrangler Unlimited
2007 and Newer
Part Number: 41611

- Jeep Wrangler
2007 and Newer
Part Number: 41610

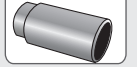
www.Bestop.com - We're here to help! Visit our web site and click on ["Ask a Question"](#). Click here for more [Jeep Accessories by Bestop](#).

INSTALLATION TIME	SKILL LEVEL
 2 Hours	 3 - Moderately Hard

TOOLS			
 Wrench 1/2" and 7/16"	 Tape Measure	 Phillips Screwdriver	 Ratchet
 Socket 1/2"	 Flat-Head Screwdriver	 Utility Knife	 Safety Glasses



 **CAUTION** Safety glasses should be worn at all times while installing this product.

 **CAUTION** To ensure your hardtop fits properly, you must be able to adjust your Jeep's windshield, door hinge and tailgate surfaces. Failure to make proper adjustments may result in leaks or wind noise. Read all installation instructions carefully before purchasing a hardtop. Installation by a professional installer is highly recommended. Attempting to install this top without the ability to adjust your Jeep may void your hardtop warranty.

 **WARNING** This product is designed primarily to enhance the appearance of the vehicle and to shield the occupants from ordinary weather conditions. Do not rely in any way on the components of this product to contain occupants within the vehicle, or to protect against injury or death in the event of an accident. This product will not protect the occupants from falling objects. Never operate the vehicle in excess of manufacturer's specifications.

WEAR SEAT BELTS AT ALL TIMES

Read and follow, precisely, all installation instructions provided when installing product. Failure to do so may result in a poor fit and could place occupants of the vehicle in a potentially dangerous situation.

Hardtop Installation Instructions

426.03 Parts List and Hardware Identification

Cockpit Cover	Qty - 1
Rear Shell	Qty - 1

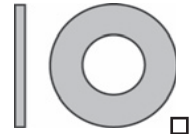

5/16" Fender Washer, Qty - 12
Part Number 475.64

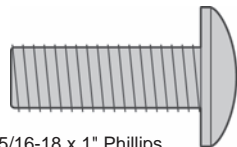

5/16-18 x 1" Phillips Head Bolt, Qty - 6
Part Number 475.65

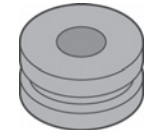

Rubber Spacer, Qty - 2
Part Number 475.68



Tailgate Guard, Part Number 426.07 Qty -1

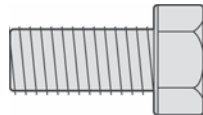

Hex Bolt, Qty - 2
Part number 475.70



M8 Knob, Qty - 4
Part Number 475.72



M8 Threaded Stud, Qty - 4
Part number 475.71

Wire Harness Kit, Part Number 426.40, Qty - 1

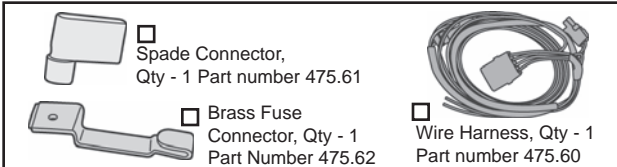

1 Remove Soft Top

If there is a soft top installed on your vehicle, you must remove it.

2 Unpacking the 2 Piece Hard Top

Save all packing materials.

Unscrew the Rear Shell and Cockpit Cover from the pallet and remove them.

Remove all hardware and weatherproof seals from the box with doors and check them against the Parts List to ensure that you have received all the necessary parts.

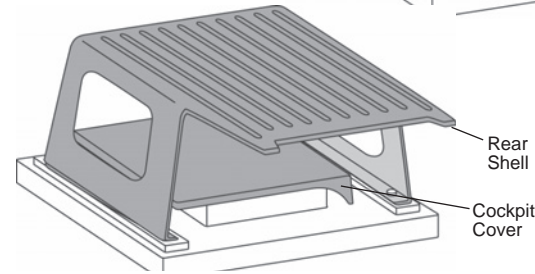
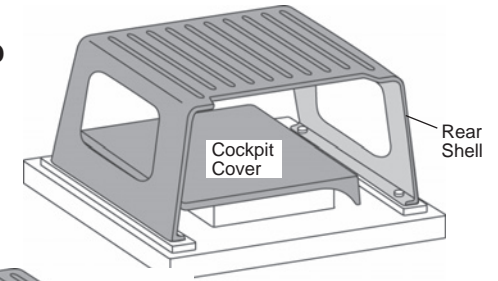

3 Remove Tailgate Retainers

Roll the Tailgate Retainers on each side of the tailgate opening until they release from the vehicle body.

NOTE There is a rubber Mocket Seal on top of the belt rail near the tailgate opening behind the door openings. Make sure this seal remains in place on both sides of the vehicle.

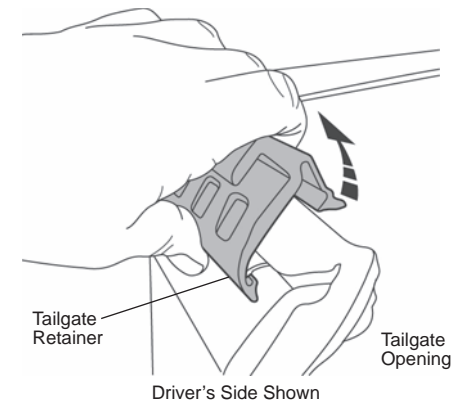
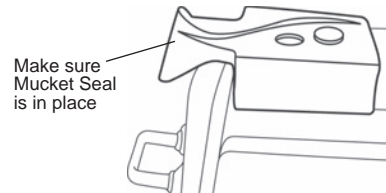

Hardtop Installation Instructions



CAUTION

Two people are required to install the top on the vehicle.

4 Install Rear Shell

Lift the Rear Shell onto the vehicle and line up the holes in the shell with the mounting holes in the body.

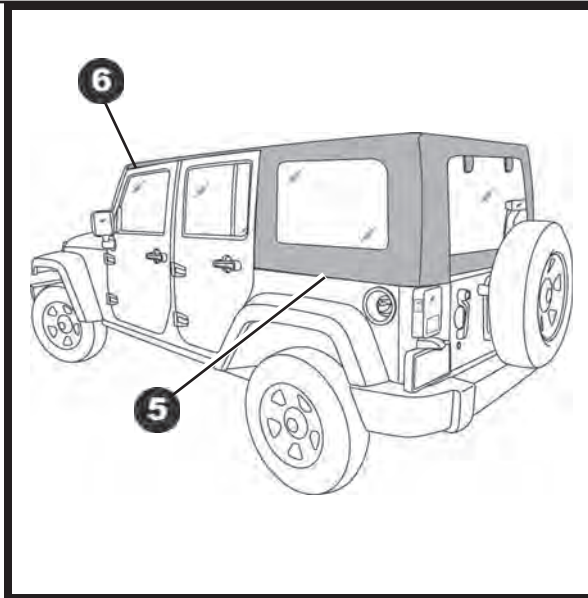
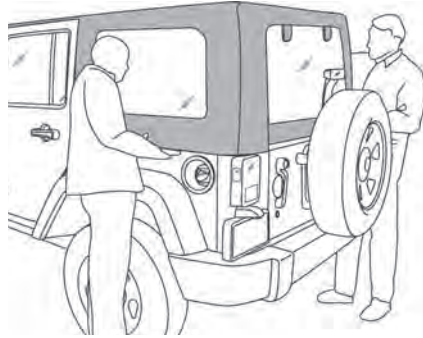

6 Secure Rear Shell – 4 Door Vehicle

Install six (6) 5/16"-18 x 1" Bolts, twelve (12) 5/16" Fender Washers and six (6) 5/16-18 Nylock Nuts through the holes in the beltline angle.

Install a Hex Bolt in the holes in each front corner of the shell with a Rubber Spacer between the top and the body.

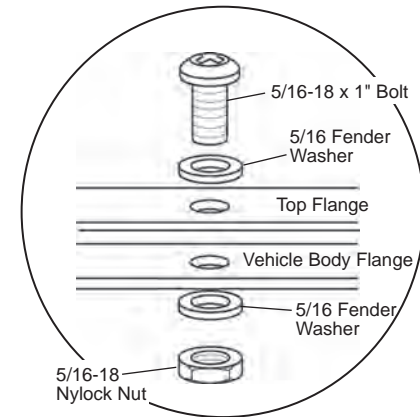

5 Secure Rear Shell – 2 Door Vehicle

Install six (6) 5/16"-18 x 1" Bolts, twelve (12) 5/16" Fender Washers and six (6) 5/16-18 Nylock Nuts through the holes in the beltline angle.

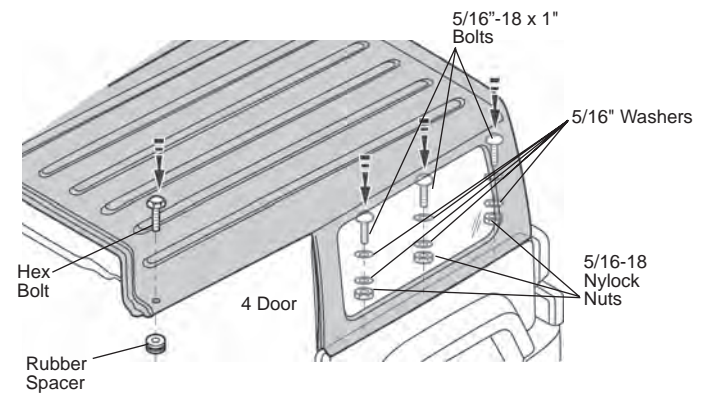
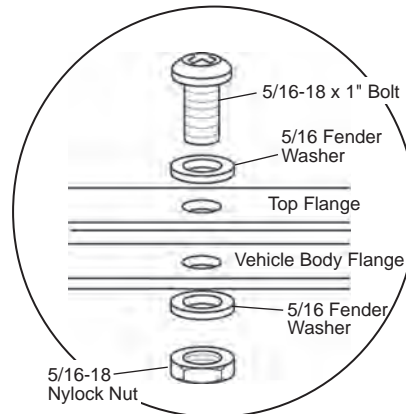
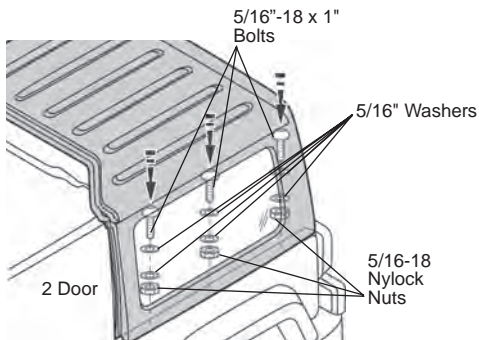

Hardtop Installation Instructions

7 Install Threaded Studs in Cockpit Cover

Use a flat screwdriver to install a Threaded Stud in the four (4) locations in the Cockpit Cover.

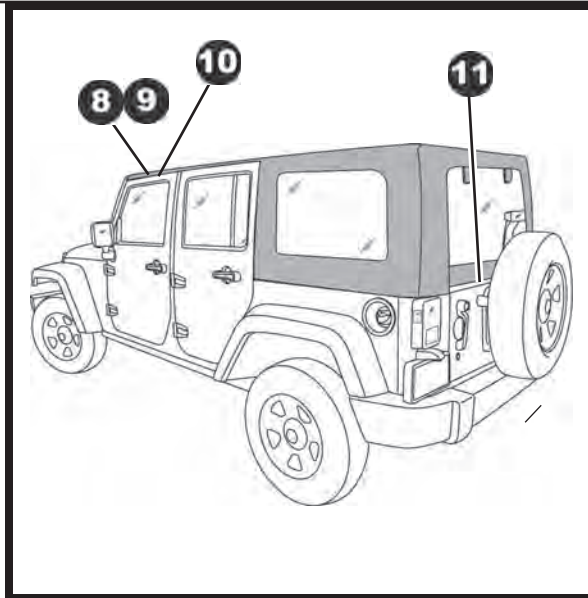
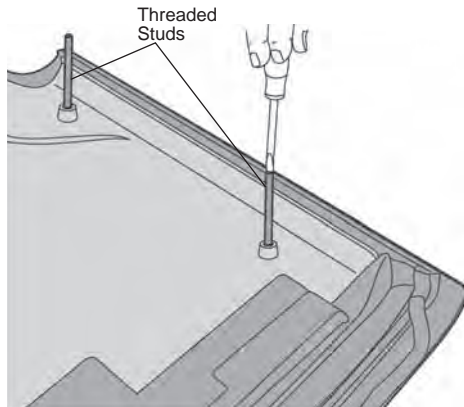

9 Install Cockpit Cover

Place the Cockpit Cover on the vehicle, rear edge first, then lay the front edge down on the windshield. You may need to pull the cover toward the rear to engage the seal. Slip the Threaded Studs through the holes in the sport bar. Install the Turn Knobs on the Studs.

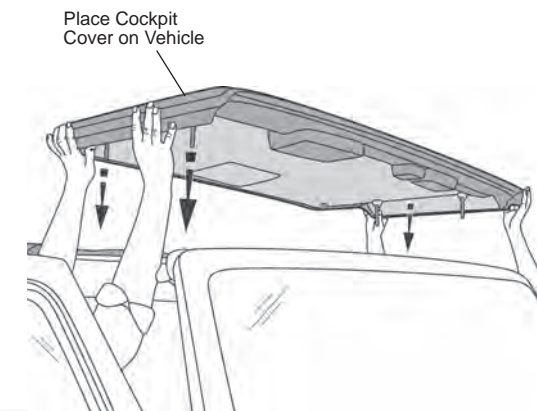

8 Cut Hole in Sport Bar Cover if Needed

If your vehicle does not have openings in the sport bar cover above the doors, you will need to cut holes in the cover to access the holes in the sport bar. If this is the case, press on the cover to locate the holes in the bar. Use a utility knife to cut a 5/16" hole in the cover.

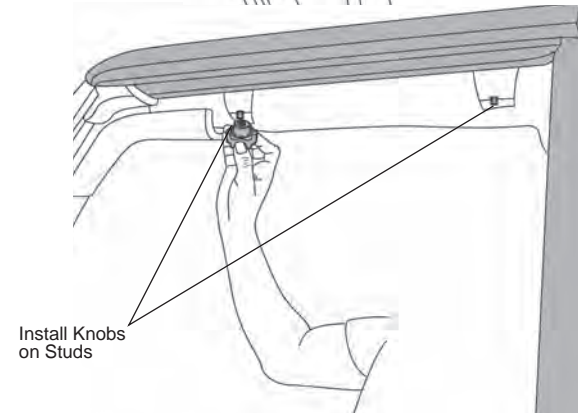
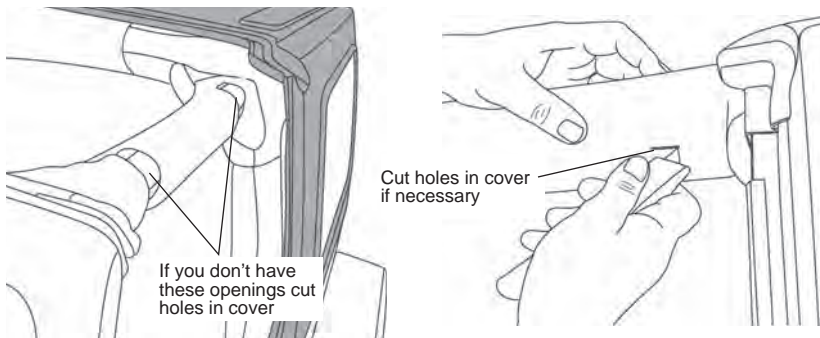

Hardtop Installation Instructions

10 Full Door Alignment Check

If you have full doors, they must sit at least 1/4" inside the rain gutter on the vehicle in order to ensure a tight seal and to prevent leaking.

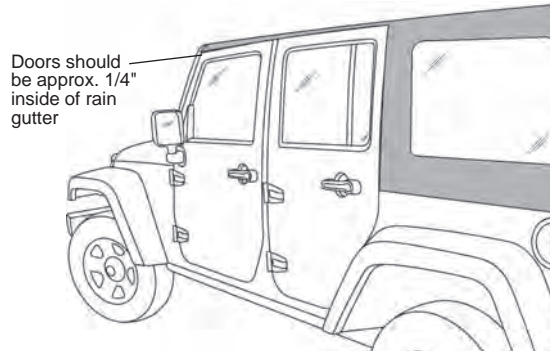

11 Install Tailgate Guard

Press the Tailgate Guard onto the rear edge of the Tailgate. Work across from the right side of the vehicle to the left.

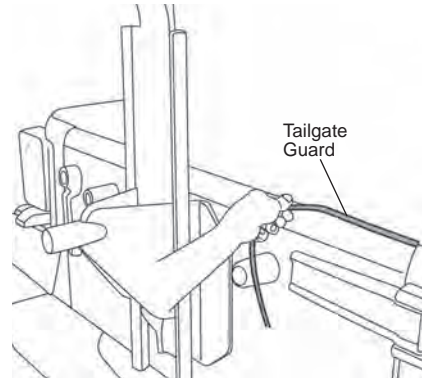

12 Check Rear Window Adjustment

The rear window alignment may have shifted during shipping. If its necessary to realign it, use a phillips screwdriver and 7/16" wrench to loosen the screws. Center the window and retighten the screws.

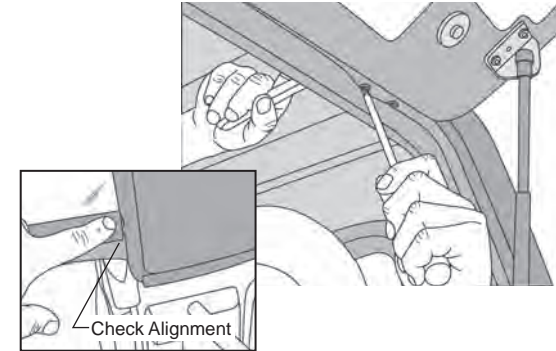

CAUTION

Disconnect the Quick Disconnect before removing the Cockpit Cover.

13 Install Wiring Harness

Locate the Wiring Harness in the parts kit. The leads are marked "Rear Defrost", "Lights", and "Ground".

Connect the Wiring Harness to the Quick Disconnect tting under the carpet in the Cockpit Cover.

NOTE The Defrost and Light Switches in the Cockpit Cover are pre-wired. The yellow switch turns on the Defroster.

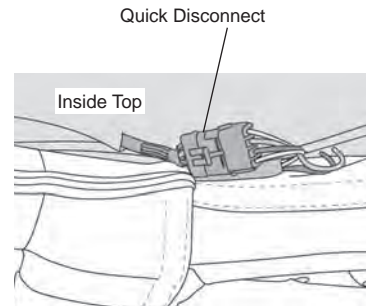

14 Thread Wiring Harness under Sport Bar Cover

Unzip the sport bar cover and route the Wiring Harness along the sport bar toward the windshield.

Zip the sport bar cover closed.

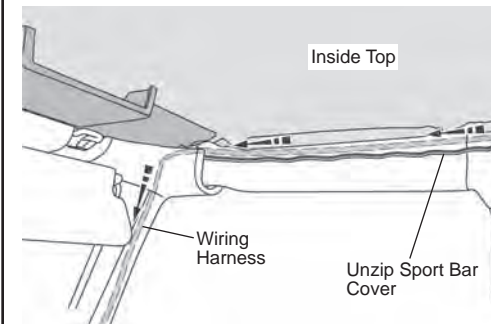

Hardtop Installation Instructions

15 Remove Passenger Sun Visor

Use a phillips screwdriver to remove the two screws that secure the passenger side Sun Visor. Set the visor and screws aside to be reinstalled later.

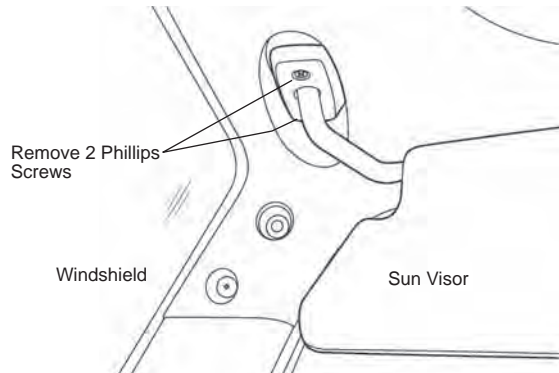

16 Remove Molded Corner Panel and A-Pillar Panel

Remove the push fastener that holds the Molded Corner Panel in place. Set the fastener and panel aside to be reused later. Then remove the A-Pillar Panel.

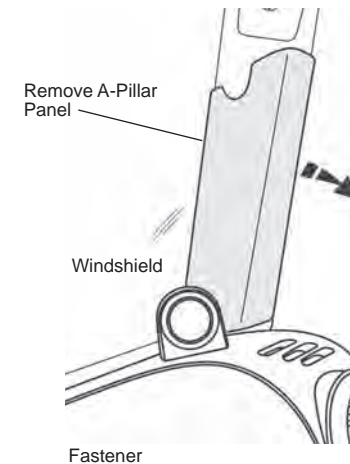
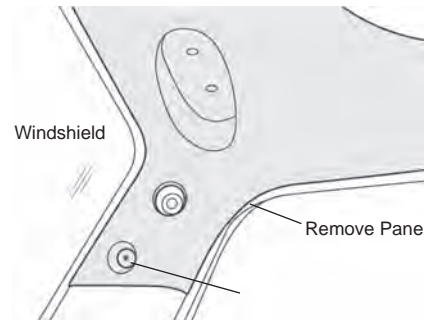

17 Thread Wiring Harness through Dash

Pull the panel along the side of the dash away.

Route the Wiring Harness from the sport bar down along the A-Pillar and under the dash into the footwell.

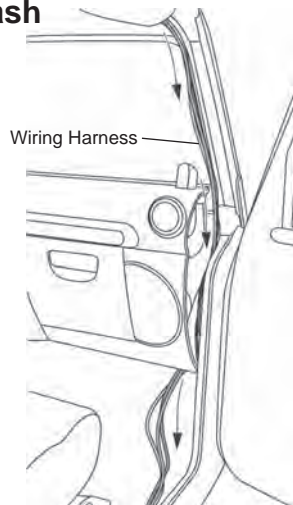

18 Thread Wiring Harness through Fire Wall

Continue to route the Wiring Harness along the route of the other bundled wires through grommet in the firewall and into the engine compartment.

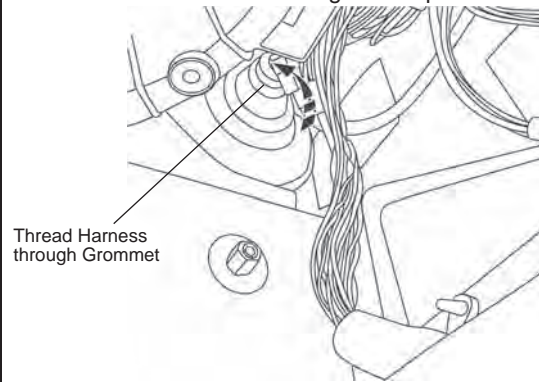

19 Install Spade Connector

Press the Spade Connector on the end of the power line on the Wiring Harness.

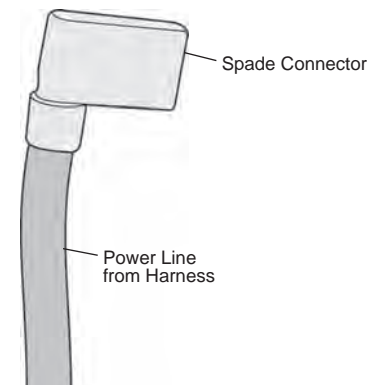

Hardtop Installation Instructions

! WARNING Disconnect the battery before installing the Fuse Connector.

20 Install Brass Fuse Connector

Route the Wiring Harness along the engine compartment to the accessory connection point for power source when the key is on (Fuse CB1 Ignition off accessory power) in the fuse box. Install the Brass Fuse Connector. Connect the Spade Connector to the Brass Fuse Connector.

Connect the ground on the Wiring Harness to the ground off the battery.

Reconnect the battery.

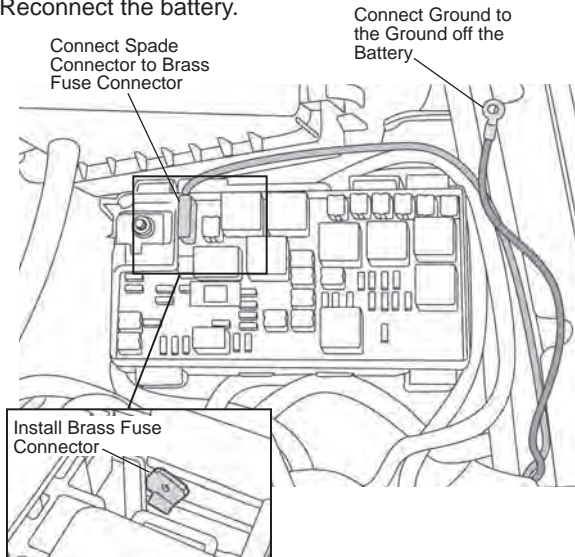

21 Reinstall Moldings and Sun Visor

Tuck the Wiring Harness in and reinstall the panel along the side of the dash. Then reinstall the A-Pillar Molding and the Molded Corner Panel. Reinstall the Sun Visor.

22 Hardtop Configurations

Hardtop without Cockpit Cover



Hardtop with Roof Rack (Sold Separately Part Number 41400 or 41101)



Hardtop with Rear Shell Removed



Hardtop with Cockpit Cover Stored on Roof Rack (Sold Separately)



Hardtop Installation Instructions

LIMITED WARRANTY

We warrant our product to be free from defects in material and workmanship, for the terms specified below, provided there has been normal use and proper maintenance. This warranty applies to the original purchaser only. All remedies under this warranty are limited to the repair or replacement of any item or items found by the factory to be defective within the time period specified. If you have a warranty claim, first you must call our factory at the number below for instructions. You must retain proof of purchase and submit a copy with any items returned for warranty work. Upon completion of warranty work, if any, we will return the repaired or replaced item or items to you freight prepaid. Damage to our products caused by accidents, fire, vandalism, negligence, misinstallation, misuse, Acts of God, or by defective parts not manufactured by us, is not covered under this warranty.

THE WARRANTY TIME PERIOD IS AS FOLLOWS FOR REPLACE-A-TOP™, SAILCLOTH REPLACE-A-TOP™, SUPERTOP®, SUPERTOP® REPLACEMENT SKINS, SUNRIDER®, AND TIGERTOP®: TWO YEARS FROM DATE OF PURCHASE.

THE WARRANTY TIME PERIOD IS AS FOLLOWS FOR ALL OTHER "SOFT GOODS" MANUFACTURED BY OUR COMPANY (USING PRIMARILY VINYL, PLASTICS, AND/OR FOAM): ONE YEAR FROM DATE OF PURCHASE.

THE WARRANTY TIME PERIOD IS AS FOLLOWS FOR ALL OTHER "HARD GOODS" MANUFACTURED BY OUR COMPANY (USING PRIMARILY METALS, PLASTICS, AND/OR FIBERGLASS): ONE YEAR FROM DATE OF PURCHASE.

ANY IMPLIED WARRANTIES OF MERCHANTABILITY AND/OR FITNESS FOR A PARTICULAR PURPOSE CREATED HEREBY ARE LIMITED IN DURATION TO THE SAME DURATION AND SCOPE AS THE EXPRESS WRITTEN WARRANTY. OUR COMPANY SHALL NOT BE LIABLE FOR ANY INCIDENTAL OR CONSEQUENTIAL DAMAGE.

Some states do not allow limitations on how long an implied warranty lasts, or the exclusion or limitation of incidental or consequential damages, so the above limitations or exclusions may not apply to you. This warranty gives you specific legal rights, and you may also have other rights which vary from state to state.



For further information or request for warranty work, please contact:
Bestop Inc., Customer Service
Toll-Free: (800)845-3567
Main: (303)465-1755
E-mail: csbestop@Bestop.com
Website: www.Bestop.com