



# Installation Instructions

## HOSS™ Hardtop Organized Storage System

### Application:

- Hard Top and Doors Storage System  
Part Number: 42801

www.bestop.com - We're here to help! Visit our web site and click on "Ask a Question"

INSTALLATION TIME	SKILL LEVEL
 2 Hours	 2 - Moderately Easy

TOOLS			
 Wrench 7/16", 3/4" and 9/16"	 Tape Measure	 Phillips Screwdriver	 Safety Glasses

**WARNING** The Top Cart is designed to hold only the 1 piece or 2 piece Jeep® Hardtop.



HOSS™ Cover, fabric Window Roll and Tool Caddy sold separately (42802 for 1-Piece Hardtop and 42803 for 2-Piece Hardtop).

# HOSS™ Top Cart Installation Instructions

## Parts List and Hardware Identification

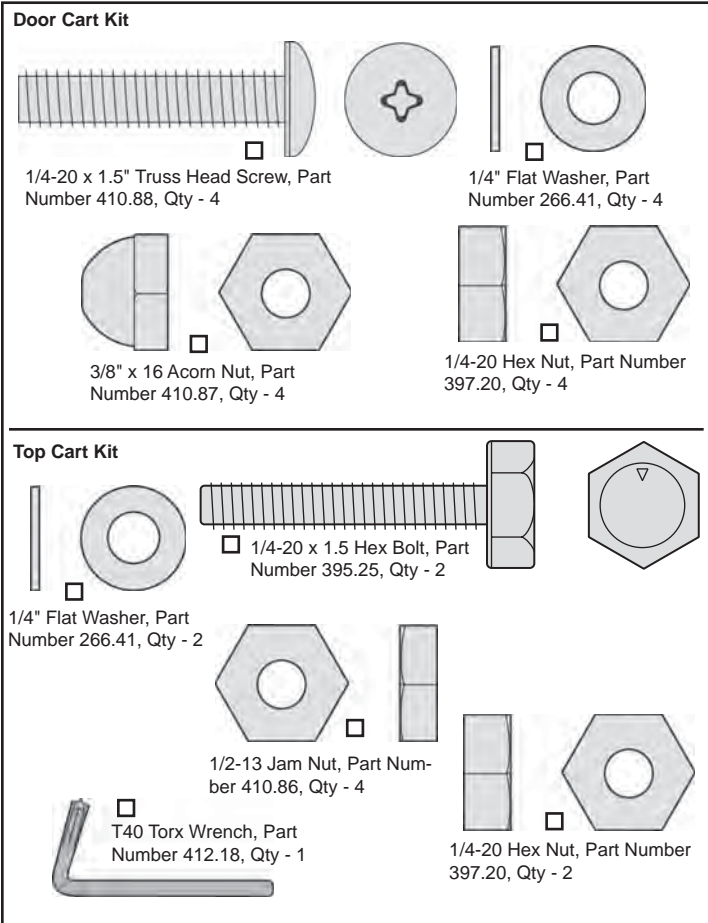
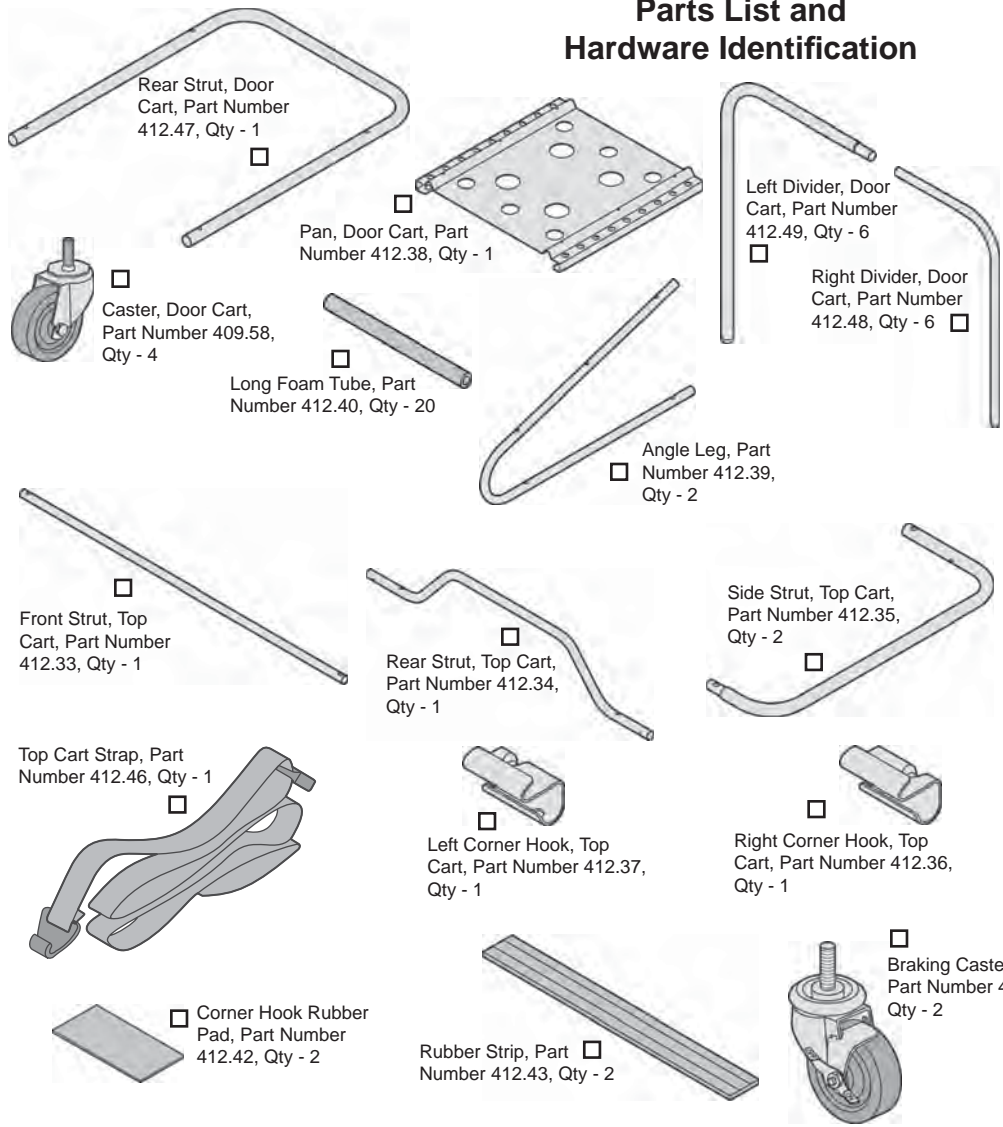

# HOSS™ Top Cart Installation Instructions

## 1 Install Long Foam Tubes on Front Strut - Top Cart

Locate the Top Cart Front Strut and two (2) of the Long Foam Tubes in the parts kit. Slide the sleeves over the strut and center them with a 2" space between them.

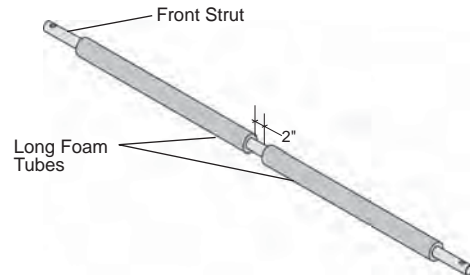

## 2 Install Short Foam Tubes on Rear Strut - Top Cart

Locate the Top Cart Rear Strut and the two Short Foam Tubes in the parts kit. Slide the sleeves onto the strut and center them with a 2" space between them.

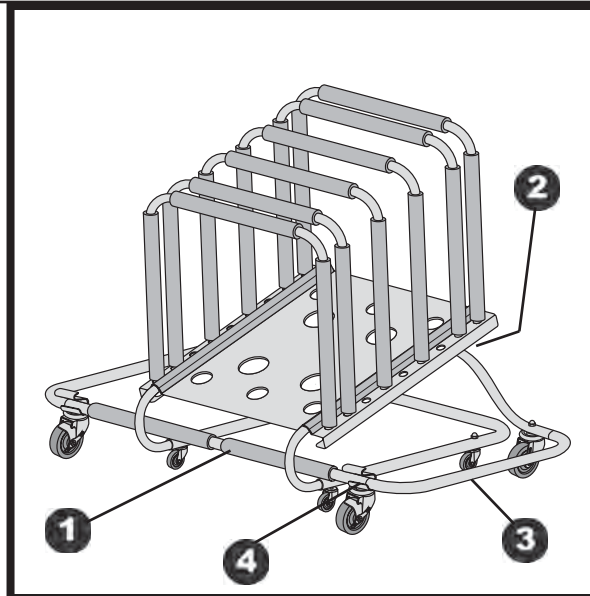
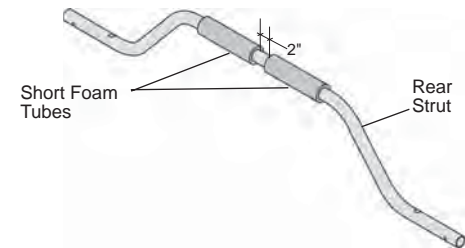

## 3 Assemble Top Cart Struts

Orient the Front, Rear and Side Struts to each other. Slide them together and line up all the holes.

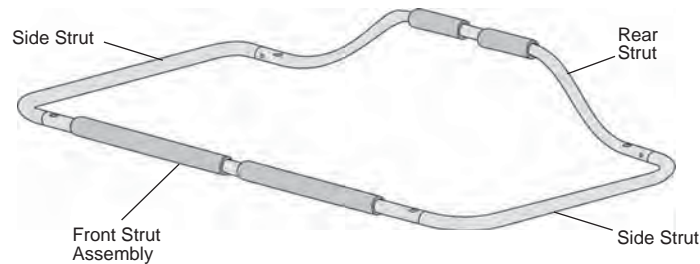

## 4 Secure Front and Right Side Strut - Top Cart

Slide the Right Corner Hook onto the Front Strut. Place a 1/2-13 Jam Nut over the hole in the Front Strut. Install a Top Cart Braking Castor through both struts, the hook and into the Jam Nut.

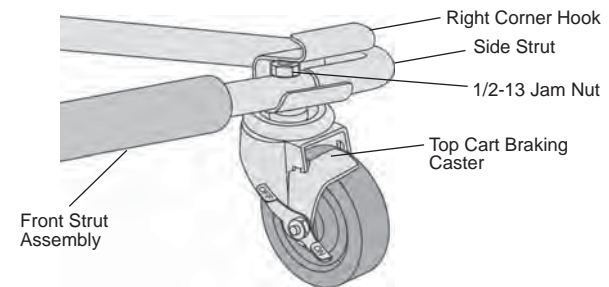

# HOSS™ Top Cart Installation Instructions

## 5 Secure Rear Strut to Top Cart Assembly

Place a Top Cart Caster without a brake through the larger holes where the Side and Rear Struts join and secure it with a 1/2-13 Jam Nut. Then install a 1/4-20 x 1.5" Hex Bolt, a 1/4" Washer and a 1/4-20 Hex Nut.

Repeat this procedure with the other Side Strut / Rear Strut Assembly.

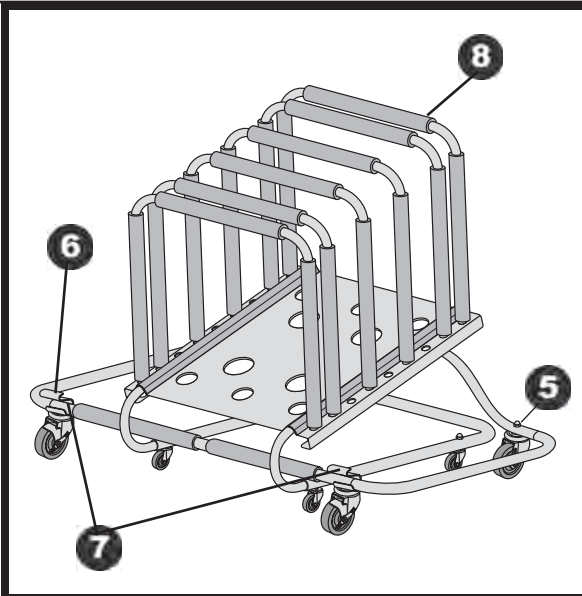
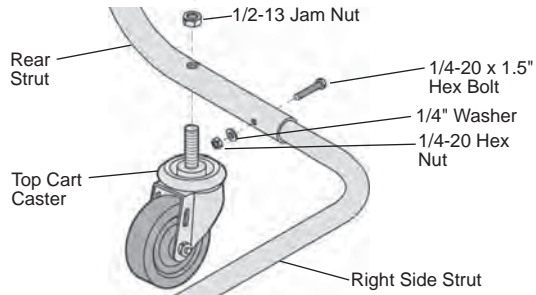

## 7 Install Corner Hook Rubber Pads - Top Cart

Locate the Corner Hook Rubber Pads in the parts kit. Orient them to fit squarely on the Corner Hooks. Remove the backing from the pads and press them firmly onto the Corner Hooks.

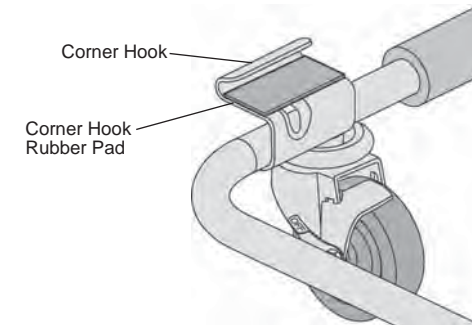

## 6 Install Left Front Braking Caster and Corner Hook - Top Cart

Slide the Left Corner Hook onto the Front Strut. Slide the end of the Left Side Strut into the end of the Front Strut Assembly. Place a 1/2-13 Jam Nut over the hole in the Front Strut. Install a Top Cart Braking Caster through both struts, the hook and into the Jam Nut. Securely tighten all hardware.

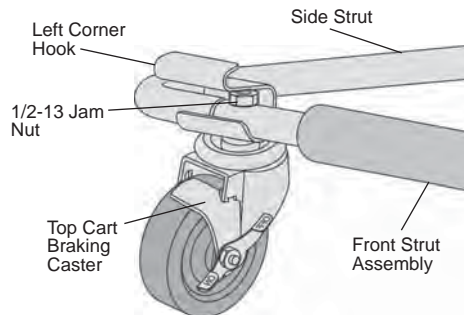

## 8 Assemble Dividers - Door Cart

Locate the Right and Left Door Cart Dividers in the parts kit. Slide a Foam Sleeve over one half of each pair of Dividers. Press the Divider halves together and center the Foam Sleeve. Slide an additional Foam Sleeve over each leg of each Divider. Leave at least 2-1/4" of the tube exposed at the bottom of each leg. Assemble all six (6) Dividers.

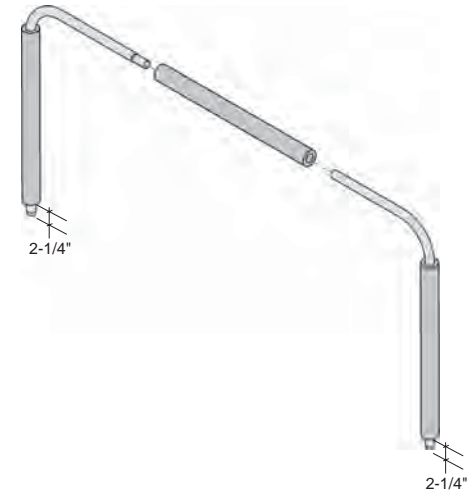

# HOSS™ Top Cart Installation Instructions

## 9 Install Angle Legs and Casters on Door Cart Rear Strut

Locate the Angle Legs and Rear Strut in the parts kit. Slide the Angle Legs into the ends of the Rear Strut and align the holes. Install a Door Cart Caster in each set of holes with a 3/8-16 Acorn Nut. Do not tighten the nuts at this time.

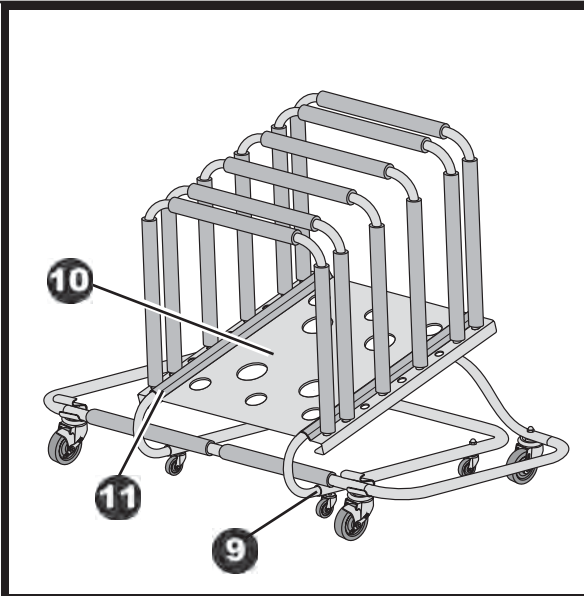
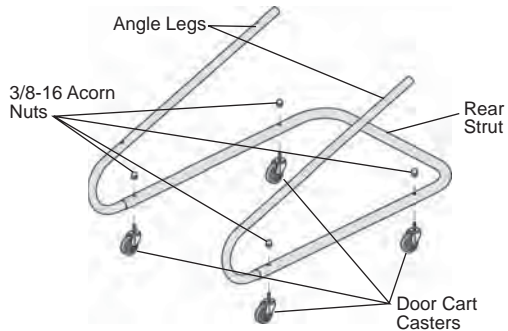

## 11 Install Rubber Strips

Orient the Rubber Strips along the top of the mounting ridges, over the heads of the Truss Head Screws. Center the strips from top to bottom on the pan. Peel the backing off the strips a little at a time and press them firmly into place.

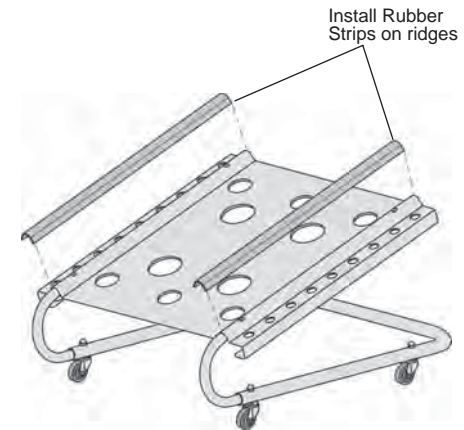

## 10 Install Door Cart Pan

Orient the Door Cart Pan on the Door Cart Assembly so the holes in the lower ledge along the side of the pan are toward the bottom of the pan in relation to the holes in the top layer. Align the mounting holes in the pan with the mounting holes on the Angle Legs and install a 1/4-20 x 1.5 Truss Head Screw, 1/4" Washer and 1/4-20 Hex Nut in each hole.

Tighten the Truss Head Screws then tighten the Acorn Nuts that secure the Casters to the Door Cart.

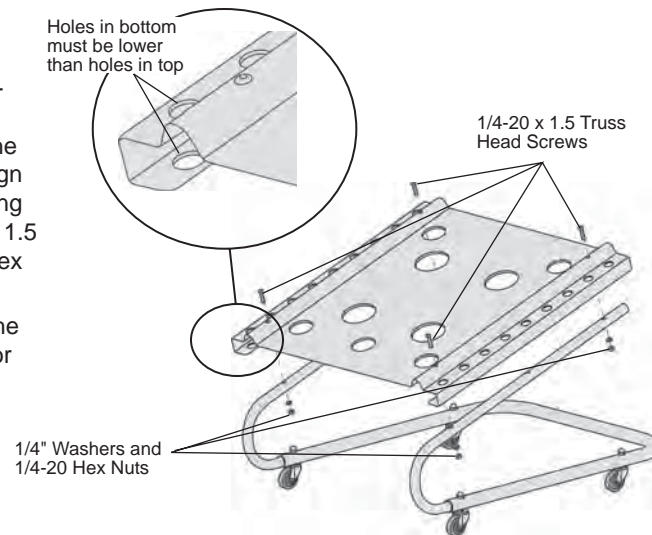

## HOSS™ Top Cart Installation Instructions

**! WARNING** The maximum load for the Door Cart is 235 lbs.

### 12 Install Dividers in Door Cart

Insert the Dividers into the holes along the sides of the Cart Pan. The ends of the Dividers should fit securely into the mounting holes. The Dividers can be set in whichever configuration you need to hold your doors.

**NOTE** Make sure that the Foam Sleeves on the legs of the Dividers are high enough to allow the Dividers to fit snugly in the mounting holes.

Store taller doors toward the back of the Door Cart with shorter doors toward the front.

**NOTE Important:** After loading all equipment on the Door Cart, make sure the Divider ends are **NOT** touching the inside of the hardtop glass.

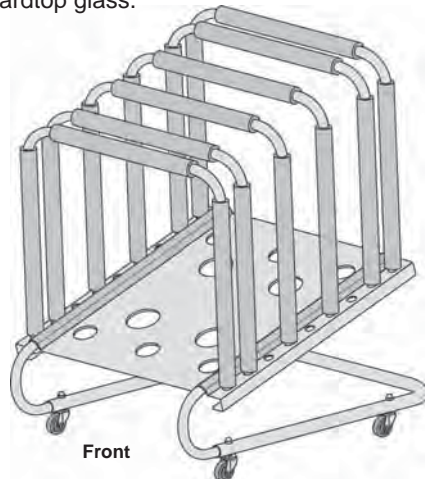

**! CAUTION** Four or more people are required to lift the hardtop safely.

### 13 Removing your Hardtop

Release the hard top from the vehicle, but leave it in place. A T40 Torx Wrench has been provided in the parts kit for this purpose. Place the Top Cart against the rear of the top with the Rear Strut toward the top.

Make sure that the Right and Left Corner Hooks on the cart line up to support the rear flange of the hardtop.

Let the top rest on the vehicle.

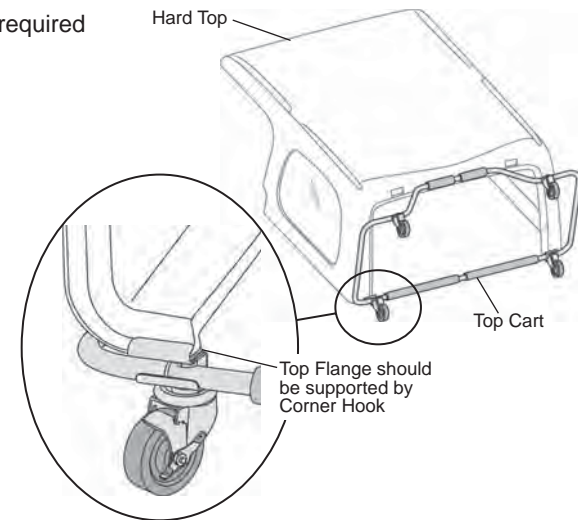

### 14 Removing your Hardtop

Orient the Top Cart Strap with the buckle in the middle of the strap facing up. Thread the straight end of the strap between the hard top and the Rear Strut in the space between the two Foam Sleeves.

If you have a one piece top, take the hook end of the strap up and hook it to the front edge of the top.

If you have a two piece top, wrap the strap around the front edge and back to hook it to the upper inside lip of the rear window.

Do not twist the strap.

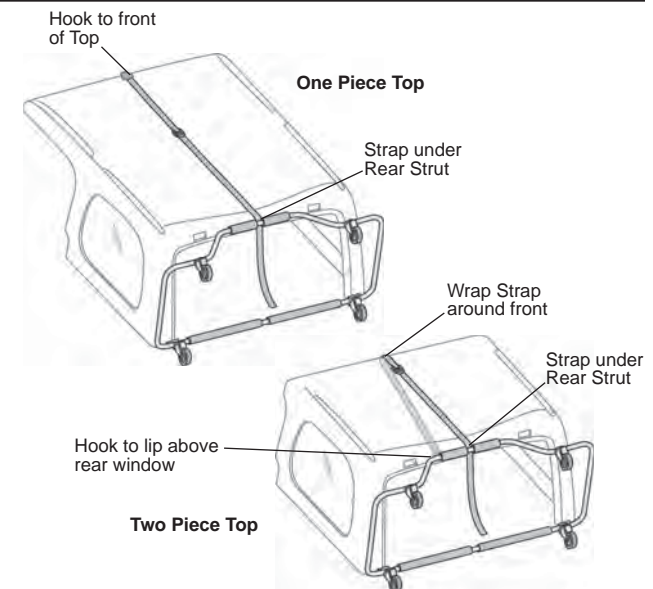

# HOSS™ Top Cart Installation Instructions

## 15 Removing your Hardtop

Wrap the straight end of the strap around the Rear Strut and toward the buckle in the middle of the strap. Check again to make sure that the strap is not twisted.

Thread the end of the strap through the buckle and pull it as tight as possible. Check that the hook is secure on the front edge of the top.

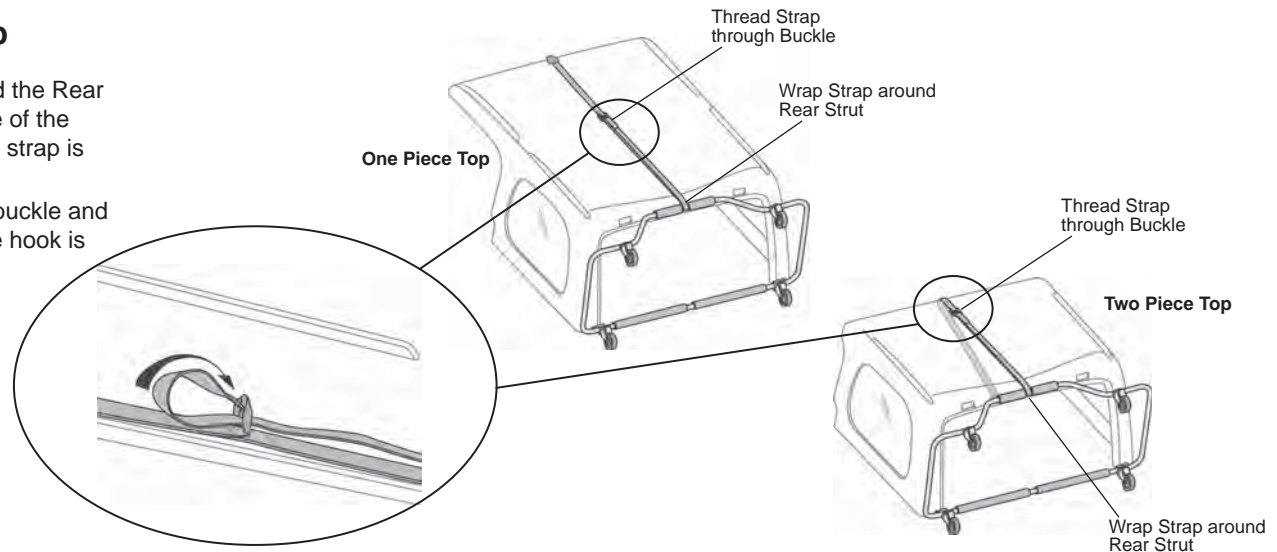

### CAUTION

Four or more people are required to lift the hardtop safely.

## 16 Removing your Hardtop

If you have a two piece top, remove the front piece to reduce the weight.

Use the Side Struts as handles to lift the hard top and Top Cart off the vehicle and move toward the rear. Slowly place the top in its normal position down on the ground next to the vehicle. Recheck that the strap is secure.

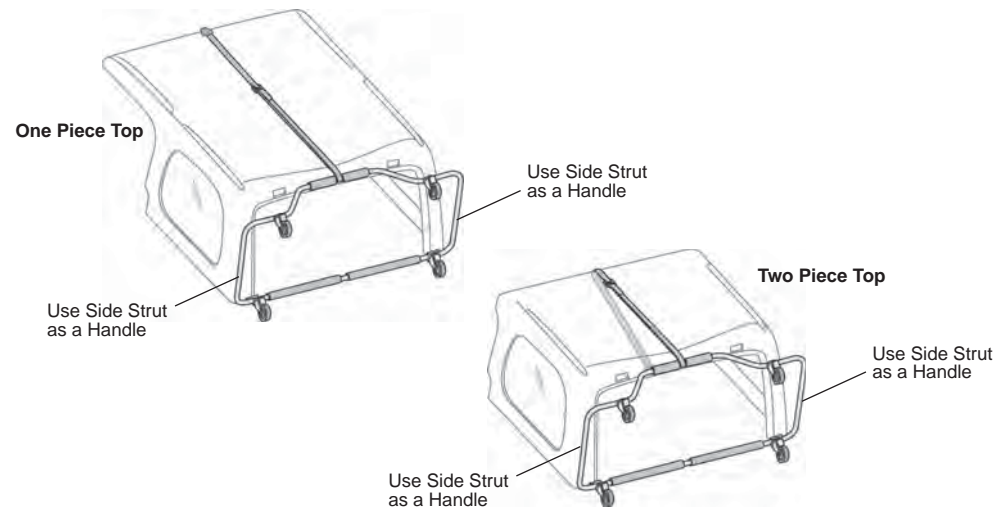

## HOSS™ Top Cart Installation Instructions

---



**CAUTION** Two or more people are required to lift the hardtop safely.

DO NOT allow the hardtop to rock backwards while lifting.

### 17 Removing your Hardtop

Lock the Front Brake Casters. Slowly lift the front of the hardtop until it is completely resting on the Top Cart Casters. Do not allow the hardtop to rock backwards as it approaches the full upright position.



---

### 18 Storing your Hardtop

Release the Front Brake Casters and roll the hardtop/cart assembly into position for storage. Once the cart is in this position, again lock the front casters.



## HOSS™ Top Cart Installation Instructions

---

### Limited Warranty

We warrant our product to be free from defects in material and workmanship, for the terms specified below, provided there has been normal use and proper maintenance. This warranty applies to the original purchaser only. All remedies under this warranty are limited to the repair or replacement of any item or items found by the factory to be defective within the time period specified.

If you have a warranty claim, first you must call our factory at the number below for instructions. You must retain proof of purchase and submit a copy with any items returned for warranty work. Upon completion of warranty work, if any, we will return the repaired or replaced item or items to you freight prepaid. Damage to our products caused by accidents, fire, vandalism, negligence, misinstallation, misuse, Acts of God, or by defective parts not manufactured by us, is not covered under this warranty.

THE WARRANTY TIME PERIOD IS AS FOLLOWS: ALL "PRODUCTS" MANUFACTURED BY OUR COMPANY: ONE YEAR FROM DATE OF PURCHASE.

ANY IMPLIED WARRANTIES OF MERCHANTABILITY AND/OR FITNESS FOR A PARTICULAR PURPOSE CREATED HEREBY ARE LIMITED IN DURATION TO THE SAME DURATION AND SCOPE AS THE EXPRESS WRITTEN WARRANTY. OUR COMPANY SHALL NOT BE LIABLE FOR ANY INCIDENTAL OR CONSEQUENTIAL DAMAGE.

Some states do not allow limitations on how long an implied warranty lasts, or the exclusion or limitation of incidental or consequential damages, so the above limitations or exclusions may not apply to you.

This warranty gives you specific legal rights, and you may also have other rights which vary from state to state.



For further information or request for warranty work, please contact:  
Bestop Inc. Customer Service  
(800) 845-3567  
(303) 465-1755