





Installation Instructions









HighRock 4x4™ Slider Step

Vehicle Application:

- Jeep YJ and TJ Wrangler
1986 – 2006
Part Number: 49312

www.Bestop.com - We're here to help! Visit our web site and click on "[Ask a Question](#)". Click here for more [Jeep® Accessories by Bestop](#).

INSTALLATION TIME	SKILL LEVEL
 1 Hour	 3 - Moderately Difficult

TOOLS			
 Power Drill 5/16" and 17/32" Bits	 Ratchet	 Socket 14mm, 13mm and 10mm	 Wrench 10mm
 Allen Wrench 5mm and 6mm	 Adjustable Wrench	 Center Punch	 Safety Glasses



DO NOT INSTALL THIS PRODUCT ON ANY VEHICLE OTHER THAN THOSE LISTED ABOVE. This product is only designed for the vehicles listed above. Failure to install this product on the proper vehicle could cause injury to the vehicle occupants and damage to the product.

⚠ WARNING This product is designed primarily to enhance the appearance of the vehicle and to shield the occupants from ordinary weather conditions. Do not rely in any way on the components of this product to contain occupants within the vehicle, or to protect against injury or death in the event of an accident. This product will not protect the occupants from falling objects. Never operate the vehicle in excess of manufacturer's specifications.

WEAR SEAT BELTS AT ALL TIMES

Read and follow, precisely, all installation instructions provided when installing product. Failure to do so may result in a poor fit and could place occupants of the vehicle in a potentially dangerous situation.

HighRock 4x4™ Slider Step Installation Instructions

Parts List and Hardware Identification

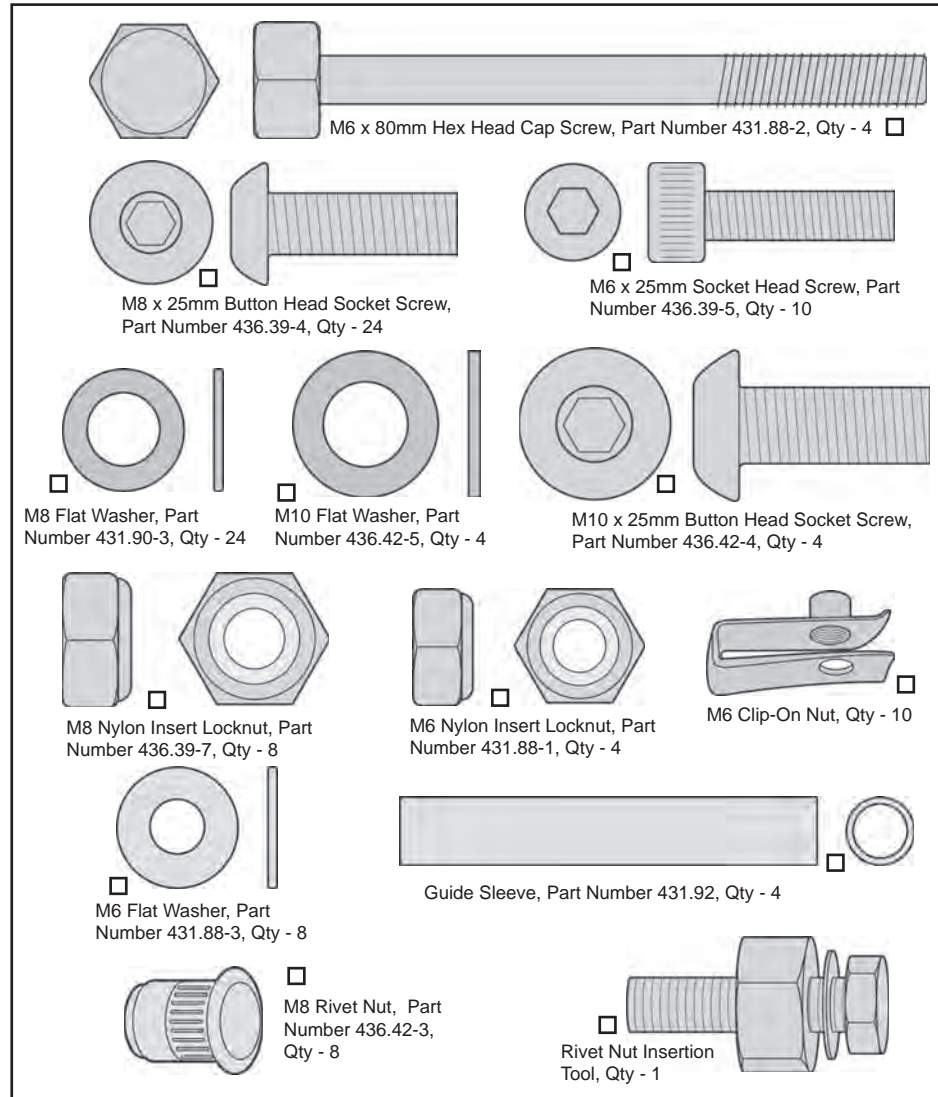
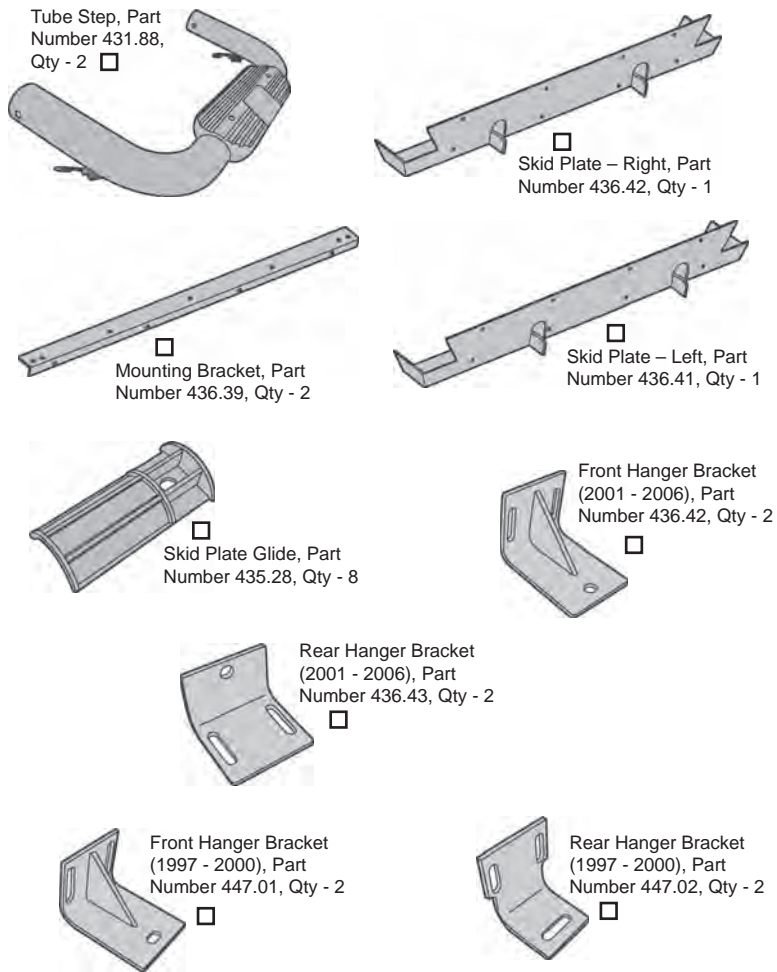

HighRock 4x4™ Slider Step Installation Instructions

TJ Installation

1 Assemble Tube Step to Skid Plate

Hook Bungee Cord on Tube Step onto Skid Plate and pull down onto Step Tube until Step Tube Slides into Skid Plate.

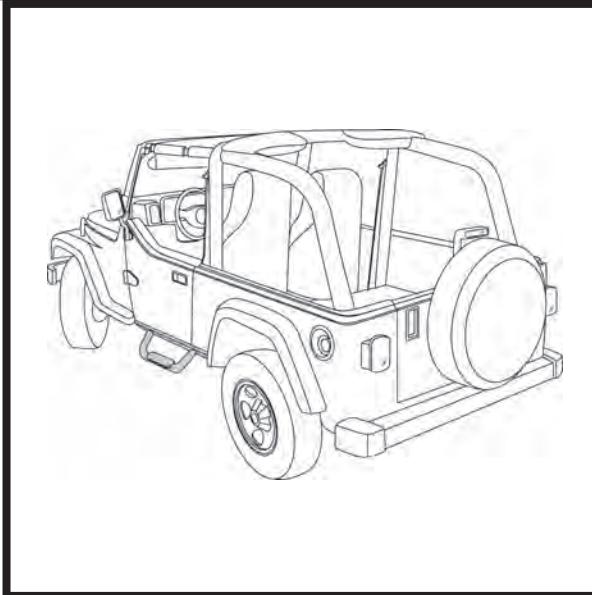
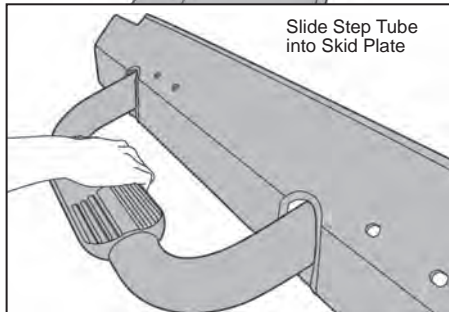
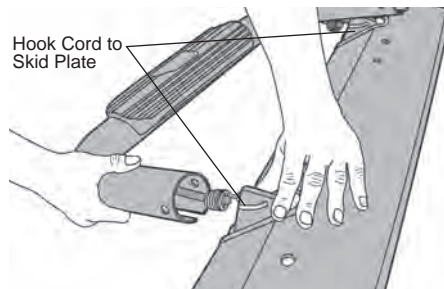

2 Install Skid Plate Glides

Slide two (2) Skid Plate Glides into each end of Step Tube.

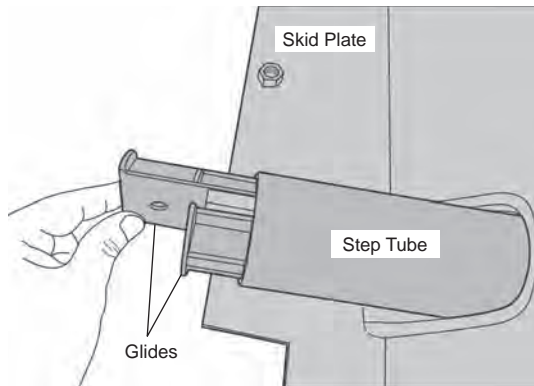

3 Secure Step Tubes to Skid Plate

Slide Guide Sleeve through Step Tube and Skid Plate Glides and secure with M6 x 80mm Hex Head Cap Screw, two (2) M6 Washers and an M6 Nylon Insert Locknut. Repeat on both ends of the Step Tube.

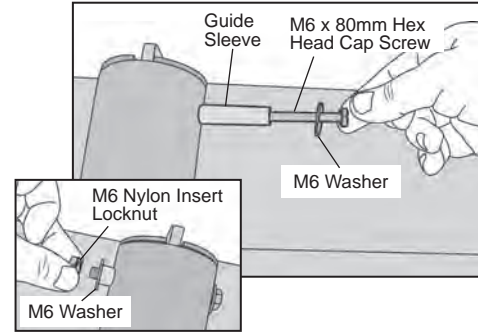
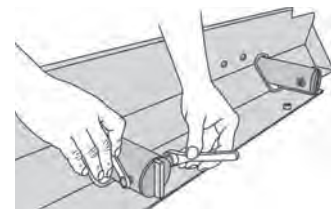

4 Preassemble Remaining Slider Step

Repeat Steps 1 – 3 with the remaining Slider Step.

HighRock 4x4™ Slider Step Installation Instructions

5 Install Rivet Nuts

Use a 14mm socket and adjustable wrench to install Rivet Nuts into the following holes.

Slide the Washer over the Rivet Nut Insertion Assembly Bolt and follow it with the Rivet Nut Insertion Assembly Nut and a Rivet Nut.

Place the Rivet Nut Insertion Assembly into one of the holes in the frame.

Use an adjustable wrench and a 14mm socket to hold the Assembly square and flush with the hole. Make sure the Rivet Nut sits flush with the frame and tighten the bolt to 30 ft.lbs. Remove the bolt, nut and washer.

Repeat this procedure for all following holes on both sides of the vehicle.

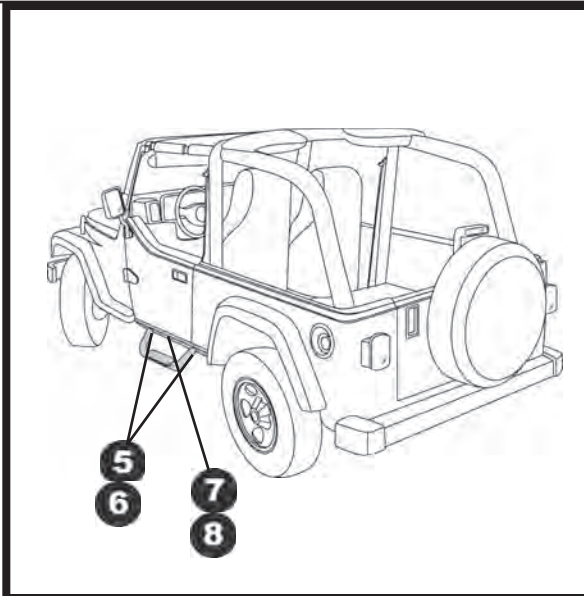
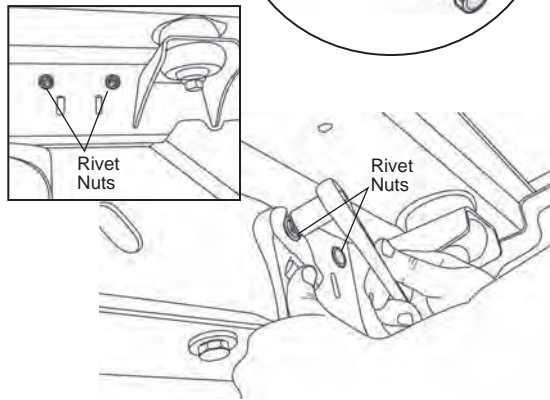
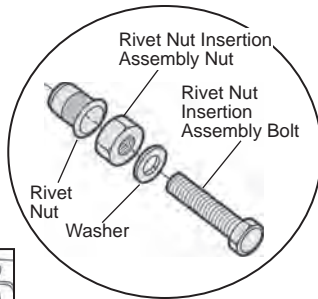

6 Install Front and Rear Hanger Brackets

Check the hole and Rivet Nut alignment with Front and Rear Hanger Brackets and select the correct brackets for your vehicle. Use M8 x 25mm Button Head Socket Screws and M8 Flat Washers to mount the Front and Rear Hanger Brackets to the Rivet Nuts.

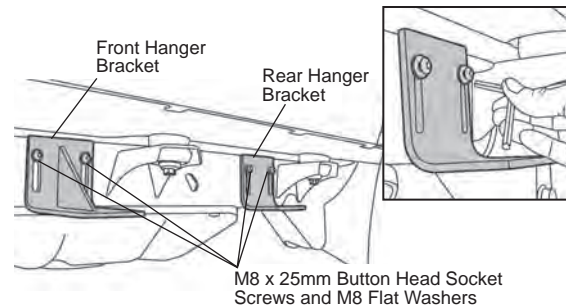

7 Install Clip-On Nuts

Slide M6 Clip-On Nuts onto the five (5) tabs under the body.

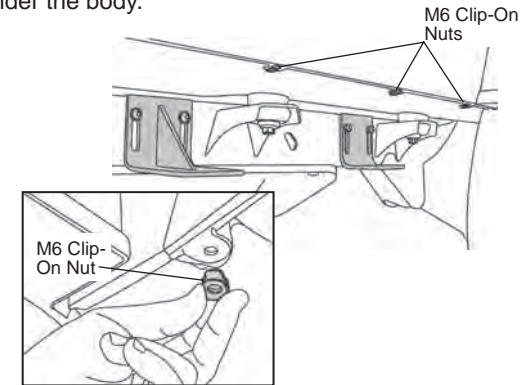

8 Install Mounting Bracket

Place the Mounting Bracket against the vehicle. Start with the middle hole and install five (5) M6 x 25mm Socket Head Screws into the Clip-On Nuts.

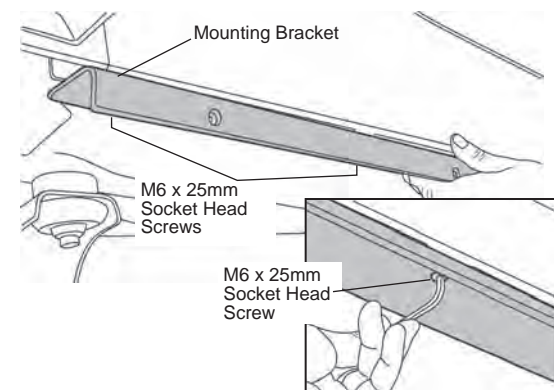

HighRock 4x4™ Slider Step Installation Instructions

9 Install Step Tube Assembly

Use four (4) M8 x 25mm Button Head Socket Screws to mount the Skid Plate to the Mounting Bracket. Do not tighten the bolts at this time.

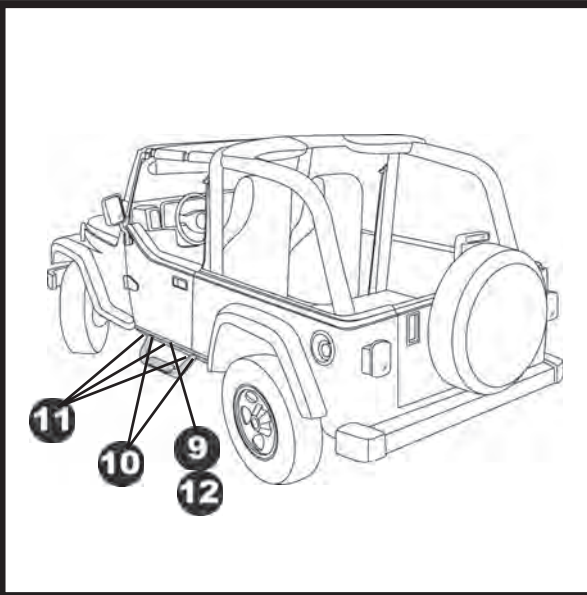
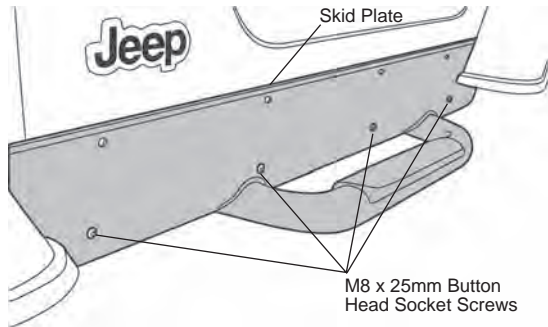

12 Install Plastic Plugs

Install Plastic Plugs in the remaining holes.

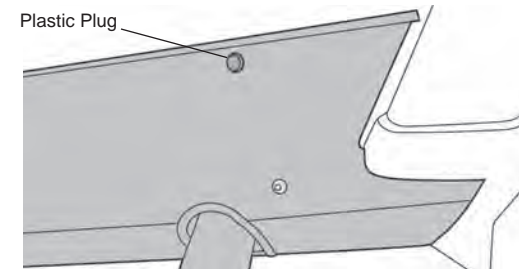

10 Secure Step Tube Assembly

Use two (2) M10 x 25mm Button Head Socket Screws and M10 Flat Washers to mount the Step Tube Assembly to the Front and Rear Hanger Brackets. Do not tighten the bolts at this time.

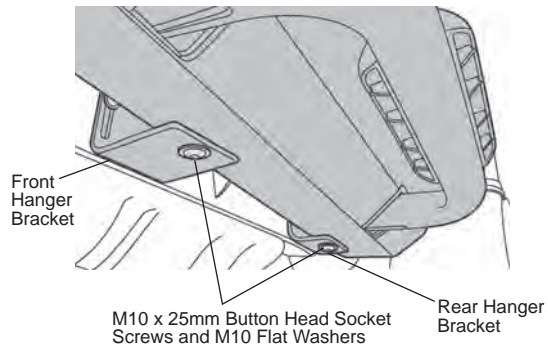

11 Secure Tube Step Assembly

Once all screws have been started, tighten the M8 x 25mm Button Head Socket Screws from Step 9 and the M10 x 25mm Button Head Socket Screws from Step 10.

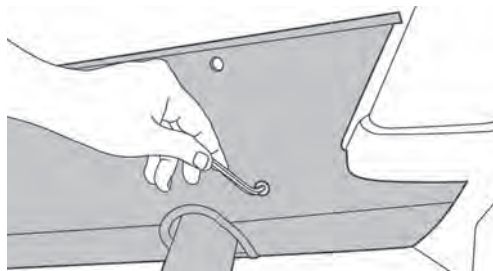

HighRock 4x4™ Slider Step Installation Instructions

YJ/Wrangler Installation

1 Assemble Tube Step to Skid Plate

Hook Bungee Cord on Tube Step onto Skid Plate and pull down onto Step Tube until Step Tube Slides into Skid Plate.

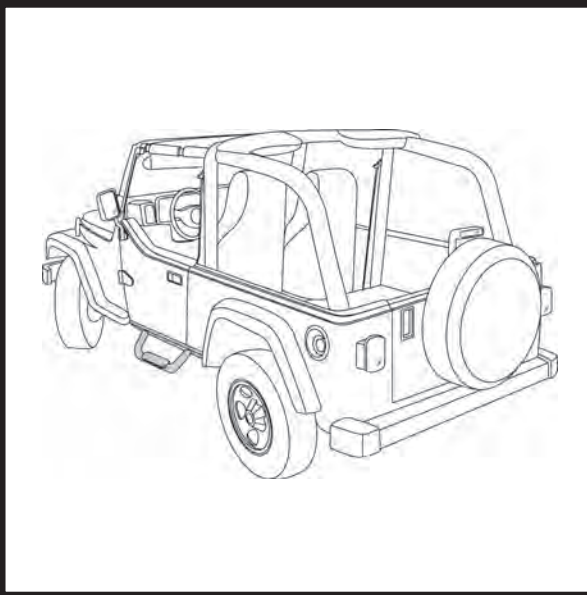
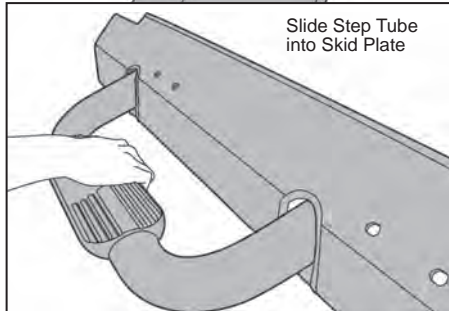
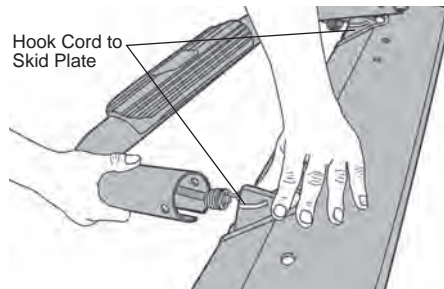

2 Install Skid Plate Glides

Slide two (2) Skid Plate Glides into each end of Step Tube.

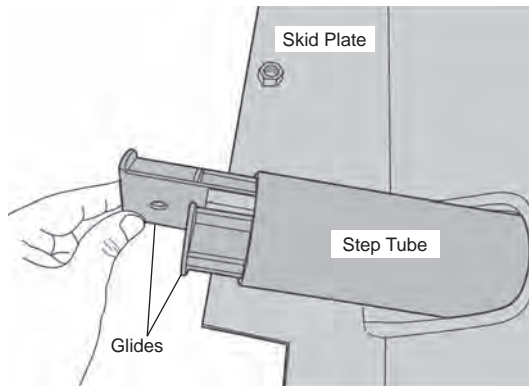

3 Secure Step Tubes to Skid Plate

Slide Guide Sleeve through Step Tube and Skid Plate Glides and secure with M6 x 80mm Hex Head Cap Screw, two (2) M6 Washers and an M6 Nylon Insert Locknut. Repeat on both ends of the Step Tube.

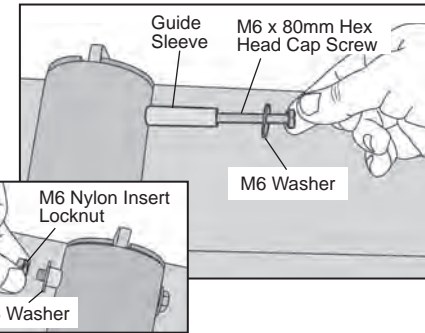
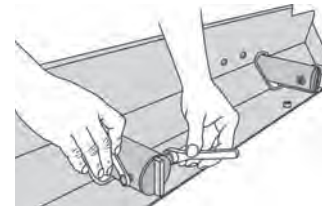

4 Preassemble Remaining Slider Step

Repeat Steps 1 – 3 with the remaining Slider Step.

HighRock 4x4™ Slider Step Installation Instructions

5 Install Front and Rear Hanger Brackets on Skid Plate Assembly

Use two (2) M10 x 25mm Button Head Socket Screws and M10 Flat Washers to loosely install the 2001 - 2006 Front and Rear Hanger Brackets to the holes toward the front of the Skid Plate Assembly. Repeat with both assemblies.

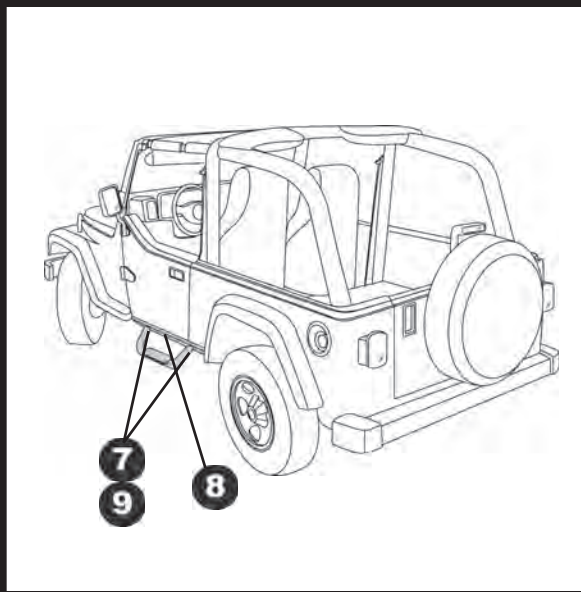
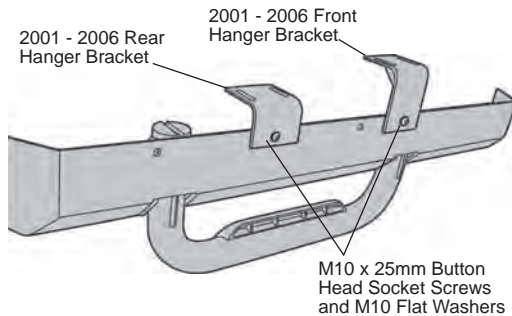

8 Mark and Drill Skid Plate Hole Locations

Mark, center punch and drill four (4) 5/16" (8mm) holes in the locations of the upper holes in the Skid Plate.

Lower the assembly and remove the Front and Rear Hanger Brackets.

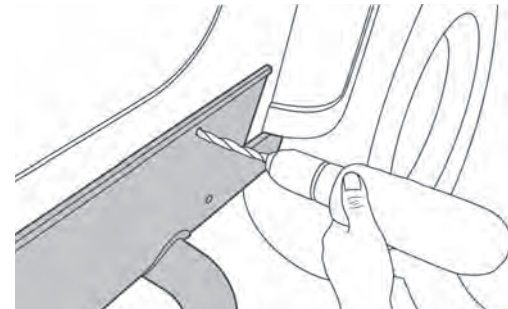

6 Align Assembly to Frame

Use a floor jack to support the Step Tube Assembly next to the vehicle with the brackets touching the frame.

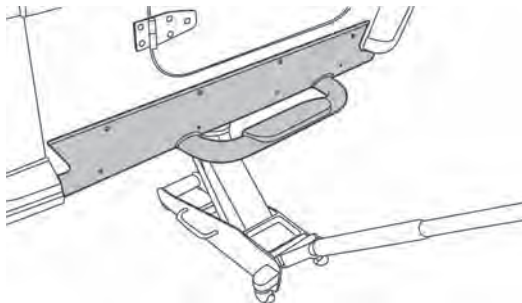

7 Mark Hanger Bracket Locations

Scribe the locations of three (3) sides of each Front and Rear Hanger Bracket on the frame. Repeat on both sides.

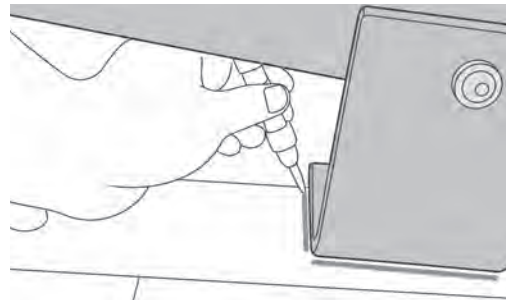

9 Mark Hanger Bracket Hole Locations

Align the Front and Rear Hanger Brackets with the marks on the frame. Use a center punch to mark the top center of the slot. Repeat for all Hanger Brackets.

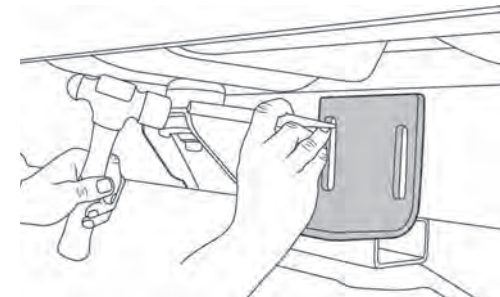

HighRock 4x4™ Slider Step Installation Instructions

10 Install Rivet Nuts in Hanger Bracket Hole Locations

Drill 17/32" (13.5mm) holes in each location marked for the Front and Rear Hanger Brackets.

Use a 14mm socket and adjustable wrench to install Rivet Nuts into the holes.

Slide the Washer over the Rivet Nut Insertion Assembly Bolt and follow it with the Rivet Nut Insertion Assembly Nut and a Rivet Nut.

Place the Rivet Nut Insertion Assembly into one of the holes in the frame.

Use an adjustable wrench and a 14mm socket to hold the Assembly square and flush with the hole. Make sure the Rivet Nut sits flush with the frame and tighten the bolt to 30 ft.lbs. Remove the bolt, nut and washer.

Repeat this procedure for all holes on both sides of the vehicle.

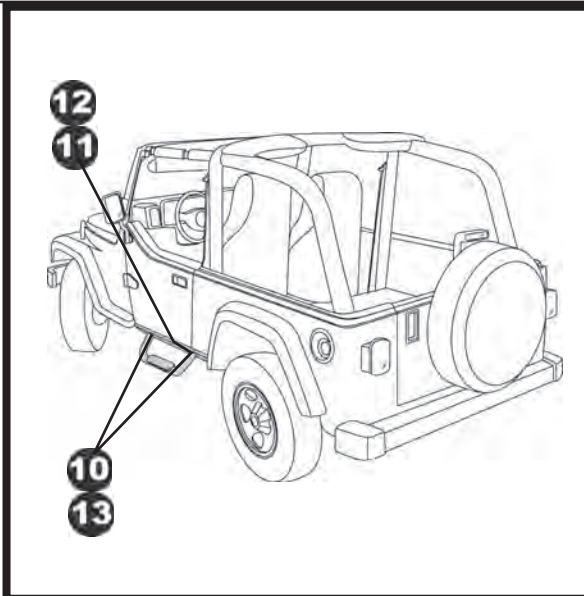
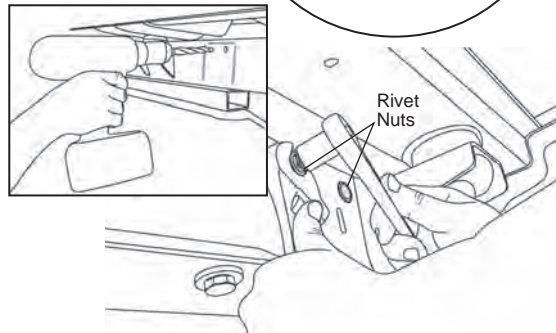
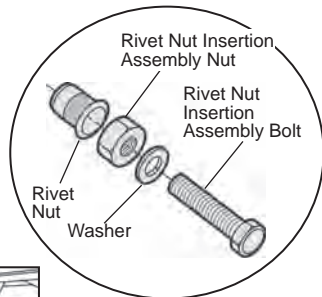

11 Install Front and Rear Hanger Brackets

Check the hole and Rivet Nut alignment with Front and Rear Hanger Bracket. Use M8 x 25mm Button Head Socket Screws and M8 Flat Washers to mount the Front and Rear Hanger Brackets to the Rivet Nuts.

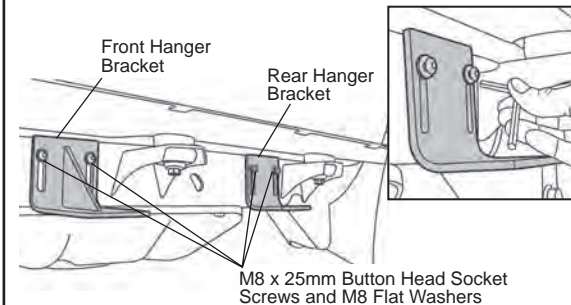

12 Install Step Tube Assembly

Use four (4) M8 x 25mm Button Head Socket Screws, M8 Flat Washers and M8 Nylon Insert Locknuts to mount the Skid Plate to the Mounting Bracket. Do not tighten the bolts at this time.

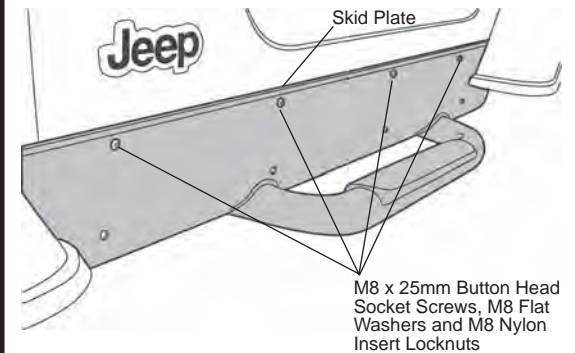

13 Secure Step Tube Assembly

Use two (2) M10 x 25mm Button Head Socket Screws and M10 Flat Washers to mount the Step Tube Assembly to the Front and Rear Hanger Brackets. Do not tighten the bolts at this time.

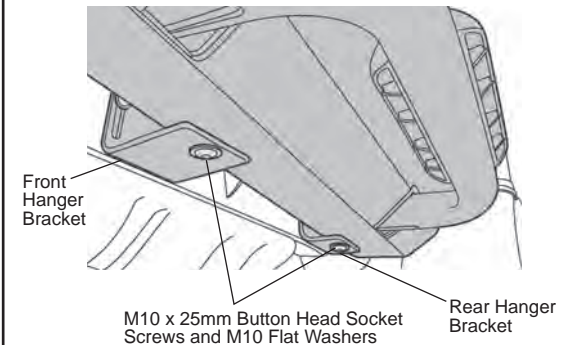

HighRock 4x4™ Slider Step Installation Instructions

14 Secure Tube Step Assembly

Once all screws have been started, tighten the M8 x 25mm Button Head Socket Screws from Step 9 and the M10 x 25mm Button Head Socket Screws from Step 10.

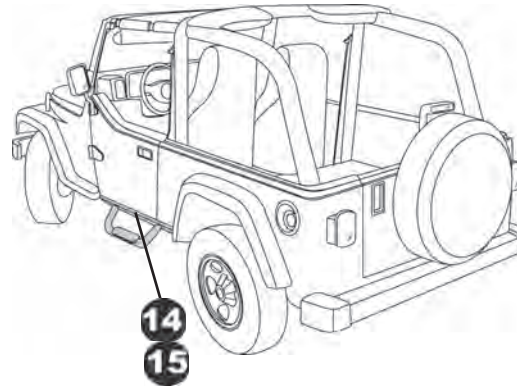
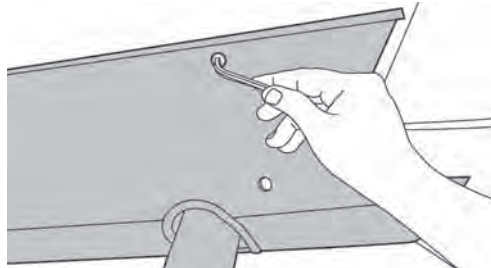

15 Install Plastic Plugs

Install Plastic Plugs in the remaining holes.

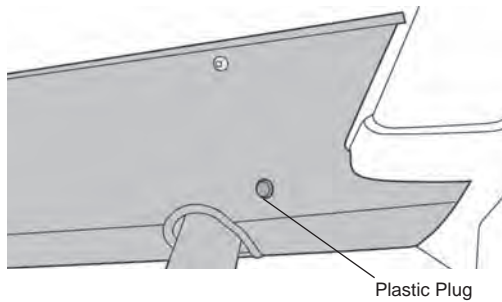

HighRock 4x4™ Slider Step Installation Instructions

LIMITED WARRANTY

We warrant our product to be free from defects in material and workmanship, for the terms specified below, provided there has been normal use and proper maintenance. This warranty applies to the original purchaser only. All remedies under this warranty are limited to the repair or replacement of any item or items found by the factory to be defective within the time period specified. If you have a warranty claim, first you must call our factory at the number below for instructions. You must retain proof of purchase and submit a copy with any items returned for warranty work. Upon completion of warranty work, if any, we will return the repaired or replaced item or items to you freight prepaid. Damage to our products caused by accidents, fire, vandalism, negligence, misinstallation, misuse, Acts of God, or by defective parts not manufactured by us, is not covered under this warranty.

THE WARRANTY TIME PERIOD IS AS FOLLOWS FOR REPLACE-A-TOP™, SAILCLOTH REPLACE-A-TOP™, SUPERTOP®, SUPERTOP® REPLACEMENT SKINS, SUNRIDER®, AND TIGERTOP®: TWO YEARS FROM DATE OF PURCHASE.

THE WARRANTY TIME PERIOD IS AS FOLLOWS FOR ALL OTHER “SOFT GOODS” MANUFACTURED BY OUR COMPANY (USING PRIMARILY VINYL, PLASTICS, AND/OR FOAM): ONE YEAR FROM DATE OF PURCHASE.

THE WARRANTY TIME PERIOD IS AS FOLLOWS FOR ALL OTHER “HARD GOODS” MANUFACTURED BY OUR COMPANY (USING PRIMARILY METALS, PLASTICS, AND/OR FIBERGLASS): ONE YEAR FROM DATE OF PURCHASE.

ANY IMPLIED WARRANTIES OF MERCHANTABILITY AND/OR FITNESS FOR A PARTICULAR PURPOSE CREATED HEREBY ARE LIMITED IN DURATION TO THE SAME DURATION AND SCOPE AS THE EXPRESS WRITTEN WARRANTY. OUR COMPANY SHALL NOT BE LIABLE FOR ANY INCIDENTAL OR CONSEQUENTIAL DAMAGE.

Some states do not allow limitations on how long an implied warranty lasts, or the exclusion or limitation of incidental or consequential damages, so the above limitations or exclusions may not apply to you. This warranty gives you specific legal rights, and you may also have other rights which vary from state to state.



For further information or request for warranty work, please contact:

Bestop Inc., Customer Service

Toll-Free: (800)845-3567

Main: (303)465-1755

E-mail: csbestop@Bestop.com

Website: www.Bestop.com