



TJ Header Windshield Channel Installation Instructions

For: Wrangler TJ

Part Number: 51238



**DO NOT INSTALL THIS PRODUCT ON ANY VEHICLE
OTHER THAN THOSE LISTED ABOVE.**

	WARNING
<p>This product is designed to enhance the appearance of the vehicle. Do not rely in any way on the components of this product to contain occupants or cargo within the vehicle, or to protect against injury or death in the event of an accident. Never operate vehicle in excess of manufacturer's specifications.</p>	
WEAR SEAT BELTS AT ALL TIMES	
<p>Read and follow, precisely, all installation instructions provided when installing this product. Failure to do so could place occupants or cargo of the vehicle in a potentially dangerous situation. After installing or reinstalling, check to make sure it has been properly installed.</p>	

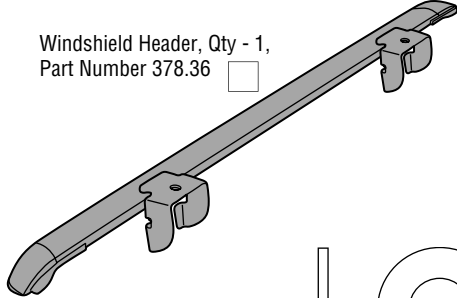
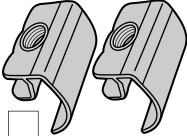
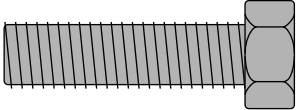
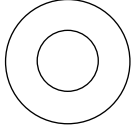
Parts List and Hardware Identification	
 <p>Windshield Header, Qty - 1, Part Number 378.36 <input type="checkbox"/></p>	 <p>J-Hook Brackets, Qty - 2, Part Number 378.61 <input type="checkbox"/></p>
 <p>5/16 x 1-1/4" Bolt, Qty - 2, Part Number 378.59 <input type="checkbox"/></p>	 <p>5/16" Washer, Qty - 2, Part Number 233.04 <input type="checkbox"/></p>

Tools Needed

1/2" Wrench

Installation



Caution

Safety glasses should be worn at all times while installing this product.

Step One

INSTALL WINDSHIELD RETAINER

Place the Windshield Retainer assembly on top of the bulb seal along the top of the Windshield.

Locate the two J-Hook Brackets in the parts kit. Orient a bracket with the hook toward the front and the threaded insert toward the top. Slide the bracket into one of the J-Hook Bracket Bases mounted to the Windshield Retainer and catch the hook in the slot in the windshield. Insert a 5/16 x 1-1/4" Bolt and a 5/16" Washer from the top of the base into the J-Hook Bracket to secure the bracket to the base. Repeat this on the other side of the vehicle.

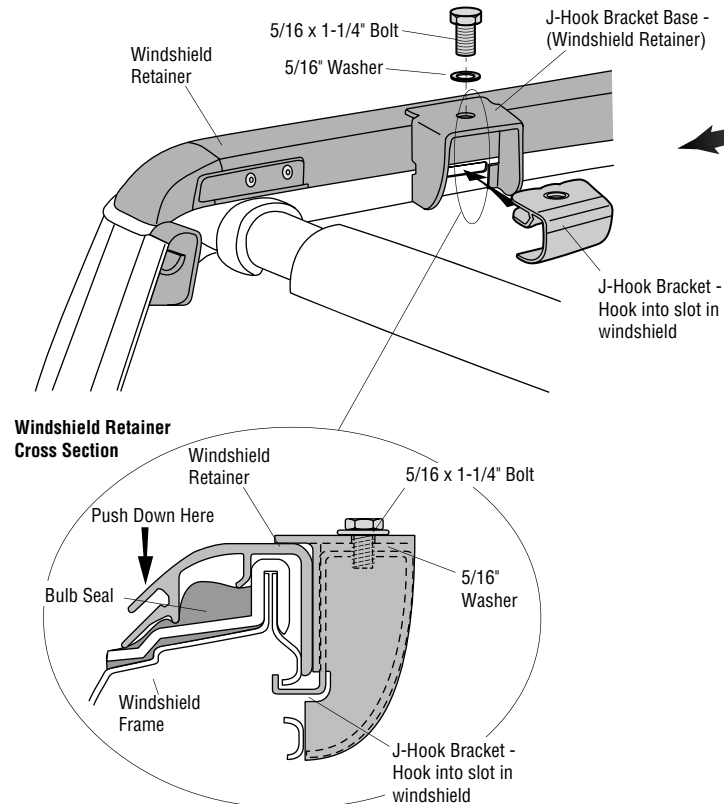

Note: While installing the Windshield Retainer/J-Hook Bracket Assembly, apply firm pressure toward the front of the vehicle to make sure that the assembly is installed correctly over the bulb seal.

