







Installation Instructions Header Windshield Channel

Vehicle Application:

- Jeep JK Wrangler and Wrangler Unlimited
2007 – Current
Part Number: 51243

www.Bestop.com - We're here to help! Visit our web site and click on "[Ask a Question](#)". Click here for more [Jeep® Accessories by Bestop](#).

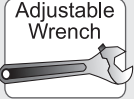
| INSTALLATION TIME | SKILL LEVEL |
|--|---|
|  3/4 Hour |  2 - Moderately Easy |

| TOOLS | | |
|--|---|--|
|  Phillips Screwdriver |  Adjustable Wrench |  Safety Glasses |



⚠ WARNING This product is designed primarily to enhance the appearance of the vehicle. Do not rely in any way on the components of this product to protect against injury or death in the event of an accident. Never operate the vehicle in excess of manufacturer's specifications.

WEAR SEAT BELTS AT ALL TIMES

Read and follow, precisely, all installation instructions provided when installing product. Failure to do so may result in a poor fit and could place occupants of the vehicle in a potentially dangerous situation.

Header Windshield Channel Installation Instructions

Parts List and Hardware Identification

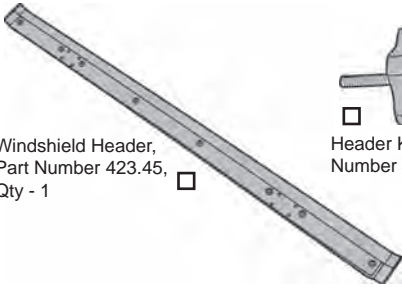

 Windshield Header, Part Number 423.45, Qty - 1



 Header Knob, Part Number 440.55, Qty - 2

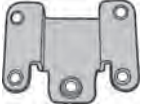

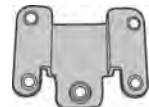

 Header Knob Base - Right, Part Number 445.08, Qty - 1



 Header Knob Base - Left, Part Number 445.09, Qty - 1



 Header Knob Plate, Part Number 445.10, Qty - 2

 #10-24 Locknut, Part Number 195.93, Qty - 8



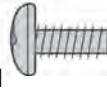

 #10-24 x 3/8" Phillips Truss Head Screw, Part Number 195.92, Qty - 8

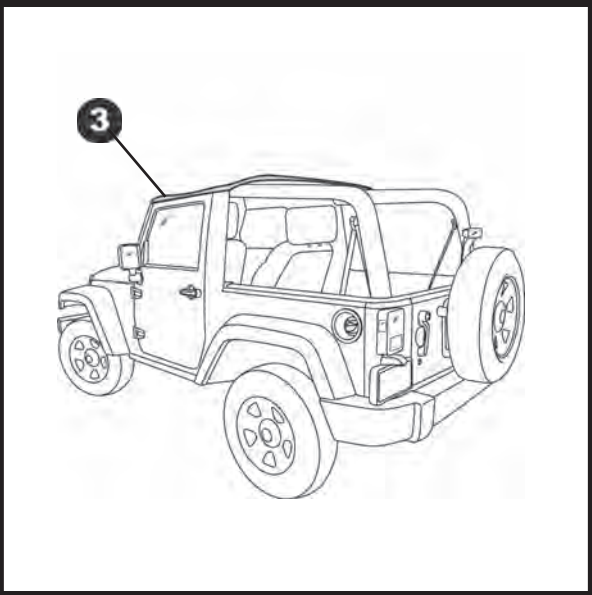

2 Snap Bikini to Header

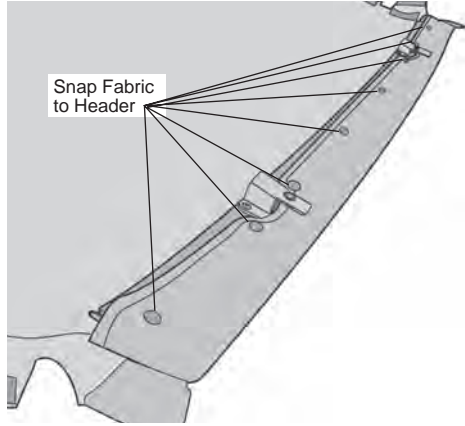
Slide the pocket sewn along the front of the Bikini over the edge of the header and snap it to the snaps.



1 Install Header Knob Bases on Header

The bottom of each Header Knob Base is stamped with an R for right or an L for left.

Place the Right Header Knob Base over the four holes with the tab of the base pointing to the front of the Header. Secure the Header Knob Base to the Header with four (4) #10-24 x 3/8" Phillips Truss Head Screws and four (4) #10-24 Locknuts.

Repeat this procedure with the left base.

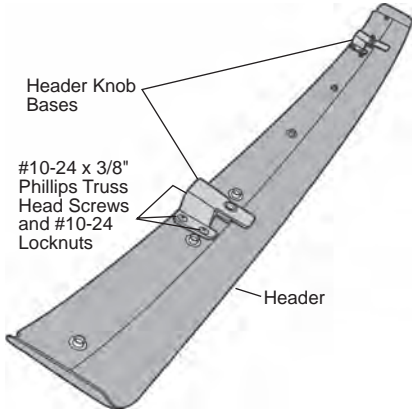

Header Windshield Channel Installation Instructions

3 Secure Header to Windshield

Center the Bikini on the vehicle. Place the tabs on the Header Knob Bases above the footman loops in the windshield frame. Place a Header Knob Plate under a footman loop. Install a Header Knob through the plate and footman loop and thread it into the Header Knob Base. Repeat this with both Header Knob Bases.

Install the rest of the Bikini as detailed in the Bikini Installation Instructions.

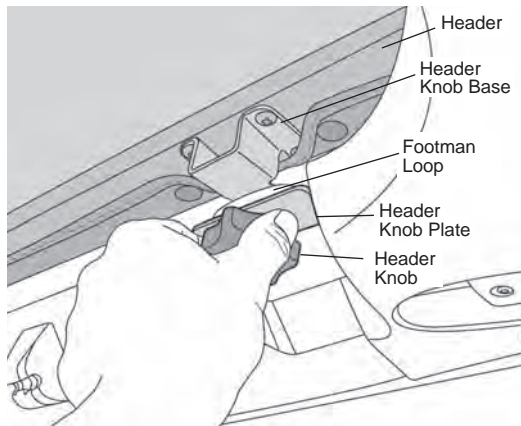

LIMITED WARRANTY

We warrant our product to be free from defects in material and workmanship, for the terms specified below, provided there has been normal use and proper maintenance. This warranty applies to the original purchaser only. All remedies under this warranty are limited to the repair or replacement of any item or items found by the factory to be defective within the time period specified. If you have a warranty claim, first you must call our factory at the number below for instructions. You must retain proof of purchase and submit a copy with any items returned for warranty work. Upon completion of warranty work, if any, we will return the repaired or replaced item or items to you freight prepaid. Damage to our products caused by accidents, fire, vandalism, negligence, misinstallation, misuse, Acts of God, or by defective parts not manufactured by us, is not covered under this warranty.

THE WARRANTY TIME PERIOD IS AS FOLLOWS FOR REPLACE-A-TOP™, SAILCLOTH REPLACE-A-TOP™, SUPERTOP®, SUPERTOP® REPLACEMENT SKINS, SUNRIDER®, AND TIGERTOP®: TWO YEARS FROM DATE OF PURCHASE.

THE WARRANTY TIME PERIOD IS AS FOLLOWS FOR ALL OTHER "SOFT GOODS" MANUFACTURED BY OUR COMPANY (USING PRIMARILY VINYLs, PLASTICS, AND/OR FOAM): ONE YEAR FROM DATE OF PURCHASE.

THE WARRANTY TIME PERIOD IS AS FOLLOWS FOR ALL OTHER "HARD GOODS" MANUFACTURED BY OUR COMPANY (USING PRIMARILY METALS, PLASTICS, AND/OR FIBERGLASS): ONE YEAR FROM DATE OF PURCHASE.

ANY IMPLIED WARRANTIES OF MERCHANTABILITY AND/OR FITNESS FOR A PARTICULAR PURPOSE CREATED HEREBY ARE LIMITED IN DURATION TO THE SAME DURATION AND SCOPE AS THE EXPRESS WRITTEN WARRANTY. OUR COMPANY SHALL NOT BE LIABLE FOR ANY INCIDENTAL OR CONSEQUENTIAL DAMAGE.

Some states do not allow limitations on how long an implied warranty lasts, or the exclusion or limitation of incidental or consequential damages, so the above limitations or exclusions may not apply to you. This warranty gives you specific legal rights, and you may also have other rights which vary from state to state.



For further information or request for warranty work, please contact:
Bestop Inc. Customer Service
Toll-Free: (800)845-3567
Main: (303)465-1755
E-mail: csbestop@Bestop.com
Website: www.Bestop.com