



# Seat Track Slide Installation Instructions



For: All Jeep® CJ5s, CJ7s and Wranglers 1976-1995

Part Number: 51255

Jeep® is a registered trademark of Chrysler and Bestop is not affiliated with Chrysler Corporation.



## WARNING

Before you begin installing this seat slider, please read all installation instructions and warnings thoroughly.

This seat slider is designed to be used on the model vehicles described above. Use of this seat slider on any other vehicle or failure to install this seat slider properly may result in an improperly mounted seat and could result in unexpected movement of the seat and loss of control of the vehicle, thereby placing the occupants of the vehicle and others in a potentially dangerous situation.

This seat system is intended to be used with seat belts at all times. Do not rely on the seat to maintain the seating position of occupants, in the event of an accident.

### WEAR SEAT BELTS AT ALL TIMES

Read and follow, precisely, all installation instructions provided when installing this product. Failure to do so may result in a poor fit and could place occupants of the vehicle in a potentially dangerous situation.

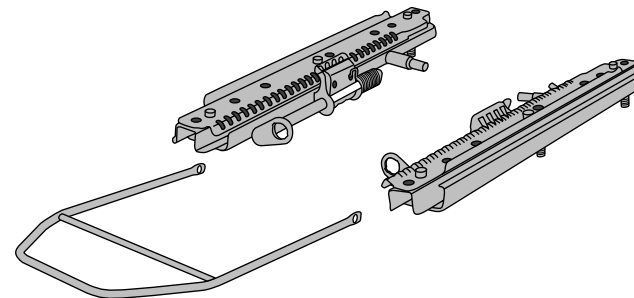

## Parts List and Hardware Identification

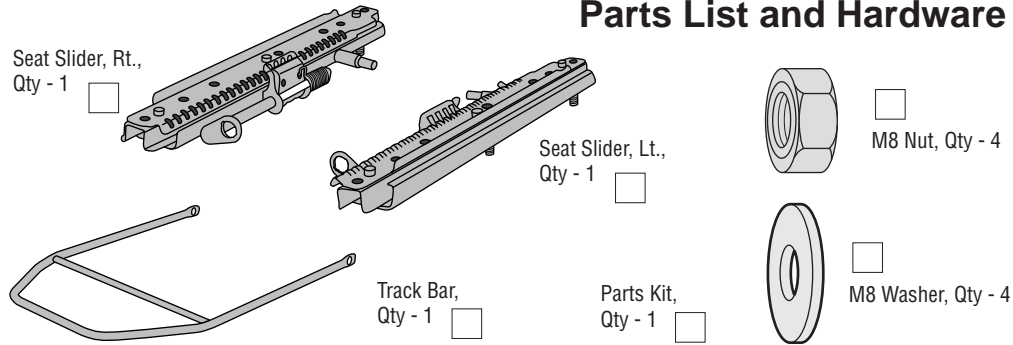

Installation Instruction Manual, Qty - 1

### Tools Needed

13 MM Hex Socket Head  
#30 Torque Wrench  
Safety Glasses

## Seat Installation



### Caution

Note: Before beginning the seat slider installation, set the parking brake, place the vehicle in gear or park and chock the wheels to reduce the risk of the vehicle unexpectedly moving, which could result in serious injury.

### Please Note

If your original seat track slide is not attached to the riser with nuts, this replacement slider will not work with your original seat riser. It will work with Bestop's replacement riser, part number 51254/51253.

### Step One

**Remove the existing seat from the vehicle.**

Remove the four (4) nuts that mount the seat track slides to the riser. Discard the nuts.

The nuts are under the ledge on the riser.

Then remove the bucket seat and track slides from the vehicle (the seat riser will remain in the vehicle).

*Left Side Shown*

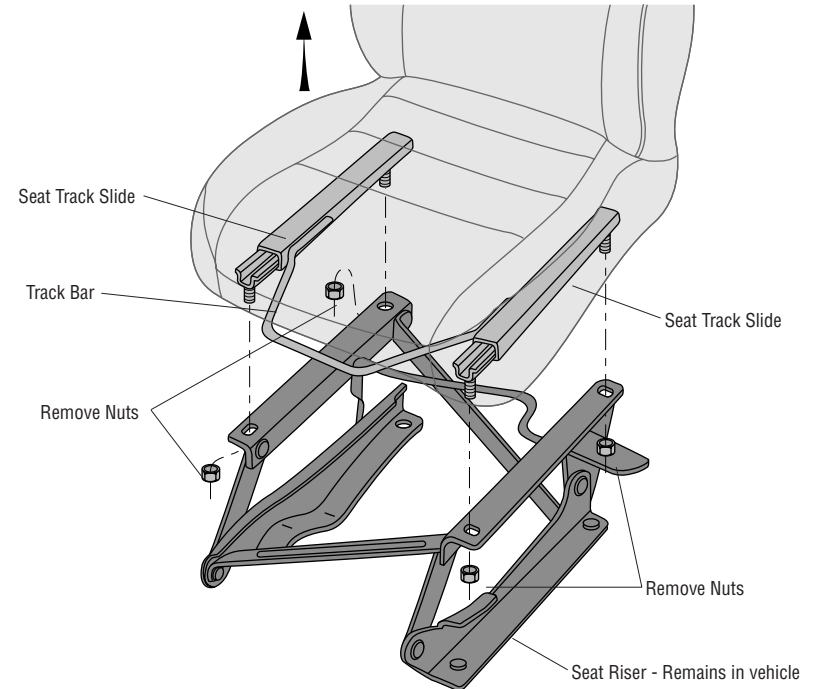

## Step Two

### Remove the tracks.

Lay the seat down with the bottom side facing up. Push down on the track bar to slide the track forward, allowing access to the rear track mounting bolts. Remove the bolts and save them for re-installation.

Track Bar - Push down to slide Track forward

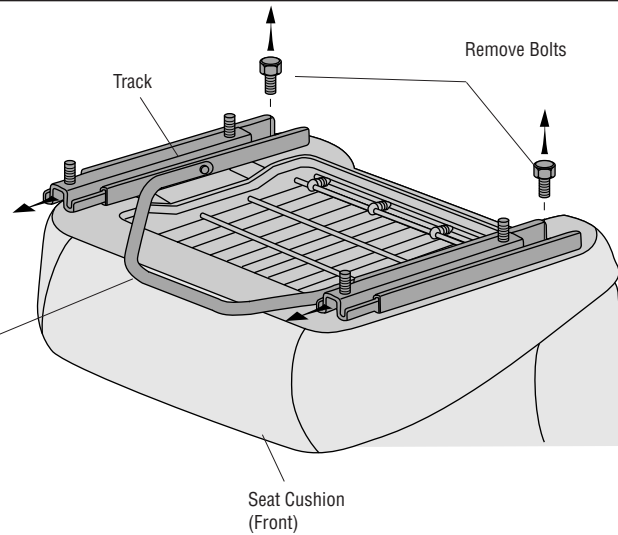

## Step Three

### Remove the tracks.

Push down on the track bar again to slide the track toward the rear of the seat. Remove the front track mounting bolts and save them.

Track Bar - Push down to slide Track toward rear

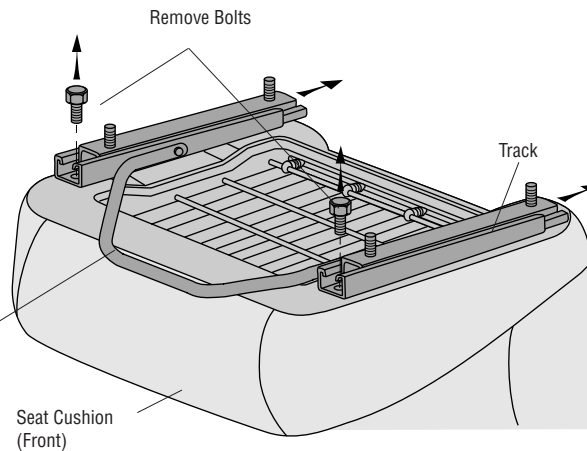

## Step Four

### Assemble Sliders and Track Bar

Push the ends of the Track Bar through the holes in the activation bar on the Sliders. Rotate the Track Bar until the ends fit through the keyholes. Insert a Nylon Bushing from the Parts Kit around the arms of the Track Bar and push the bushings into the holes in the activation bar. Then slide the holes in the ends of the Track Bar over the post on each slider and secure with a Cotter Pin.

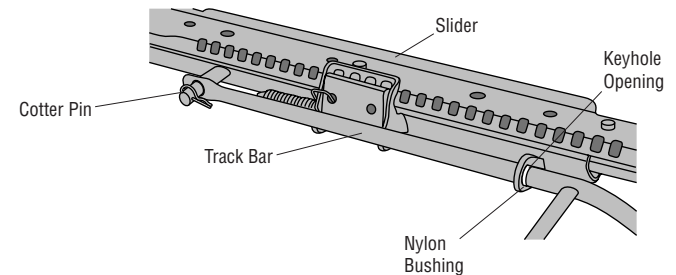

## Step Five

### Install the new tracks on the Seat.

Lay the seat down with the bottom of the seat facing up.

While the track slides are to the rear of the seat, place the tracks onto the seat. Install two of the bolts you saved in the front track mounting holes. Finger tighten the bolts.

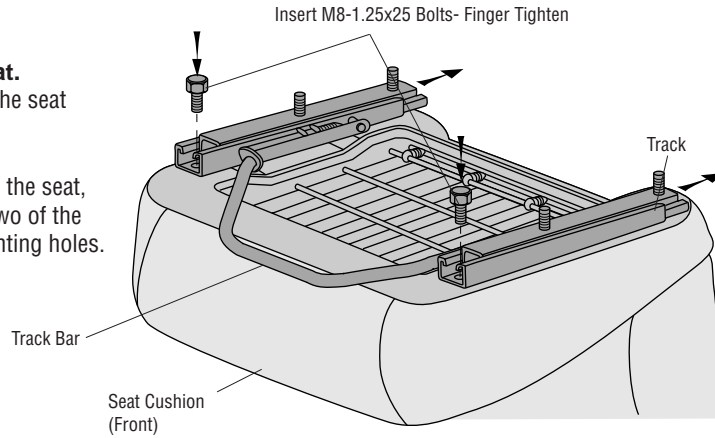

## Step Six

### Install the new tracks on the Seat.

Press down on the track bar and slide the tracks forward. Install two of the bolts you saved in the rear track mounting holes. Tighten the rear bolts to 21 ft/lbs, using a #30 Torque Wrench.

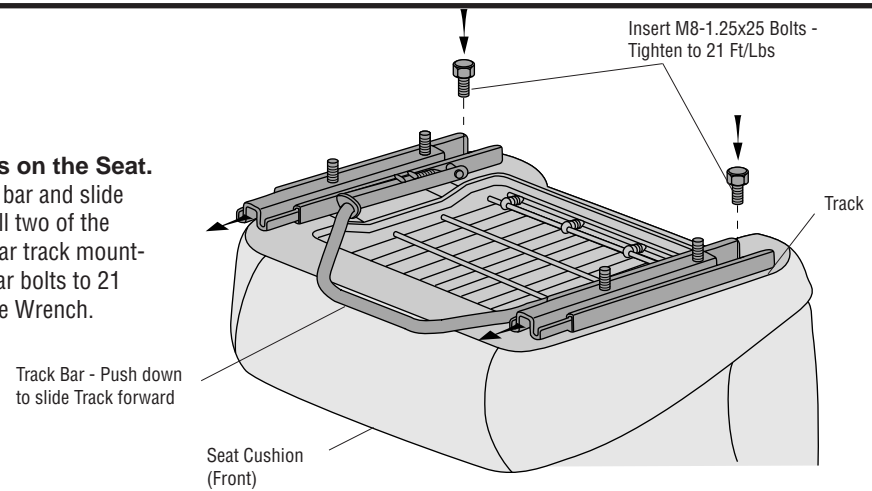



## WARNING

Failure to tighten the bolts and nuts to the specified torque can result in the seat loosening, thereby causing serious bodily injury to the vehicle occupants and to others.

### Step Seven

#### Tighten the Front Bolts.

Press down on the track bar and slide the tracks toward the rear of the seat. Tighten the front bolts to 21 ft/lbs, using a #30 Torque Wrench.

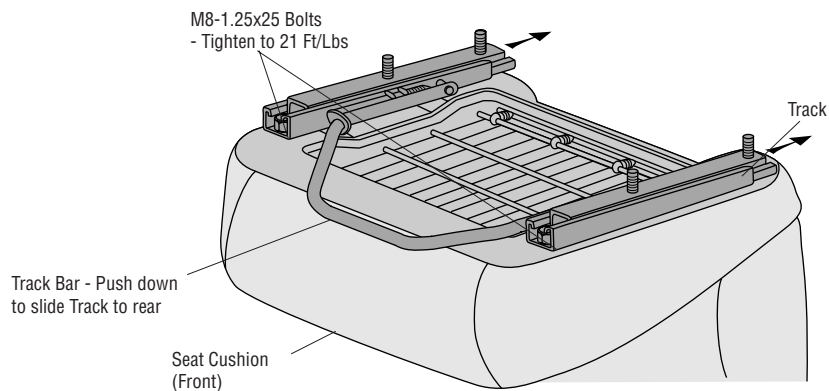

## WARNING

Failure to tighten the bolts and nuts to the specified torque can result in the seat loosening, thereby causing serious bodily injury to the vehicle occupants and to others.

### Step Eight

#### Install the Seat in the Vehicle.

Place the seat in the vehicle. Align the studs on the tracks with the holes in the seat riser. Install four (4) M8 Nuts and M8 Washers on the track studs. Tighten the nuts to 21 ft/lbs, using a #30 Torque Wrench.

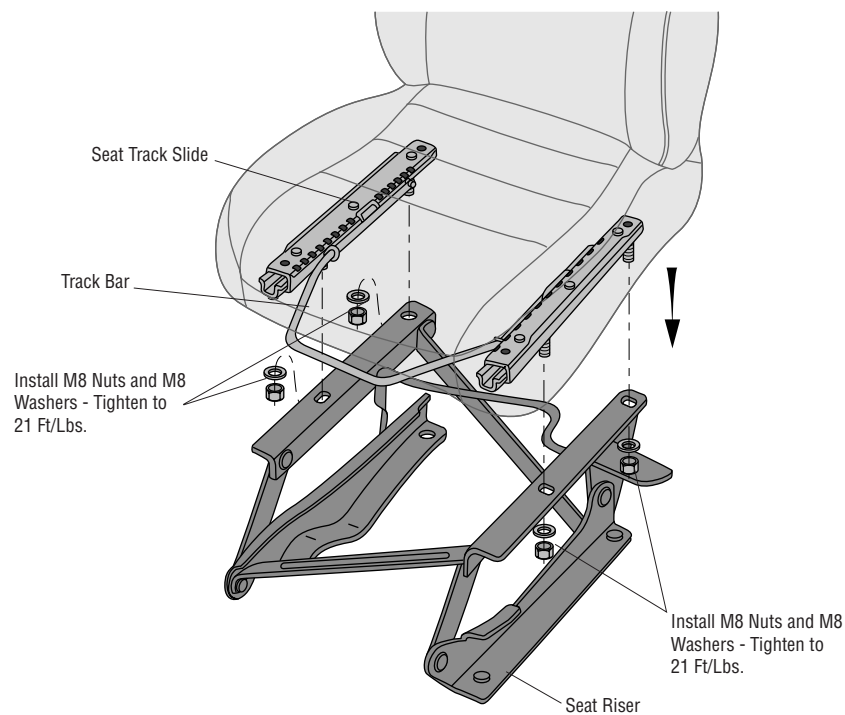



## WARNING

Never adjust the driver's seat or seat back when the vehicle is moving. You could lose control of the vehicle and injure someone.

This seat system is intended to be used with seat belts at all times. Do not rely on the seat to maintain the seating position of occupants, in the event of an accident.

Always drive and ride with your seat back upright and the lap belt snug across the hips to reduce the risk of serious injury to the abdomen or neck that could be caused by sliding under the seat belts in a collision.

Children should always ride with the seat back in the fully upright position. When the seat back is not fully upright, there is a greater risk that the child will slide under the safety belt and be seriously injured in a collision.

**WEAR SEAT BELTS AT ALL TIMES**

### LIMITED WARRANTY

We warrant our product to be free from defects in material and workmanship, for terms specified below, provided there has been normal use and proper maintenance. This warranty applies to the original purchaser only. All remedies under this warranty are limited to the repair or replacement of any item or items found by the factory to be defective within the time period specified.

If you have a warranty claim, first you must call our factory at the number below for instructions. You must retain proof of purchase and submit a copy with any items returned for warranty work. Upon completion of warranty work, if any, we will return the repaired or replaced item or items to you freight prepaid. Damage to our products caused by accidents, fire, vandalism, negligence, misinstallation, misuse, Acts of God, or by defective parts not manufactured by us, is not covered under this warranty.

THE WARRANTY TIME PERIOD IS AS FOLLOWS: ALL "GOODS" MANUFACTURED BY OUR COMPANY: ONE YEAR FROM DATE OF PURCHASE.

ANY IMPLIED WARRANTIES OF MERCHANTABILITY AND/OR FITNESS FOR A PARTICULAR PURPOSE CREATED HEREBY ARE LIMITED IN DURATION TO THE SAME DURATION AND SCOPE AS THE EXPRESS WRITTEN WARRANTY. OUR COMPANY SHALL NOT BE LIABLE FOR ANY INCIDENTAL OR CONSEQUENTIAL DAMAGE.

Some states do not allow limitations on how long an implied warranty lasts, or the exclusion or limitation of incidental or consequential damages, so the above limitations or exclusions may not apply to you.

This warranty gives you specific legal rights, and you may also have other rights which vary from state to state.

For further information or request for warranty work, please contact:

Bestop Inc.  
Customer Service  
(800)346-3910  
(303)465-1755

