













Installation Instructions Supertop® with Tinted Windows

Vehicle Application:

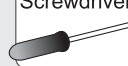
- Ford Bronco
1966 – 1977
Part Number: 51533

www.Bestop.com - We're here to help! Visit our web site and click on "Ask a Question". Click here for more [Jeep Accessories by Bestop](#).

INSTALLATION TIME	SKILL LEVEL
 <p>3 Hours</p>	 <p>3 - Moderately Difficult</p>

TOOLS			
 <p>Wrench 3/8", 7/16" and 1/2"</p>	 <p>Power Drill 3/16" and 3/32" Bits</p>	 <p>Phillips Screwdriver</p>	 <p>Center Punch</p>
 <p>Pencil</p>	 <p>Chalk</p>	 <p>Tape Measure</p>	 <p>Safety Glasses</p>



 **CAUTION** Safety glasses should be worn at all times while installing this product.

Installation Tips

Before you begin installing this assembly, read all instructions thoroughly.

For a smooth fit:

For ease in installation, the product should be installed at temperatures above 72° F. Below this temperature, the fabric may contract an inch or more, making it difficult to fit to the vehicle. It is normal for fabric to contract and wrinkle when stored in the shipping carton. Within a few days after the installation, the fabric will relax and the wrinkles will disappear.

 **WARNING** This product is designed primarily to enhance the appearance of the vehicle and to shield the occupants from ordinary weather conditions. Do not rely in any way on the components of this product to contain occupants within the vehicle, or to protect against injury or death in the event of an accident. This product will not protect the occupants from falling objects. Never operate the vehicle in excess of manufacturer's specifications.

WEAR SEAT BELTS AT ALL TIMES

Read and follow, precisely, all installation instructions provided when installing product. Failure to do so may result in a poor fit and could place occupants of the vehicle in a potentially dangerous situation.

Supertop® – Installation Instructions

Top Fabric	Qty - 1
Quarter Window, Right	Qty - 1
Quarter Window, Left	Qty - 1
Rear Window	Qty - 1

Parts List and Hardware Identification



Windshield Adapter-
Passenger Side, Qty - 1,
Part No. 370.66

Windshield Adapter-
Driver's Side, Qty - 1,
Part No. 370.67

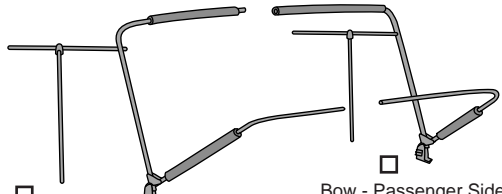

Bow - Driver's Side,
Qty - 1, Part No. 370.71

Bow - Passenger Side,
Qty - 1, Part No. 370.70

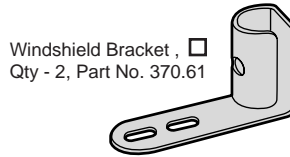

Windshield Bracket ,
Qty - 2, Part No. 370.61

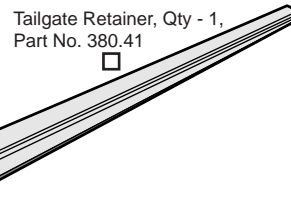

Tailgate Retainer, Qty - 1,
Part No. 380.41

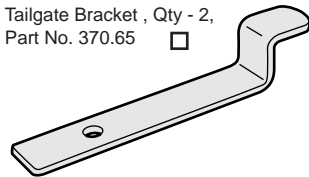

Tailgate Bracket , Qty - 2,
Part No. 370.65

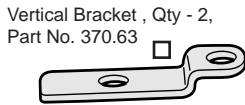

Vertical Bracket , Qty - 2,
Part No. 370.63



Side Belt Rail - Driver's
Side, Qty - 1, Part No.
370.95

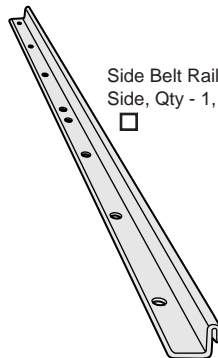

Side Belt Rail - Passenger
Side, Qty - 1, Part No. 370.94

- 5/16-18 x 1" Phillips Head Bolt, Qty - 14, Part Number 236.20
- 1/4" x 3/4" OD Washer, Qty - 16, Part Number 257.93
- 5/16" Washer, Qty - 14, Part Number 233.04
- 5/16-18 Tapping Plate, Qty - 14, Part Number 200.50
- 1/4-20 x 3/4" Pan Head Bolt, Qty - 8, Part Number 257.92
- 1/4-20 Hex Lock Nut, Qty - 8, Part Number 198.26
- 10-24 Lock Nut, Qty - 4, Part Number 195.93
- 10-24 x 3/8" Pan Head Screw, Qty - 4, Part Number 195.92
- #6 x 3/8" Screw, Qty - 2, Part Number 9.69
- #14 x 1/2" Pan Head Screw, Qty - 2, Part Number 243.47
- Body Stud, Qty - 2, Part Number 9.68

Supertop® – Installation Instructions

Check Windshield Adjustment

Measure from the inside edge of the windshield frame to the inside edge of the tailgate. This measurement should be 83-3/4" – 84" or the top will not fit or function properly. If the measurement is slightly more than 84" the tension from the top may pull it into position. If the measurement is less than 83-3/4", loosen the bolts on both sides of the windshield frame, place shims under the frame and re-tighten the bolts.

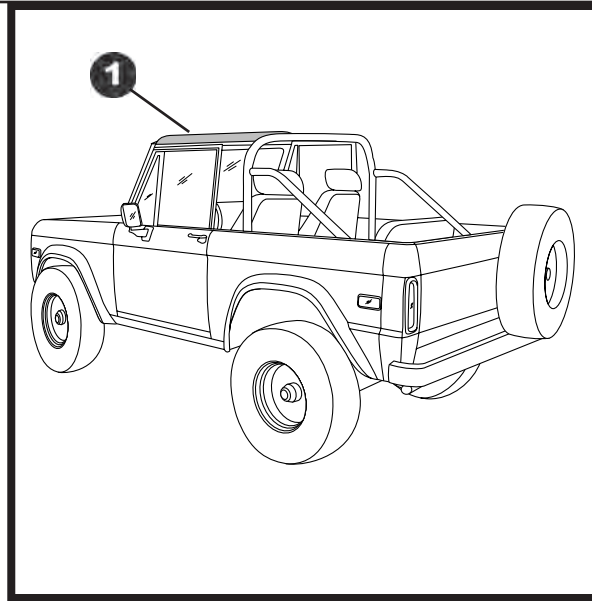
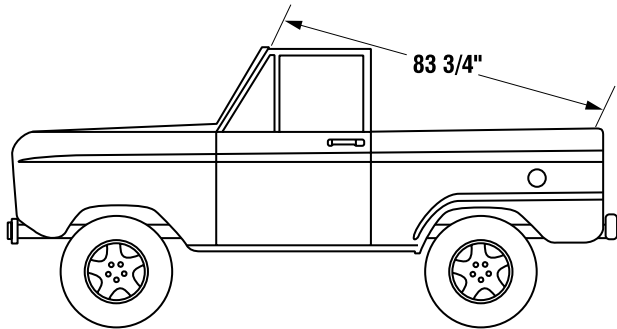
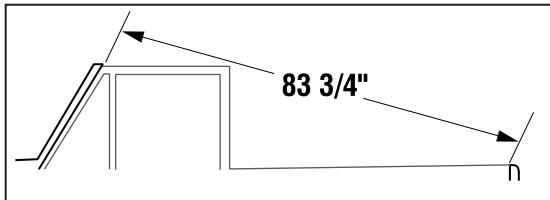

1 Install Windshield Adapter

Orient the two pieces of the Windshield Adapter on the windshield frame with the curve toward the outside of the vehicle and the lip toward the front. Align the holes in the adapter with the holes in the frame. Install a 1/4-20 x 3/4" Pan Head Bolt, a 1/4-20 Hex Lock Nut and two 1/4 x 3/4 OD Flat Washers in each hole.

NOTE If there is any weatherstripping along the top of the windshield frame it should be removed.

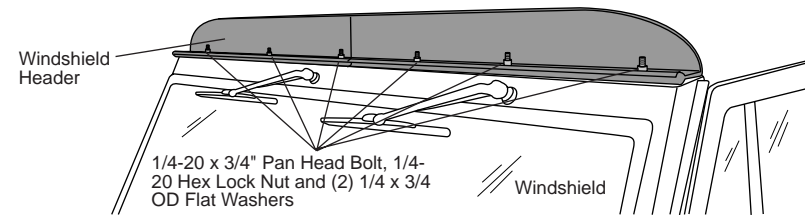

Supertop® – Installation Instructions

2 If Windshield Wiper Motor Cover interferes with Adapter Installation – Optional

If your vehicle has a plastic windshield wiper motor cover that interferes with the installation of the Windshield Adapter you will need to trim the sides of the cover. Remove the cover and use the templates provided to mark the areas to be trimmed. Reinstall the cover.

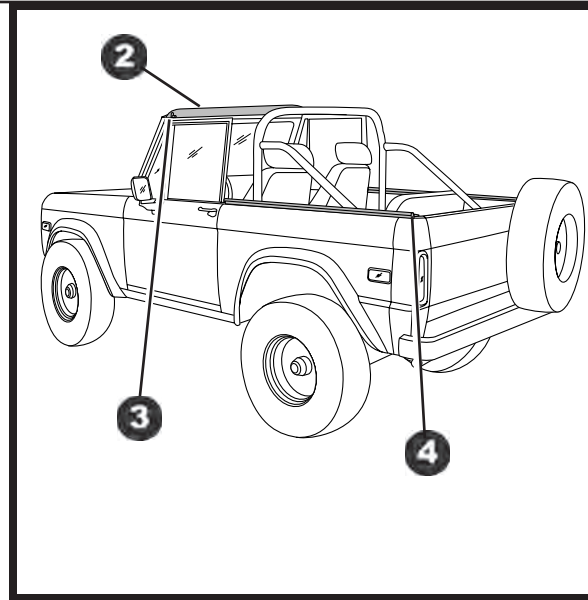
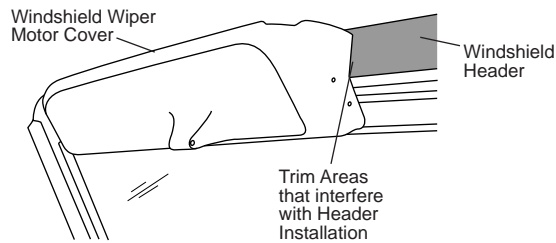

3 Install Windshield Brackets

Locate the Left and Right Windshield Brackets in the parts kit. Align the holes in the brackets with the hole in the Windshield Adapter facing the inside of the vehicle. Center the slots in the brackets over the holes and use two 10-24 x 3/8" Truss Head Screws and two 10-24 Lock Nuts to install each bracket.

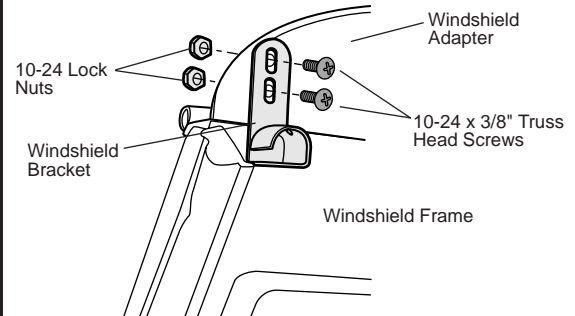

Templates for Windshield Wiper Motor Cover

Cut out the template and position it on the wiper motor cover. Mark the cover along the straight edge of the template. Cut the cover along the line.

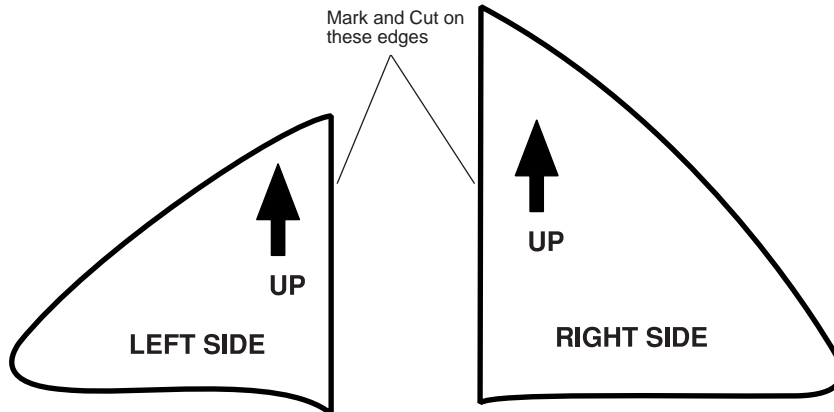

4 Install Side Belt Rails and Tailgate Brackets

Locate the Left and Right Side Belt Rails in the parts kit. Orient them with the bent channel to the outside of the vehicle. Place the belt rails on the top of the sides of the vehicle and align the holes in the rail with the holes in the vehicle. Place the Tailgate Brackets on the rear of the Side Belt Rail with the raised end toward the rear. Align the hole in the bracket with the hole in the belt rail. Install a 5/16-18 x 1" Screw with 5/16" Washer from above and a 5/16" Tapping Plate from under the ledge to secure the rear of the Side Belt Rail and the Tailgate Bracket.

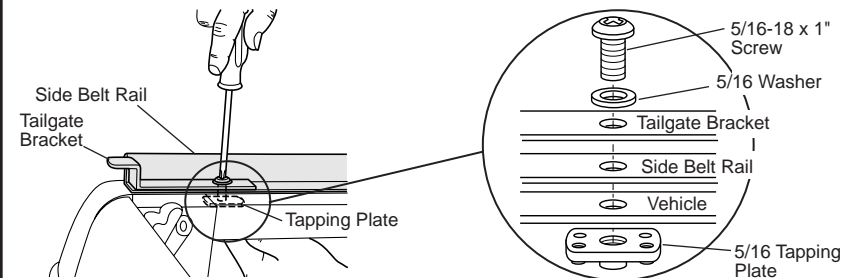

Supertop® – Installation Instructions

5 Install Side Belt Rails and Vertical Rod Mount

Place the Vertical Rod Mount on the front of the Side Belt Rail with the raised end toward the front. Align the hole in the bracket with the hole in the belt rail. Install a 5/16-18 x 1" Screw with 5/16" Washer from above and a 5/16" Tapping Plate from under the ledge to secure the front of the Side Belt Rail and the Vertical Rod Mount.

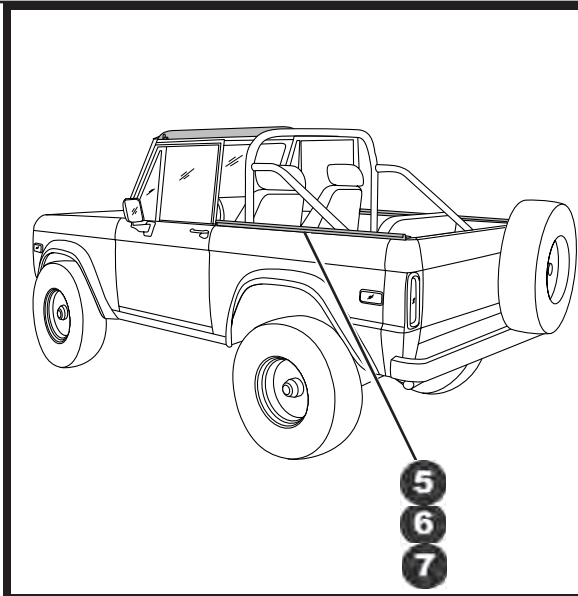
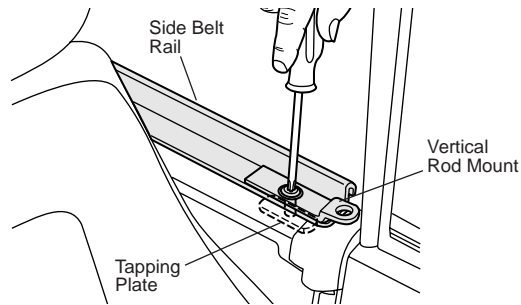

CAUTION Safety Glasses should be worn at all times while installing this product.

7 Install Bow Assembly

Measure 2" toward the front from the fifth hole in the Side Belt Rail. Mark, center punch and drill a 3/16" hole at this location.

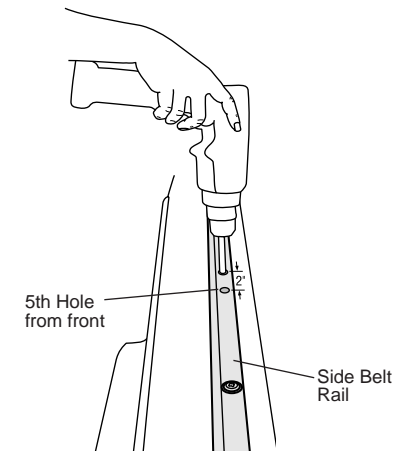

6 Install Side Belt Rails

Install a 5/16-18 x 1" Screw with 5/16" Washer and a 5/16" Tapping Plate in the remaining holes in the Side Belt Rails except the fourth and fifth holes from the front.

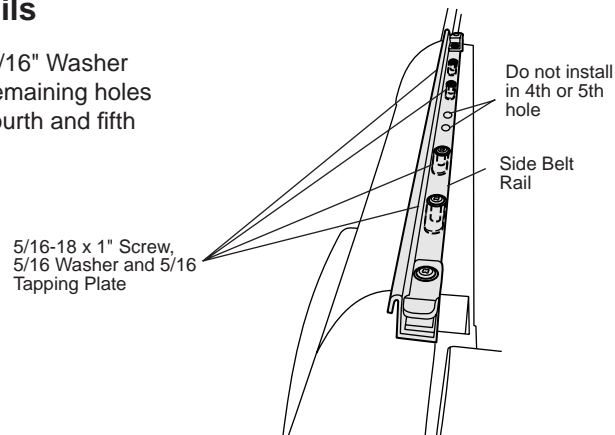

Supertop® – Installation Instructions

8 Install Bow Assembly

Orient the left and right bow assembly halves on the vehicle. Lay the bows down on top of the body. Start the male end of the Top (Front) Bow into the female end. Push the bow halves together until they are fully engaged. Slide the foam pieces on the bow together. Then start the male end of the Bottom (Rear) Bow into the female end and push the bow halves together until they are fully engaged.

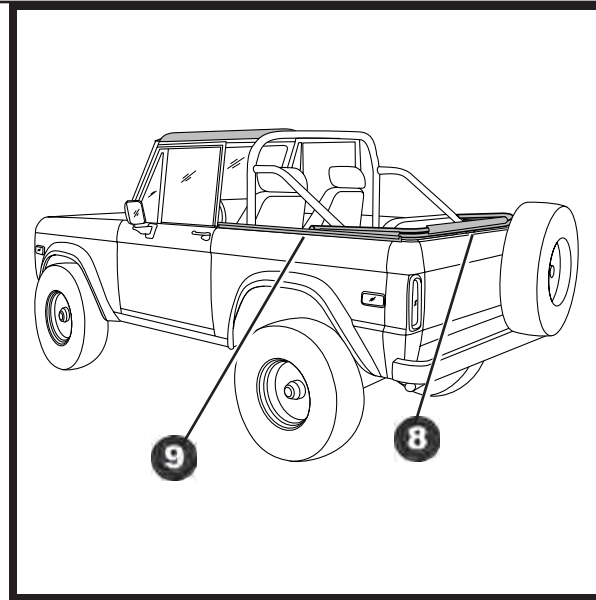
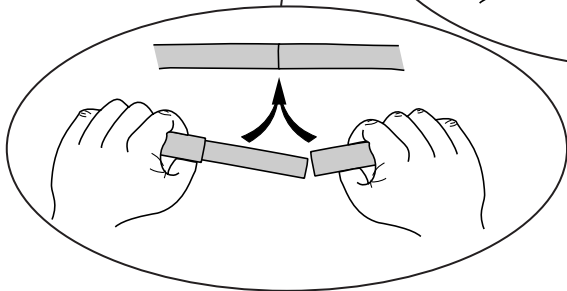
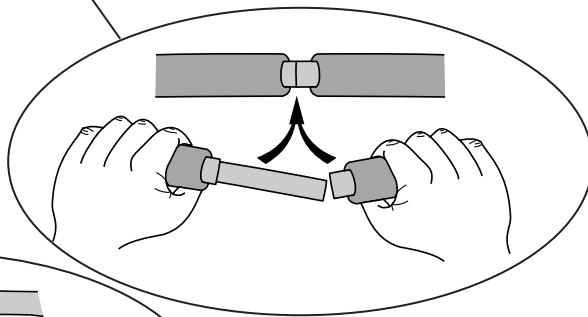
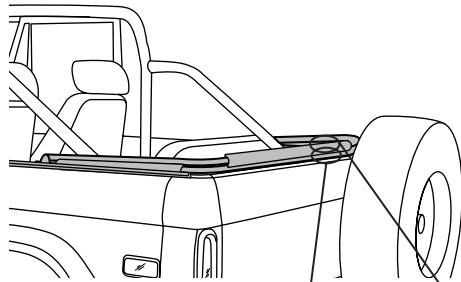

9 Install Bow Assembly

Lay the bows on the rear of the vehicle with the mounts over the remaining holes in the Side Belt Rails. Secure the front hole in the bow mount with a 14 x 1/2" Pan Head Sheet Metal Screw in the hole drilled in the vehicle in Step Seven. Then rotate the bows forward and install a 5/16-18 x 1" Screw with 5/16" Washer and a 5/16" Tapping Plate in the rear hole in the mount.

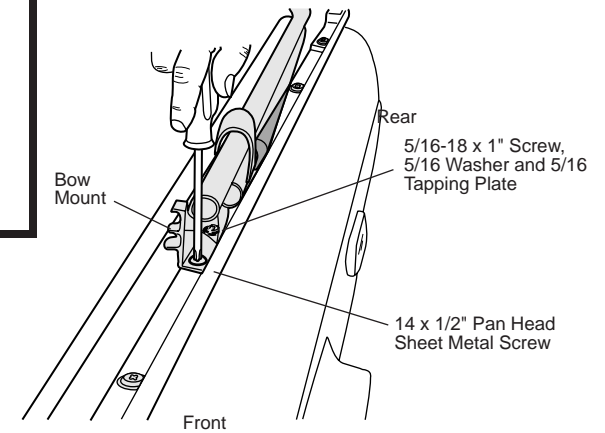

Supertop® – Installation Instructions

10 Install Bow Assembly

Raise the bows and insert the Vertical Rods into the Vertical Rod Mounts installed at the front of the Side Belt Rails.

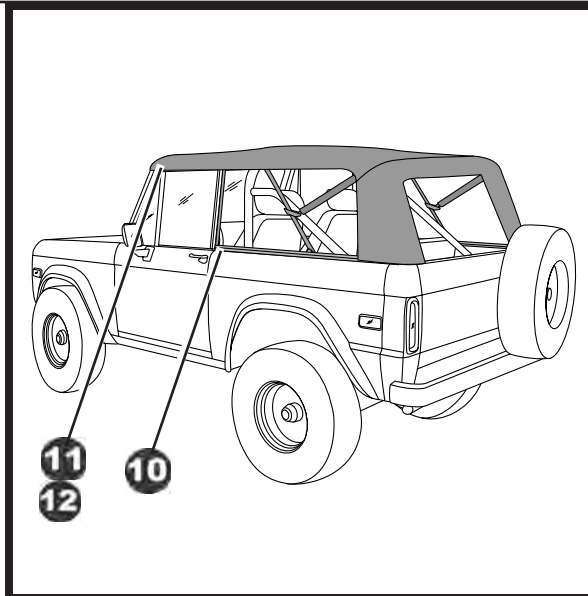
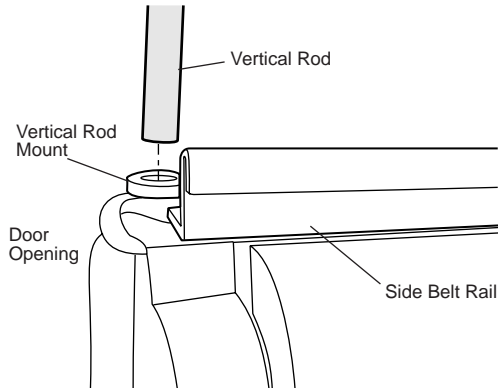

12 Slide Deck into Windshield Adapter Channel

Orient the top with the tube edge toward the front. Lay the fabric on the hood of the vehicle with the vinyl side down and the tubed edge toward the windshield. Start on one side and slide the tubed edge of the fabric into the channel on the Windshield Adapter. Make sure that the fabric is centered on the vehicle.

Flip the fabric back over the Windshield so that it lays vinyl side up over the vehicle.

11 Install Bow Assembly

Insert the Horizontal Rods into the Windshield Brackets installed in Step Three. Push down on the rear button of the retaining clip and slide the rod into the bracket. Release the button once the rod is in position to lock it in place.

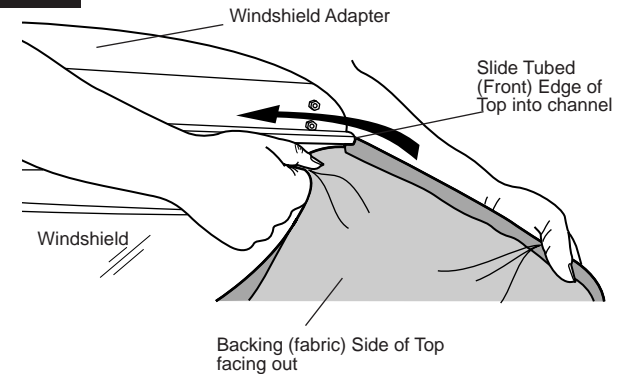
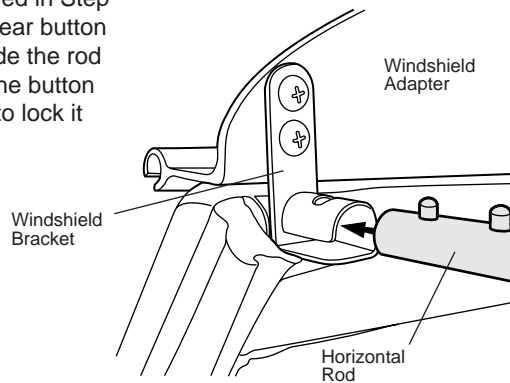

Supertop® – Installation Instructions

13 Snap to Windshield

Snap the corners of the Top to the studs on each side of the windshield frame.

NOTE If your vehicle does not have snaps on the windshield frame, rub chalk on the snaps on the inside of the top to mark the stud locations. Press the snaps against the body. The chalk will leave marks for the Body Stud locations. Center punch the marks and drill a 3/32" hole at each marked location. Install a Body Stud with a #6 x 3/8" Sheet Metal Screw at each location. Snap the top to the studs.

If your vehicle already has snaps on the windshield frame, they may need to be relocated. The position of the snaps may fit a previous top that was not a Bestop® top.

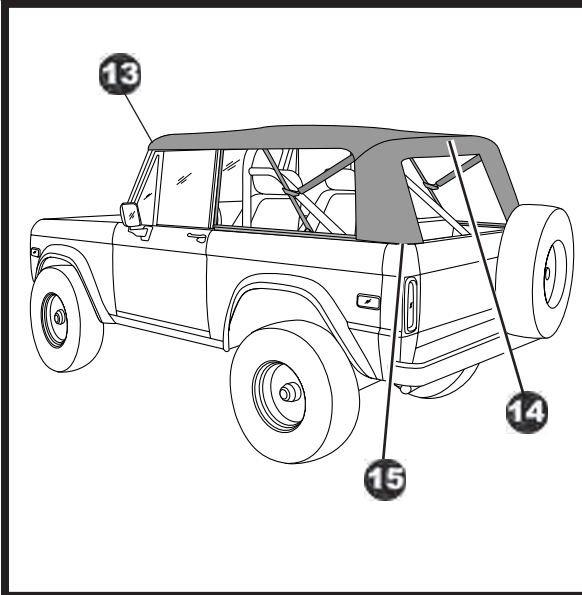
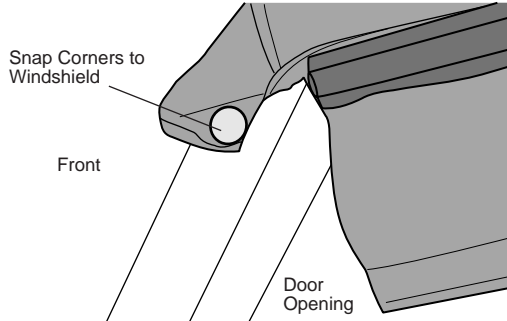

14 Snap to Rear Bow

Pull the top fabric back over the rear of the vehicle. Slide the Rear Bow into the fabric above the rear window opening until the rear seam fits around the bow. Pull the six snap tabs around the bow from the rear and snap them to the bow.

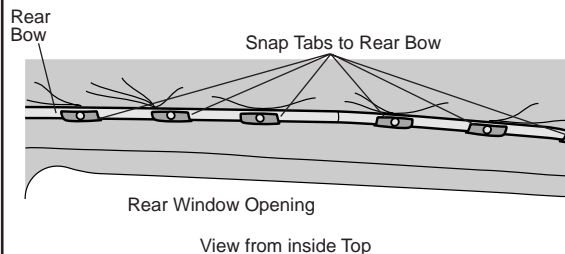

15 Hook Corner Retainers into Side Belt Rail

Locate the plastic retainer strip sewn into the bottom of the rear legs of the top. Slip the strip into the channel on the Side Belt Rail on each side of the vehicle. Align the end of the plastic with the top of the Tailgate Bracket.



Slip Plastic Retainer into Channel in Side Belt Rail

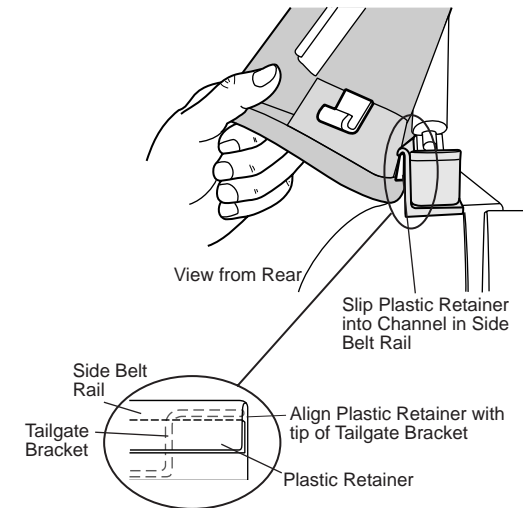

Supertop® – Installation Instructions

16 Slide Rear Bow into Position

Reach in under the Quarter Window opening and carefully slide the Rear Bow up on the Front Bow to increase the tension on the top. Insert the pin in the slide into the lowest of the three holes in the Front Bow.

NOTE The top will loosen up after a few hours in the sun. Then the pin may be inserted into a higher hole position.

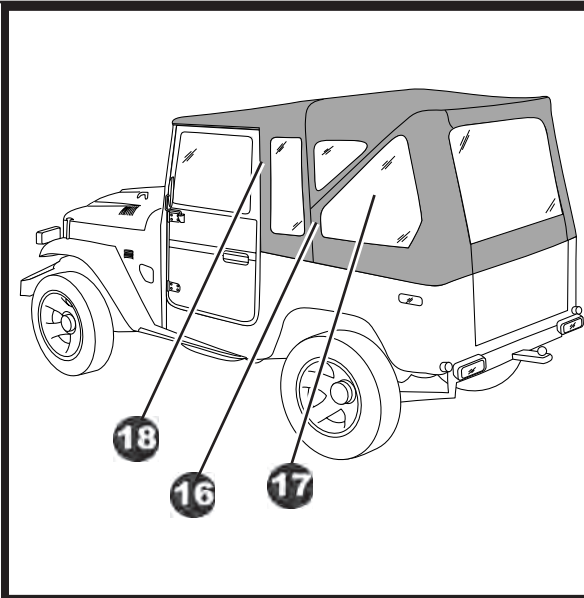
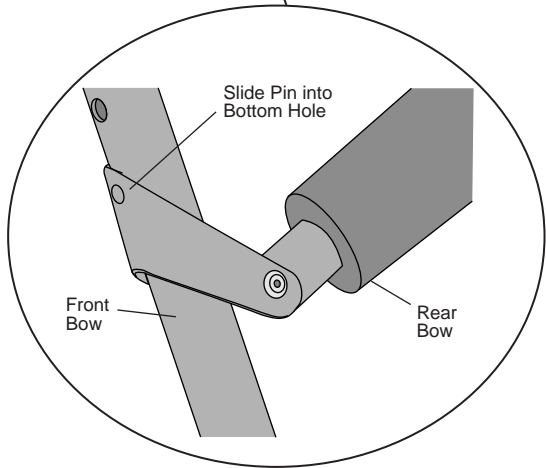
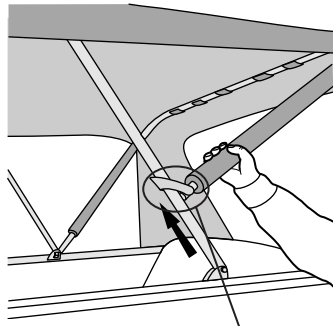

17 Install Quarter Windows

Orient the Quarter Windows with the zippers to the top and rear of the panel. Start the top zipper and close it 3" then start the rear zipper. Close both zippers completely. Slip the plastic retainer strip along the bottom of the panel into the channel in the Side Belt Rail. Fasten the Hook and Loop Strips at the rear of the panel.

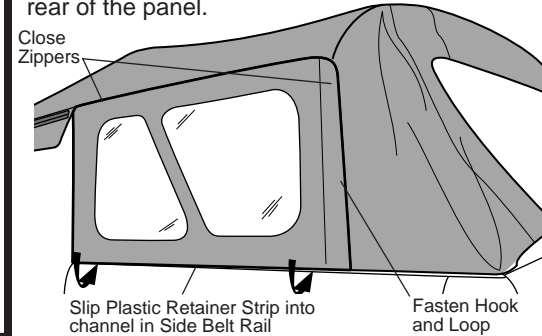

18 Secure Top and Quarter Window Flaps

Locate the flap along the front of the Quarter Window and wrap it around the Vertical Rod. Fasten the hook and loop on the flap and inside the panel. Then wrap the flap above the door opening around the Horizontal Rod and fasten the hook and loop on the flap and inside the top. Fasten the hook and loop tabs around the center bow to secure the window panel.

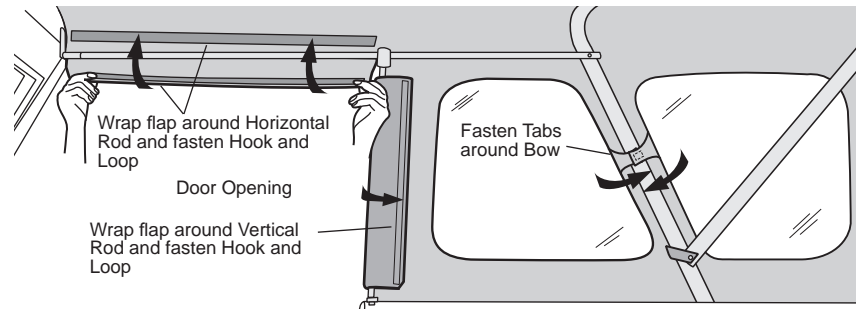

Supertop® – Installation Instructions

19 Install Rear Window

Open the tailgate and orient the Rear Window with the zippers toward the top and the vinyl side out. Zip the window to the Top. Close the top zipper completely and closing the side zippers about 3".

Orient the Tailgate Retainer with the rubber bulb facing down and the tube channel facing out. Slide the retainer onto the tube strip sewn to the inside of the window. Push the ends of the flat channel onto the Tailgate Bracket on each side of the tailgate opening.

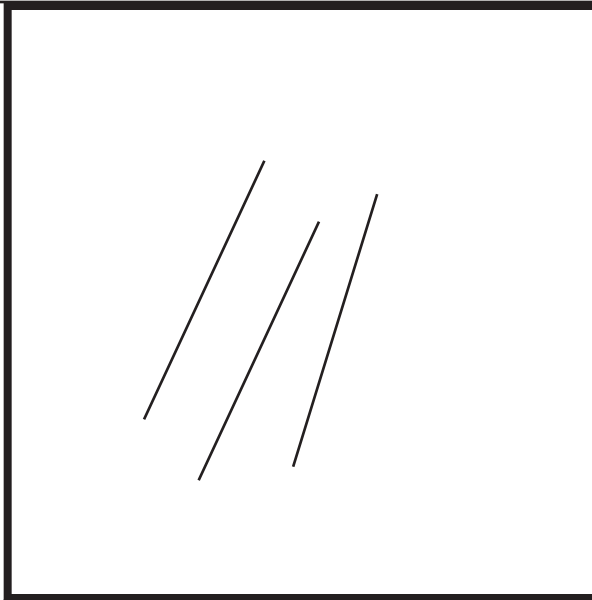
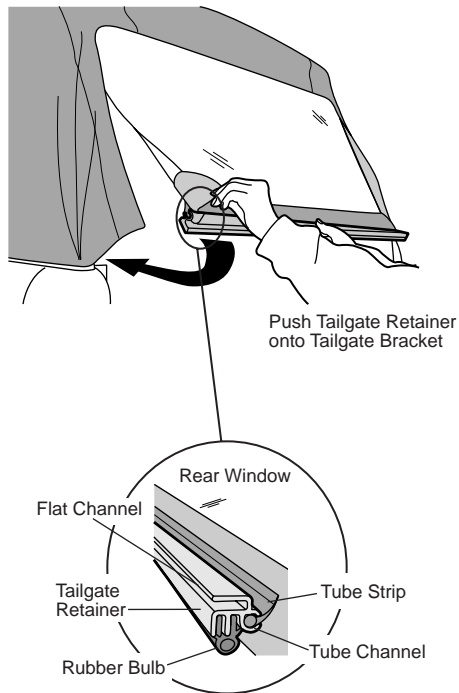

20 Install Rear Window

Close the side zippers completely on the Rear Window. Hook the plastic clip sewn inside the rear corner of the top to the Tailgate Bracket. Fasten the hook and loop strips sewn on the Rear Window and inside the rear corner of the top.

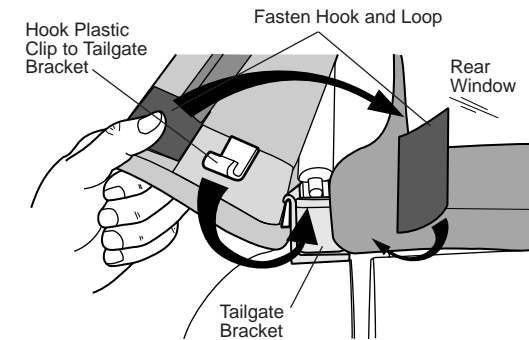

Without Rear Window

If you choose not to install the Rear Window at this time, please secure the back frame of the deck to prevent it from flapping in the wind. Fasten the loop sewn to the rear corner of the top to the hook sewn to the inside reinforcement.

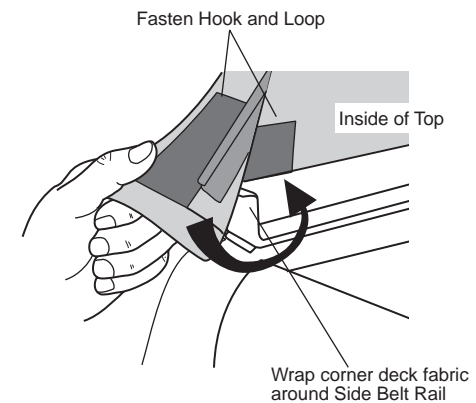

Supertop® – Installation Instructions

Care and Maintenance of your Bestop Product

Your Bestop product is made of the finest materials available. To keep it looking new and for the maximum possible wear, it will need periodic cleaning and maintenance.

Washing: The fabric should be washed often using soap, warm water and a soft bristle brush. Rinse with clear water to remove all traces of soap or use Bestop-recommended Bestop Cleaner and Bestop Protectant. Bestop Cleaner and Bestop Protectant are specially formulated to provide a total cleaning and protection system. Bestop Cleaner will not harm vehicle finish, is biodegradable and environmentally friendly. Bestop Protectant protects against UV-fading, cracking and hardening.

Windows: Keep windows clean to avoid scratching. DO NOT use a brush on the windows! Wash with a water-soaked cloth or sponge and a mild dishwashing detergent or use Bestop-recommended Bestop Vinyl Window Cleaner, which safely cleans and protects vinyl windows while helping prevent UV damage. NEVER WIPE THE WINDOWS WHEN THEY ARE DRY. Be careful when cleaning snow or frost from the vinyl windows since they are easily scratched and may crack at low temperatures. DO NOT roll the sides or rear window in cold weather. The windows become stiff and will crack.

Zippers: Keeping the zipper cleaned and lubricated with a silicone lubricant will help prevent damage and keep the zippers in a smooth working condition. If a zipper opens behind the slider, the slider may have been spread apart. This problem can usually be repaired by using an ordinary pair of pliers to bring the sides back into parallel. Return slider to the end of the zipper in the normal Open position. Squeeze lightly at first and test the zipper. If the zipper continues to remain open squeeze more firmly with the pliers and try the zipper again. Repeat this procedure until the zipper operates correctly.

Water: Seeping through at the seams may be stopped by applying 3-M Scotchgard® on the inside of the seams. Rips in the fabric may be repaired with Bondex® iron on patches. Iron the patches to the Inside of the top, carefully following the Bondex® instructions.

Snaps: Keep snaps cleaned and lubricated with silicone to help prevent snaps from sticking to the studs. If a snap does become stuck to a stud, use a screwdriver and GENTLY pry apart to prevent permanent damage to the snap or the top fabric.

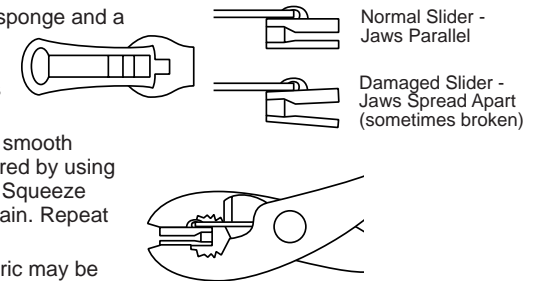

LIMITED WARRANTY

We warrant our product to be free from defects in material and workmanship, for the terms specified below, provided there has been normal use and proper maintenance. This warranty applies to the original purchaser only. All remedies under this warranty are limited to the repair or replacement of any item or items found by the factory to be defective within the time period specified. If you have a warranty claim, first you must call our factory at the number below for instructions. You must retain proof of purchase and submit a copy with any items returned for warranty work. Upon completion of warranty work, if any, we will return the repaired or replaced item or items to you freight prepaid. Damage to our products caused by accidents, fire, vandalism, negligence, misinstallation, misuse, Acts of God, or by defective parts not manufactured by us, is not covered under this warranty.

THE WARRANTY TIME PERIOD IS AS FOLLOWS FOR REPLACE-A-TOP™, SAILCLOTH REPLACE-A-TOP™, SUPERTOP®, SUPERTOP® REPLACEMENT SKINS, SUNRIDER®, AND TIGERTOP®: TWO YEARS FROM DATE OF PURCHASE.

THE WARRANTY TIME PERIOD IS AS FOLLOWS FOR ALL OTHER "SOFT GOODS" MANUFACTURED BY OUR COMPANY (USING PRIMARILY VINYL, PLASTICS, AND/OR FOAM): ONE YEAR FROM DATE OF PURCHASE.

THE WARRANTY TIME PERIOD IS AS FOLLOWS FOR ALL OTHER "HARD GOODS" MANUFACTURED BY OUR COMPANY (USING PRIMARILY METALS, PLASTICS, AND/OR FIBERGLASS): ONE YEAR FROM DATE OF PURCHASE.

ANY IMPLIED WARRANTIES OF MERCHANTABILITY AND/OR FITNESS FOR A PARTICULAR PURPOSE CREATED HEREBY ARE LIMITED IN DURATION TO THE SAME DURATION AND SCOPE AS THE EXPRESS WRITTEN WARRANTY. OUR COMPANY SHALL NOT BE LIABLE FOR ANY INCIDENTAL OR CONSEQUENTIAL DAMAGE.

Some states do not allow limitations on how long an implied warranty lasts, or the exclusion or limitation of incidental or consequential damages, so the above limitations or exclusions may not apply to you. This warranty gives you specific legal rights, and you may also have other rights which vary from state to state.



For further information or request for warranty work, please contact:

Bestop Inc., Customer Service
Toll-Free: (800)845-3567
Main: (303)465-1755
E-mail: csbestop@Bestop.com
Website: www.Bestop.com