





Installation Instructions Sunrider®











Vehicle Application

• Jeep CJ7
1976 – 1986
Part Number: 51698

• Jeep Wrangler/YJ
1986 – 1995
Part Number: 51698

www.Bestop.com - We're here to help! Visit our web site and click on "Ask a Question". Click here for more [Jeep Accessories by Bestop](#).

INSTALLATION TIME	SKILL LEVEL
	
3 Hours	3 - Moderately Difficult

TOOLS			
 1/8", 5/32", 7/32" and 3/8"		 #20, #40 and #45	
			
 10'			



 **CAUTION** Safety glasses should be worn at all times while installing this product.

Installation Tips

Before you begin installing this assembly, read all instructions thoroughly.

For a smooth fit:

For ease in installation, the product should be installed at temperatures above 72° F. Below this temperature, the fabric may contract an inch or more, making it difficult to fit to the vehicle. It is normal for fabric to contract and wrinkle when stored in the shipping carton. Within a few days after the installation, the fabric will relax and the wrinkles will disappear.

 **WARNING** This product is designed primarily to enhance the appearance of the vehicle and to shield the occupants from ordinary weather conditions. Do not rely in any way on the components of this product to contain occupants within the vehicle, or to protect against injury or death in the event of an accident. This product will not protect the occupants from falling objects. Never operate the vehicle in excess of manufacturer's specifications.

WEAR SEAT BELTS AT ALL TIMES

Read and follow, precisely, all installation instructions provided when installing product. Failure to do so may result in a poor fit and could place occupants of the vehicle in a potentially dangerous situation.

Sunrider® – Installation Instructions

Top Fabric	Qty - 1
Quarter Window, Right	Qty - 1
Quarter Window, Left	Qty - 1
Rear Window	Qty - 1
Windshield Header Trim	Qty - 1

Parts List and Hardware Identification

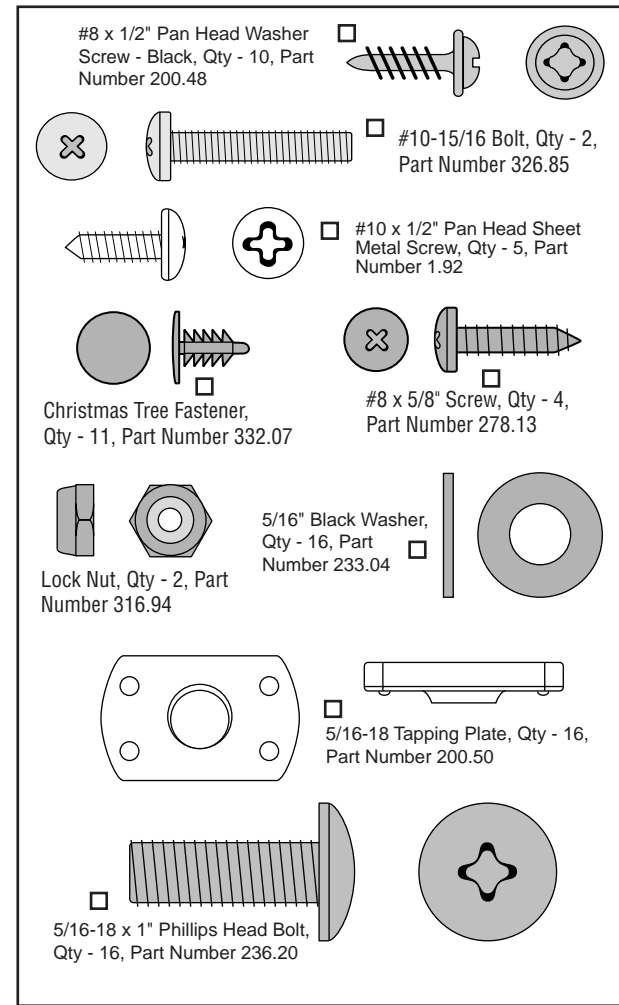
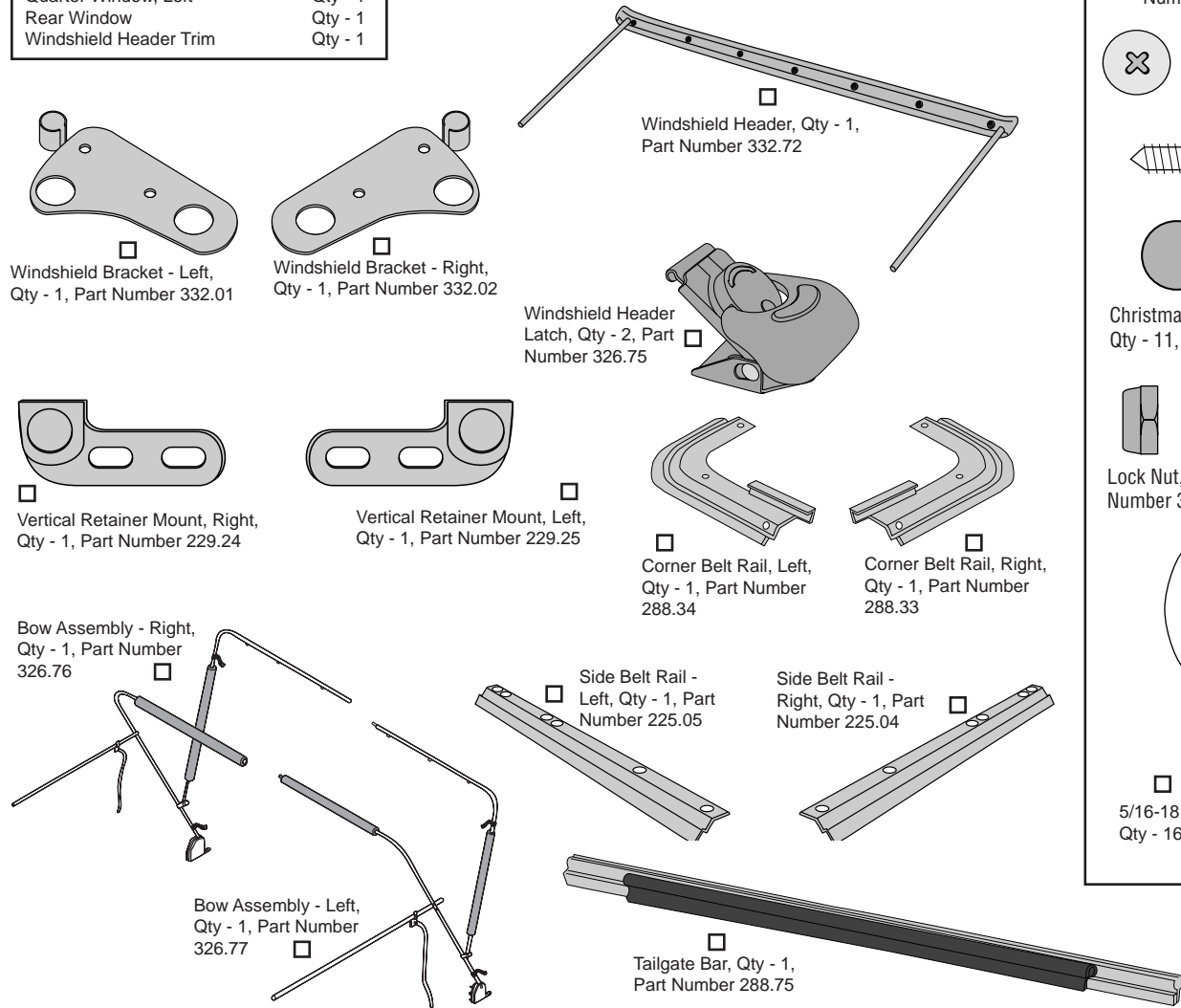

Sunrider® – Installation Instructions

NOTE If you are replacing an old soft top, be certain that all parts of the old top are removed, including the windshield retainer. Old metal parts are not compatible with the new Supertop. Using parts other than those provided in your Supertop kit can result in personal injury and/or damage to the vehicle and soft top.

WARNING Improper windshield adjustment will result in poor fitting top and doors, causing looseness or undue strain on the top.

CJ7 Windshield Measurement

Before installing the top, check the windshield measurement. The distance from the top lip of the windshield to the top outer edge of the body must be 75 1/8" on both sides of the vehicle. Measure from 6" inside the doors.

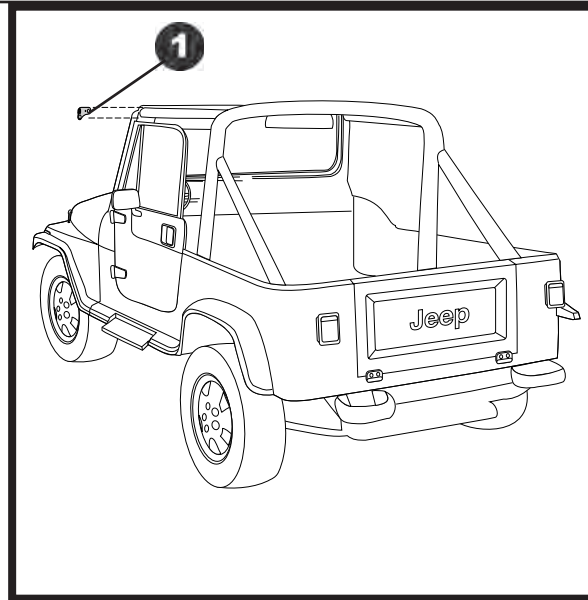
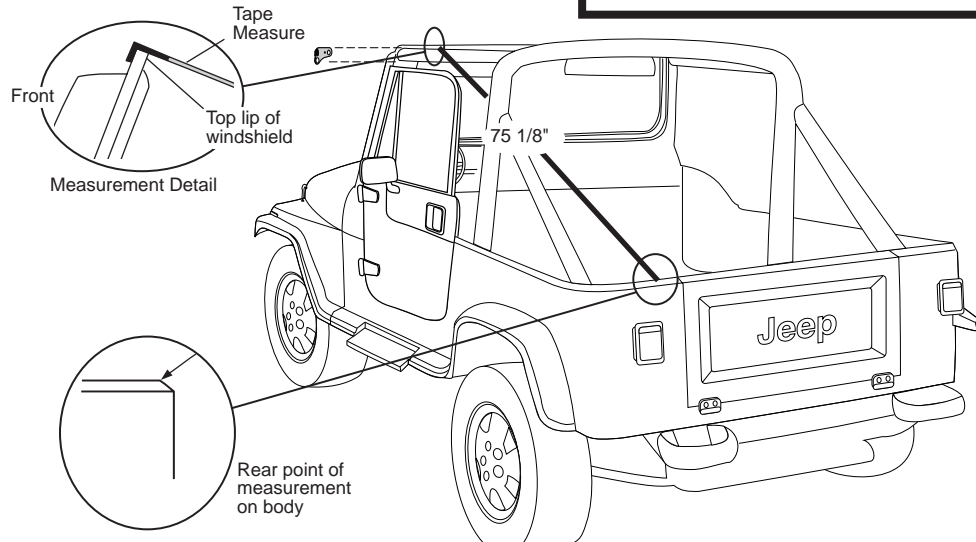

1 Install Windshield Brackets – CJ7 Only

After adjusting the windshield, install the Windshield Brackets. If present remove the outboard sun visor fasteners on both sides of the windshield frame. Place the Windshield Brackets flush with the frame on the upper corners of the windshield. Use the bracket as a template to mark, center punch and drill two 5/32" holes for each bracket. Mount each bracket to the windshield frame using two #10 x 1/2" Pan Head Sheet Metal Screws. Reinstall sun visor brackets.

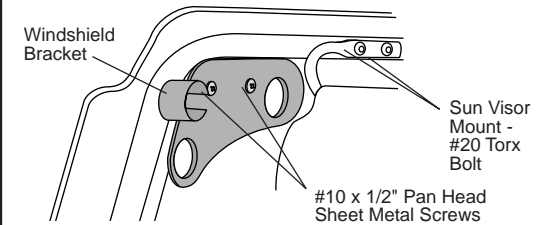

CJ7 Windshield Adjustment: If necessary, loosen the two screws in the Windshield Clamps at the base of the windshield on each side of the vehicle. Adjust the windshield forward or back, use a shim if needed to position the windshield, and tighten the screws.

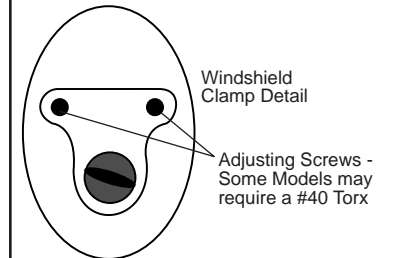

Sunrider® – Installation Instructions

NOTE Under most circumstances, the windshield of the Wrangler will not require any adjustment. If your Wrangler windshield should require adjustment, this adjustment should be performed only by an authorized automotive mechanic using a special "Tamper-Proof" Torx head tool.

WARNING Improper windshield adjustment will result in poor fitting top and doors, causing looseness or undue strain on the top.

Wrangler Windshield Measurement

Before installing the top, check the windshield measurement. The distance from the top lip of the windshield to the top outer edge of the body must be 75 1/8" on both sides of the vehicle. Measure 4"-6" inside the doors.

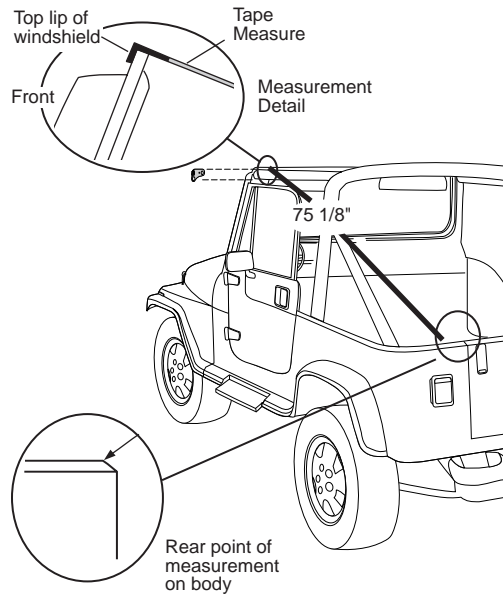

Wrangler/YJ Windshield Adjustment: If necessary, loosen the #40 TORX bolts in the windshield clamps to loosen the windshield in order to slip the bracket under the horizontal tube.

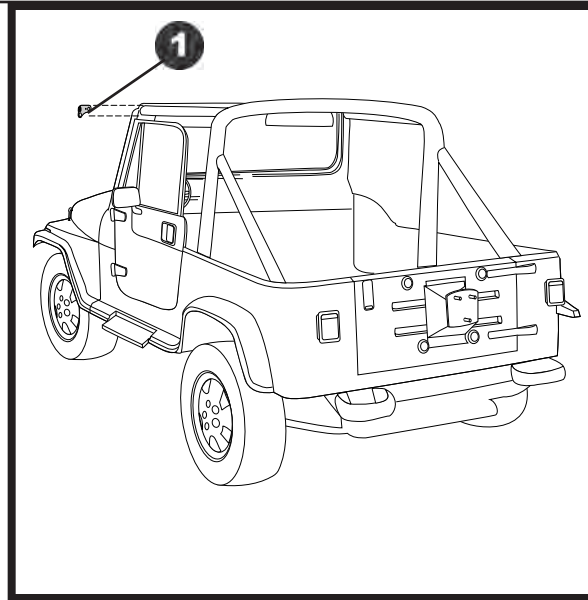
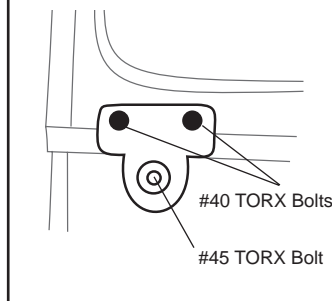

WARNING Reinstall the bolts that secure the Horizontal Sport Bars to the windshield with a torque of 17.0 ft. lbs. each. If you do not have a torque wrench these bolts should be tested by a qualified mechanic using a torque wrench. Failure to tighten and test the torque of these bolts can result in personal injury or loss of life to the driver and occupants of the vehicle in the event of an accident.

1 Install Windshield Brackets – Wrangler/YJ Only

Use a #20 Torx to remove the outboard sun visor fasteners on both sides of the windshield frame. Remove the two #40 Torx head bolts that secure the horizontal sport bar to the windshield frame. Slide the Windshield Brackets between the windshield and the horizontal sport bar mounts.

Reinstall the Torx head bolts, starting each in the frame with your fingers. After the Torx head bolts are started by hand tighten with your ratchet and Torx drive tool. Do not lay this tool aside until both bolts are completely tightened. If you tighten one of these bolts and the telephone rings - LET IT RING. NEVER LAY THIS TOOL ASIDE OR INTERRUPT THIS PROCEDURE. This procedure should be followed carefully on both sides of the vehicle.

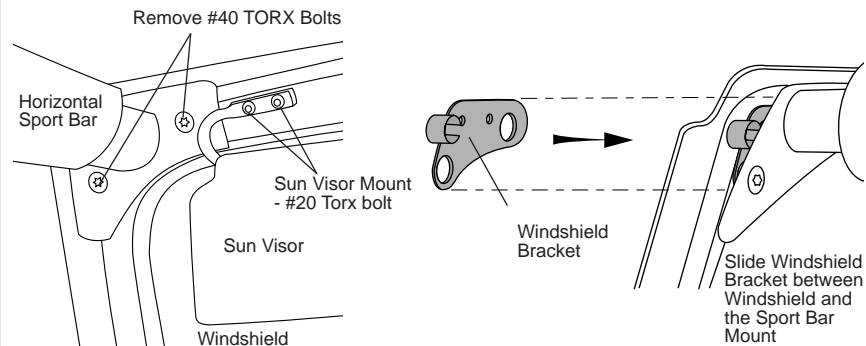

Sunrider® – Installation Instructions

2 Install Christmas Tree Fasteners

If you have removed an old Bestop top and windshield retainer, install a Christmas Tree Fastener in each hole in the windshield frame.

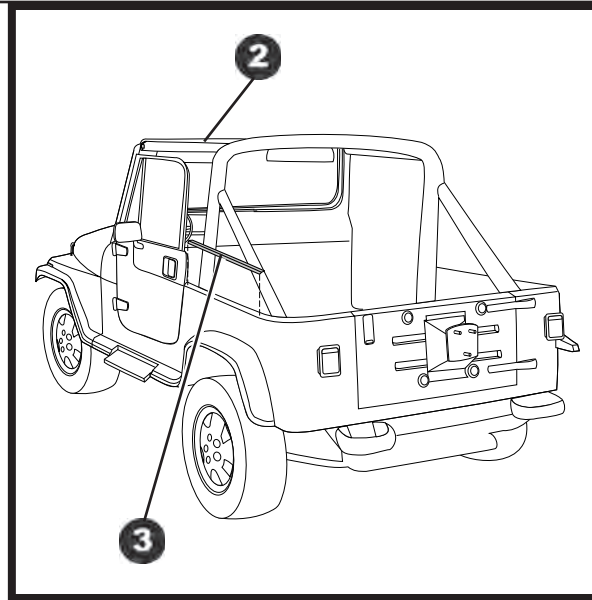
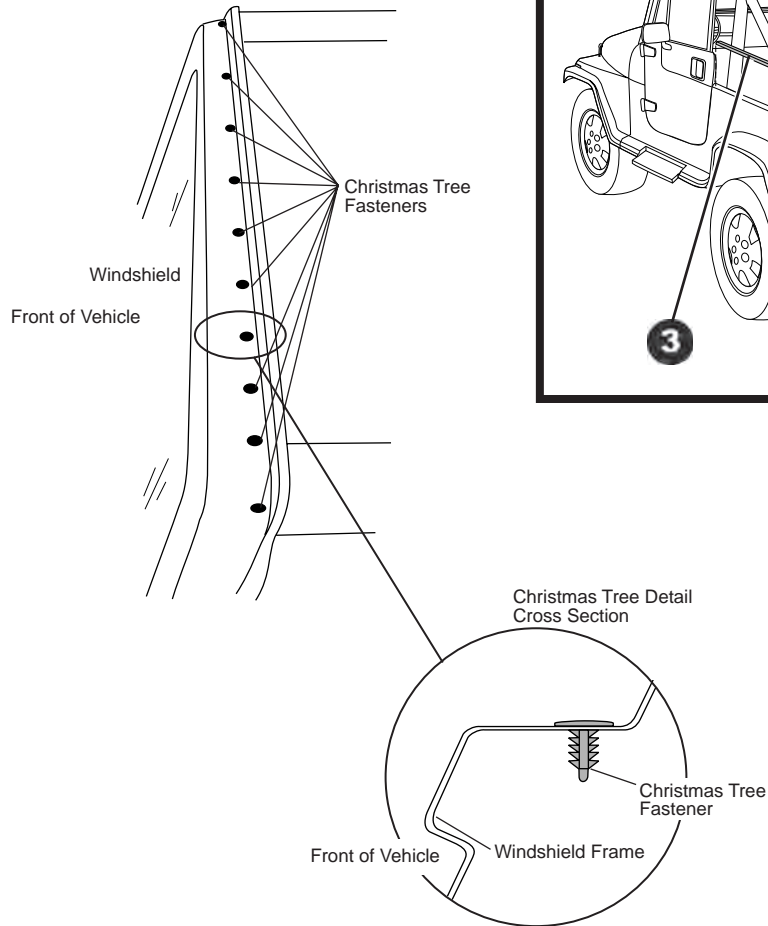

CAUTION

When drilling in the top edge of the vehicle body, check underneath for wiring for the rear lights. Pull the wiring out of the way before drilling.



3 Install Side Belt Rails

Install the Left and Right Side Belt Rails on each side of the vehicle. Use the Belt Rails as templates to mark, center punch and drill six 3/8" holes along the top edge of the body on each side of the vehicle. Secure the two rear holes in the rails with two 5/16" Phillips Head Bolts, two 5/16" Washers and two 5/16" Tapping Plates. Do not tighten the bolts yet.

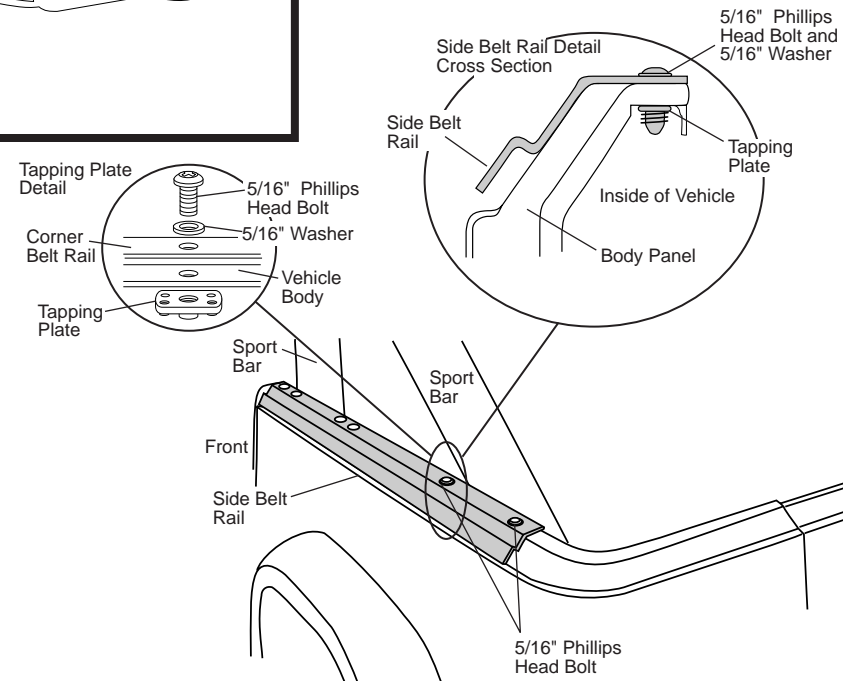

Sunrider® – Installation Instructions



CAUTION

When drilling in the top edge of the vehicle body, check underneath for wiring for the rear lights. Pull the wiring out of the way before drilling.



4 Install Rear Corner Belt Rails

Install the Left and Right Rear Corner Belt Rails on each side of the vehicle. Notice that the Corner Belt Rails do not butt-up against the Side Belt Rails installed in Step 3, this is normal. Use the Corner Belt Rails as templates to mark, center punch and drill two 3/8" holes in the top edge of the vehicle body. Some vehicles may already have some of these holes. Install the Corner Belt Rails with two 5/16" Phillips Head Bolts, two 5/16" Washers and two 5/16" Tapping Plates. At the location of the remaining hole in the Corner Belt Rail, next to the tailgate, mark, center punch and drill a 1/8" hole. Install a #8 x 1/2" Pan Head Screw. **Do not tighten the bolts yet.**

NOTE

There may be a small gap of +/- 1/4" between the Corner Belt Rails and the Side Belt Rails.

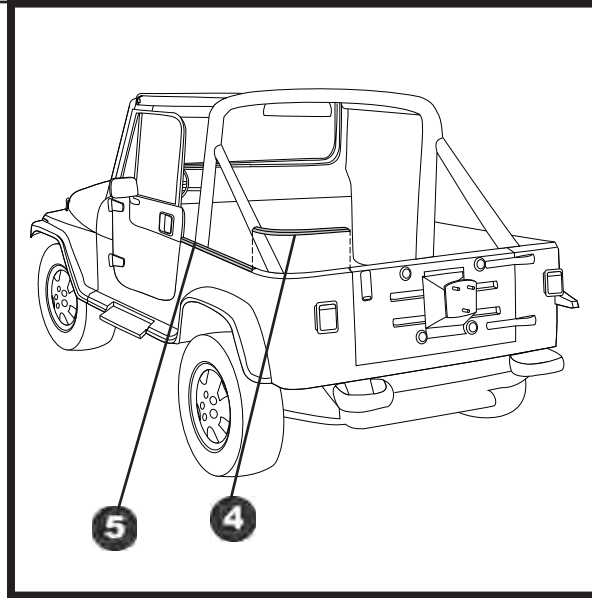
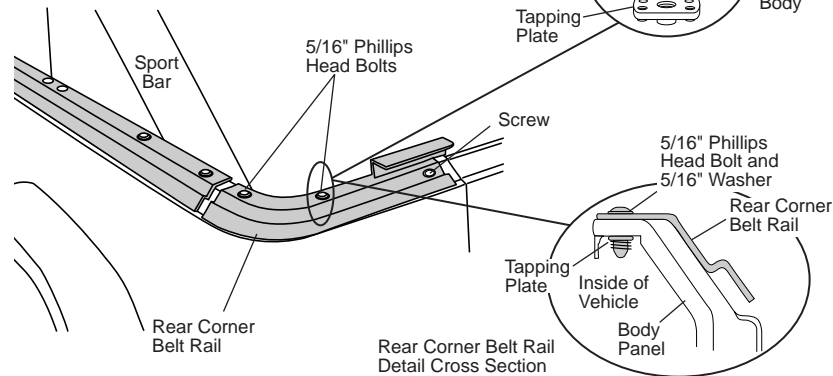

5 Install Vertical Retainer Mounts

Install the Vertical Retainer Mounts on top of the Side Belt Rails, just behind the door openings. Secure them in place with two 5/16-18 x 1" Phillips Head Bolts, two 5/16" Washers and two 5/16" Tapping Plates. Do not tighten the bolts yet.

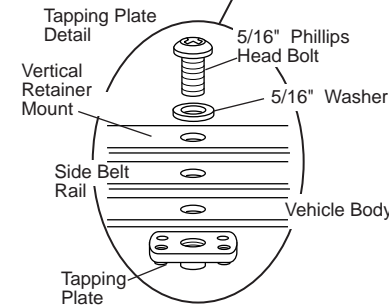
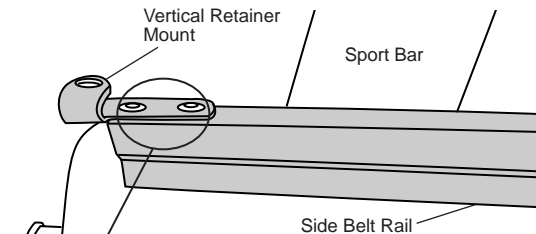

Sunrider® – Installation Instructions

6 Install Bow Assembly

Lay the bow halves on top of the body with the holes in the Bow Mounts over the third and fourth holes in the Side Belt Rails.

It is important that the white packaging tape remain on the bow assemblies until the forward bolt is tightened on both sides.

Secure the FRONT hole in the Bow Mount with a 5/16-18 x 1" Phillips Head Bolt, a 5/16" Washer and a 5/16" Tapping Plate. Once the front hole is secure, cut the packing tape.

Start the male end of the Top (Front) Bow into the female end. Push forward on the bow until the two sides snap together. Slide the foam pieces on the bow together.

Once the Bow Mounts are secure, tighten all of the bolts on the Belt Rails.

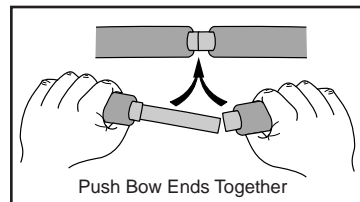
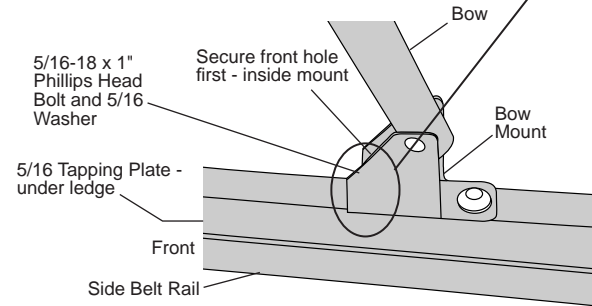
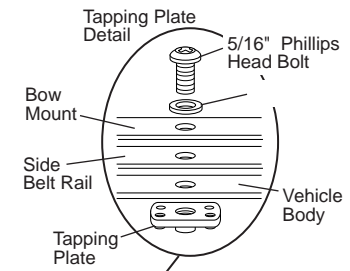
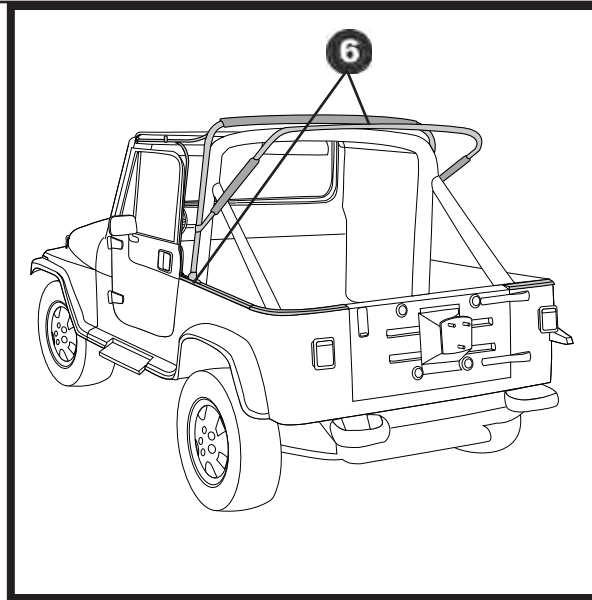

Sunrider® – Installation Instructions

7 Install Bow Assembly

Release the small metal rods from the plastic clips on both sides of the vehicle.

Lift the Top (Front) Bow and start the male end of the Bottom (Rear) Bow into the female end. Push forward on the bow until the two sides snap together.

Slide the Bottom (Rear) Bow up on the Top (Front) Bow to access the rear bolt position in the Bow Mount. Install and tighten the rear bolt in the Bow Mount on both sides of the vehicle.

Raise the Top (Front) Bow Assembly, holding the small rods in an upright position, and insert the Vertical Rods into the hole in the Vertical Retainer Mount. Slip the end of the Horizontal Rod into the tube on the Windshield Bracket until the spring button on the rod pops up through the Windshield Bracket.

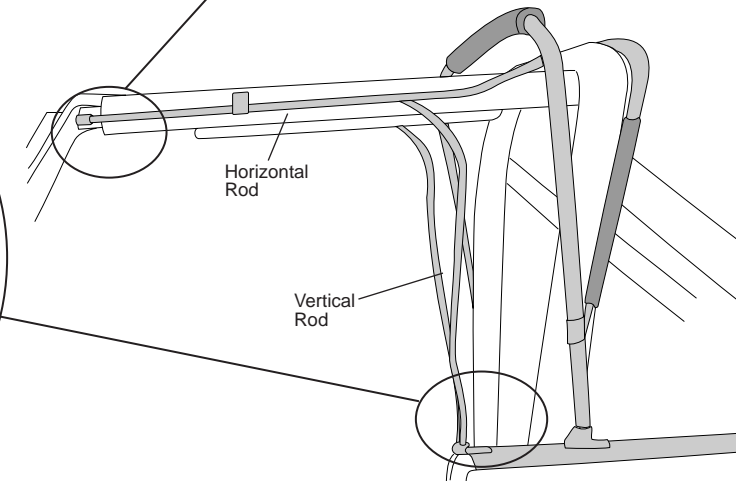
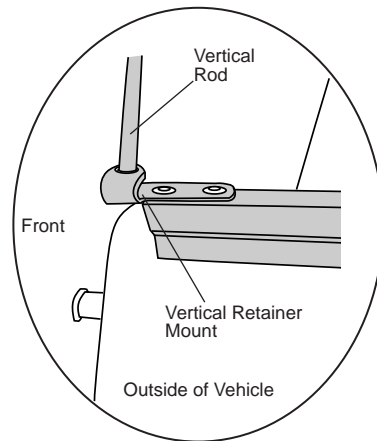
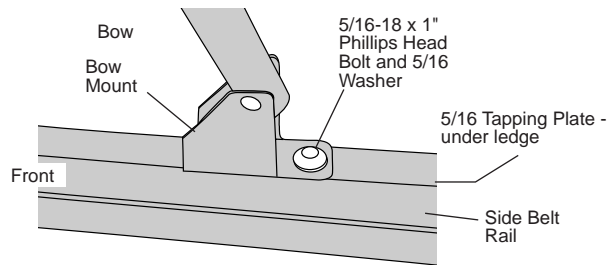
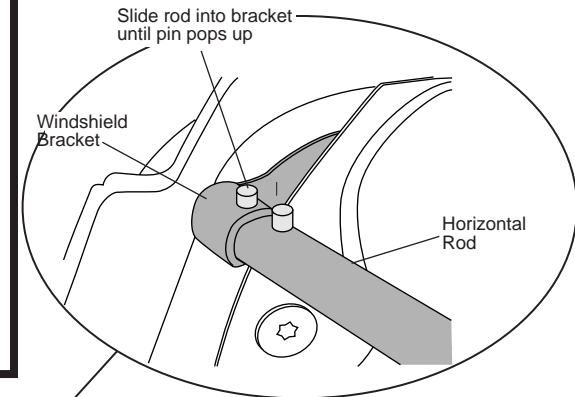
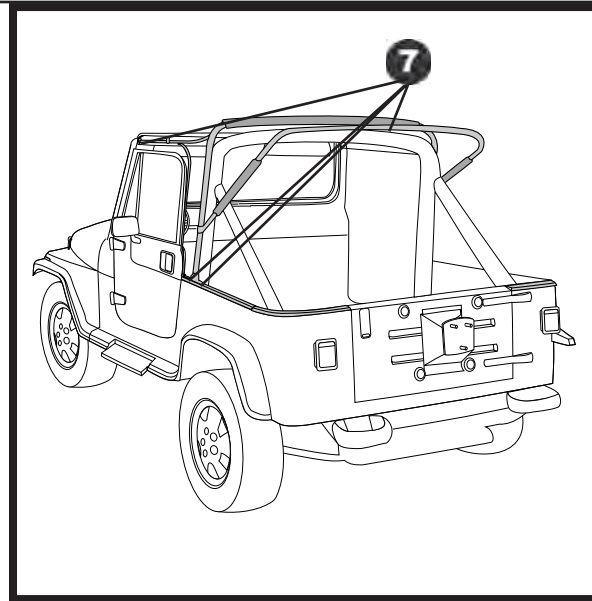

Sunrider® – Installation Instructions

8 Install Windshield Header

Orient the Windshield Header on the vehicle. Lay the header on top of the bows with the snap studs facing up. Place the legs of the header into the bracket above the door opening on each horizontal rod. Install the legs in the brackets with a #10-15/16 Bolt and Lock Nut on each side.

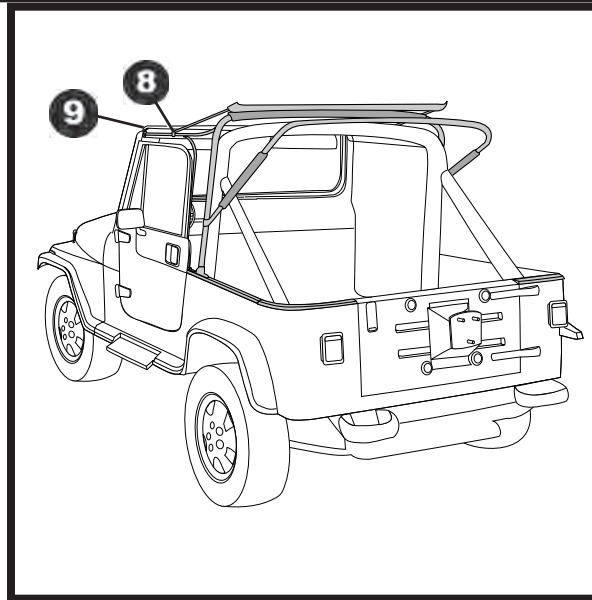
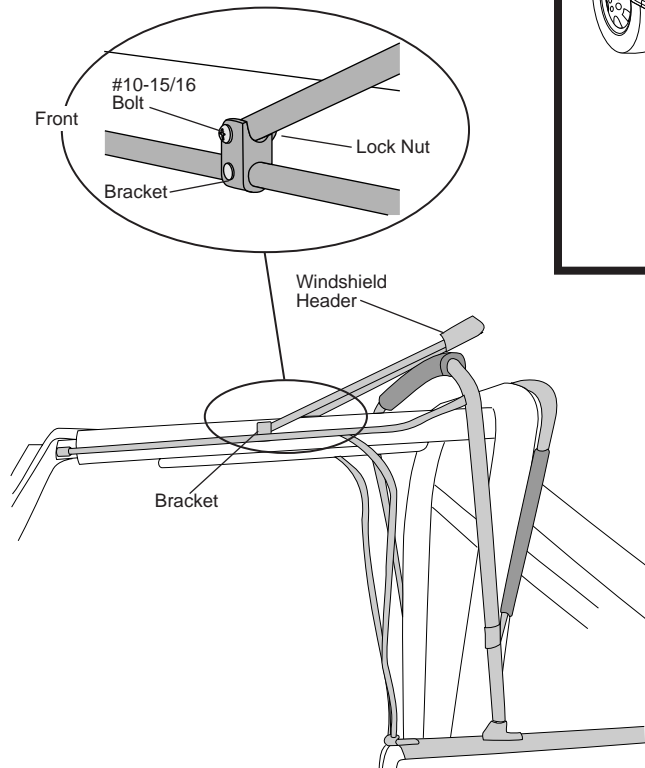

! WARNING

Improper Latch installation will result in a poor fitting Header that could rattle or release under driving conditions.

9 Install Windshield Header Latches

Rotate the Windshield Header down onto the top of the windshield.

Locate the two Windshield Header Latches in the parts kit. Make sure that the latches are in the closed position. Hook each latch in the slots in the Windshield Header. Pull Header down flat on the windshield. Pop the lever out into the horizontal position and mark the location of the bottom hole in the latch. Remove the latch from the slot and spring the body of the latch out so that it is horizontal to the base and so that you can access the top mounting hole. Place the latch back in position with the bottom hole over the mark on the windshield and mark the location of the top hole. Remove the latch, center punch the marks and drill two 1/8" holes per latch in the windshield frame. Install each latch with two #8 x 5/8" Screws.

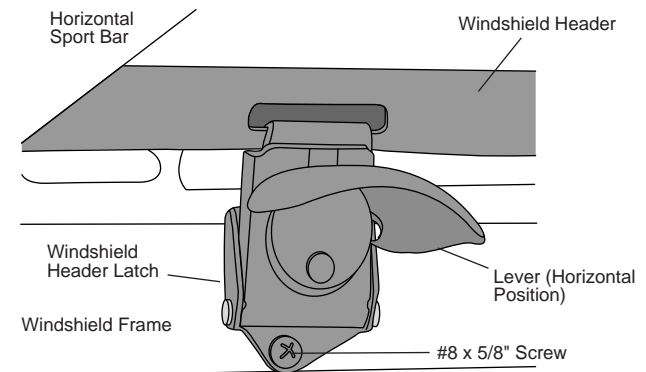

Sunrider® – Installation Instructions

10 Install Windshield Header Trim

Open the latches and raise the Windshield Header. Locate the rubber Windshield Header Trim in the parts kit. Slide the slotted edge of the trim over the front edge of the Windshield Header. Trim to fit.

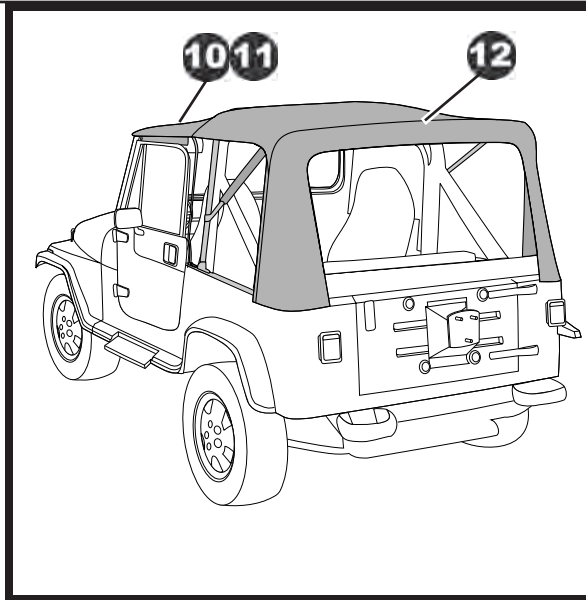
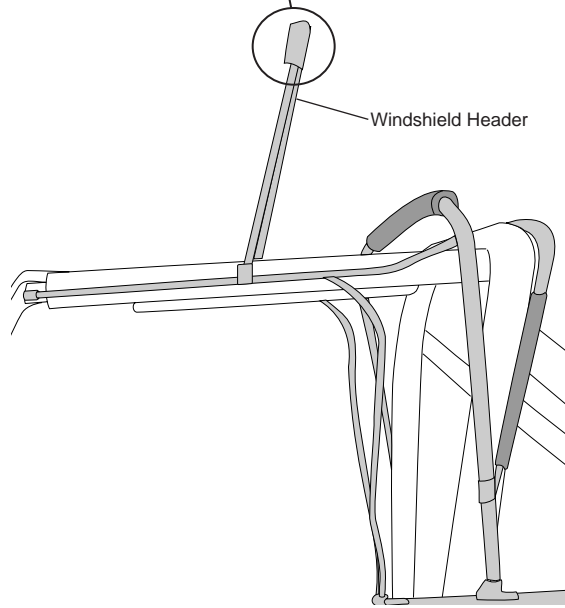
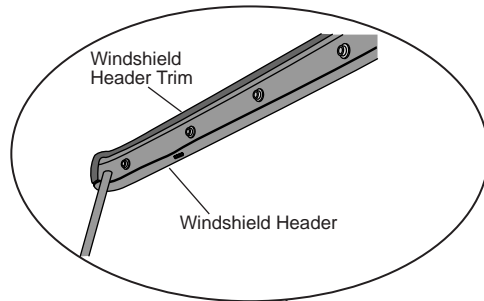

11 Install Top on Vehicle

Locate the top and orient it on the vehicle. Drape the top over the bows and wrap the front edge of the fabric around the front edge of the Windshield Header. Snap the fabric to the header.

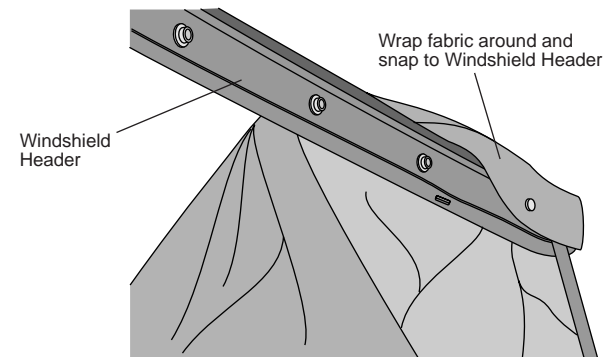

12 Snap Top to Rear Bow

Snap the flaps to the six studs on the rear bow.

NOTE If the snaps don't appear to line up, push the rear bow forward to relieve the pressure on the bow. This will allow the snaps to line up more easily.

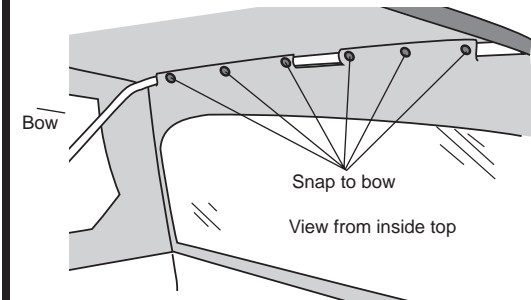

Sunrider® – Installation Instructions

13 Snap Top to Center Bow

Snap the six flaps inside center of the top to the studs on the center bow.

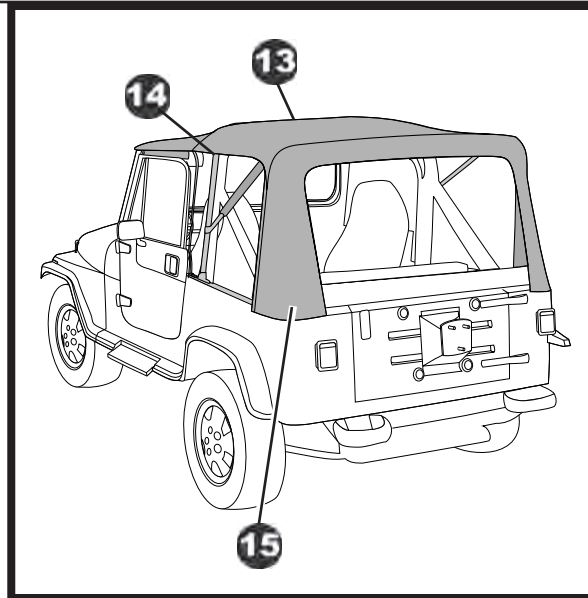
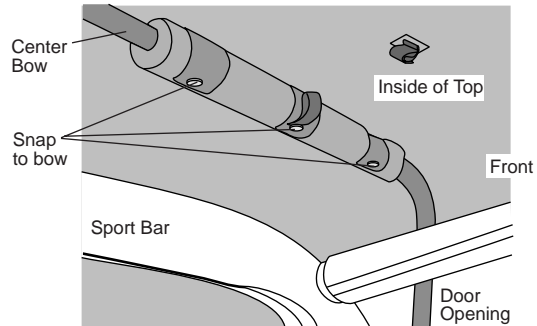

15 Secure Rear Corners

Insert the black plastic strips at rear corners of top into Corner Belt Rails. There is a plastic reinforcement sewn into the corner of the top, in addition to the plastic strip.

Make sure that the reinforcement is not caught under the Corner Belt Rail.

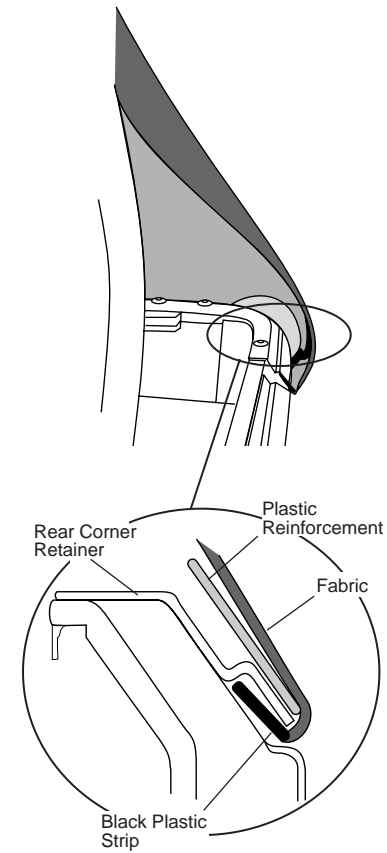

14

Snap the tab just behind the door opening on each side of the vehicle to the studs on the center bow.

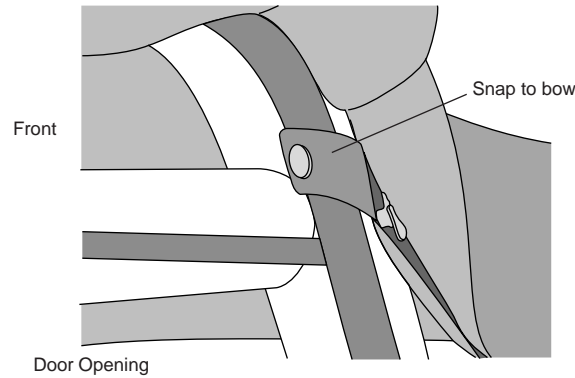

Sunrider® – Installation Instructions

16 Raise the Rear Bow

Slide the Rear Bow up on the Front Bow and insert the small bent tab into one of the four holes in the Front Bow.

NOTE If the top is extremely tight, slip the tab into the bottom hole. The top will loosen up after a few hours in the sun. Then the tab may be inserted into a higher hole position.

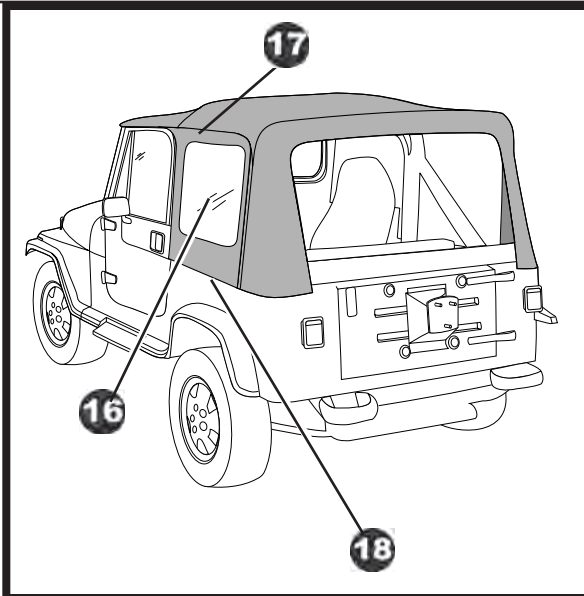
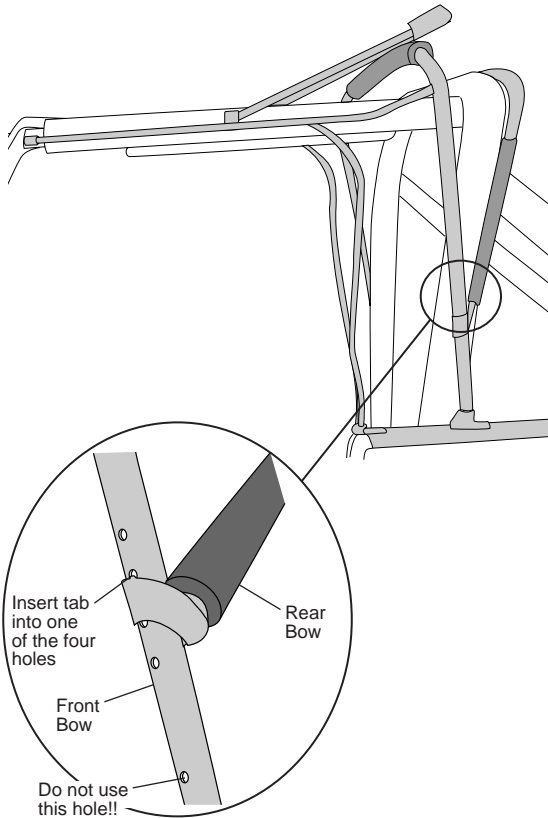

17 Install Side Curtain

Start zipper on Side Curtain 6 inches.

NOTE If necessary, release the Bow Coupler and slide the top around the Corner Belt Rail towards the window to make it easier to start the zippers on the Side Curtains.

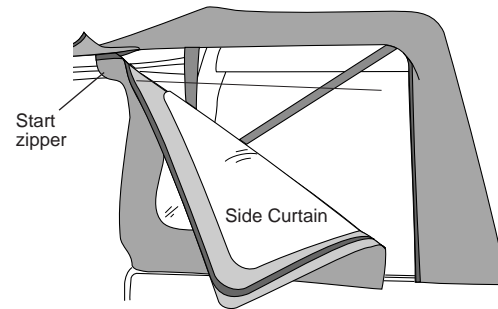

18 Secure Bottom of Side Curtain

Slip the plastic strip on the bottom of the Side Curtain into the side retainer. Close the top zipper on the Side Curtain.

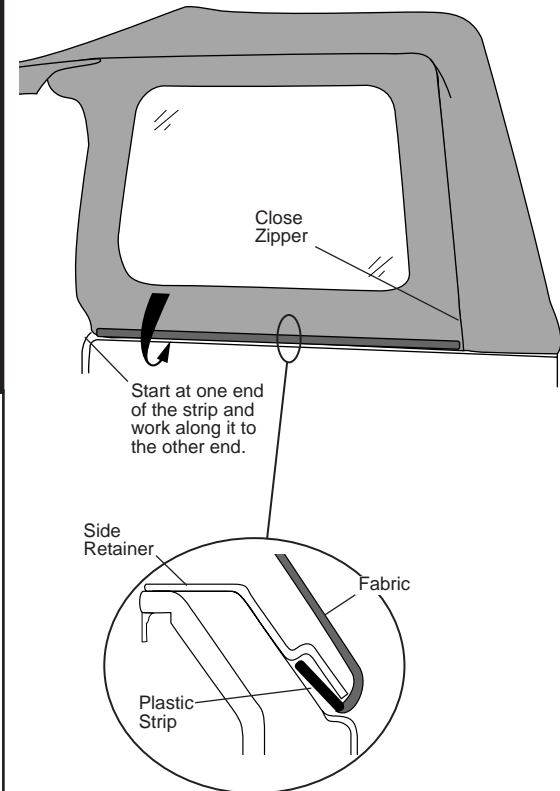

Sunrider® – Installation Instructions

19 Secure Front of Side Curtain

Wrap fabric flap on the front of the Side Curtain around the Vertical Rod (not the front bow) and fasten the hook and loop strips to each other.

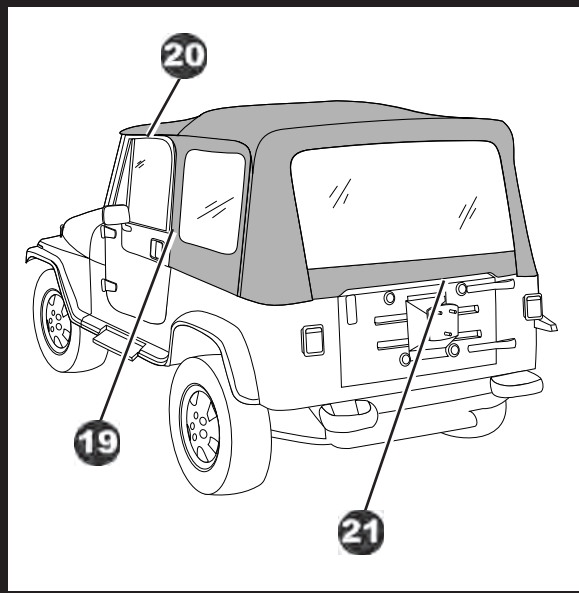
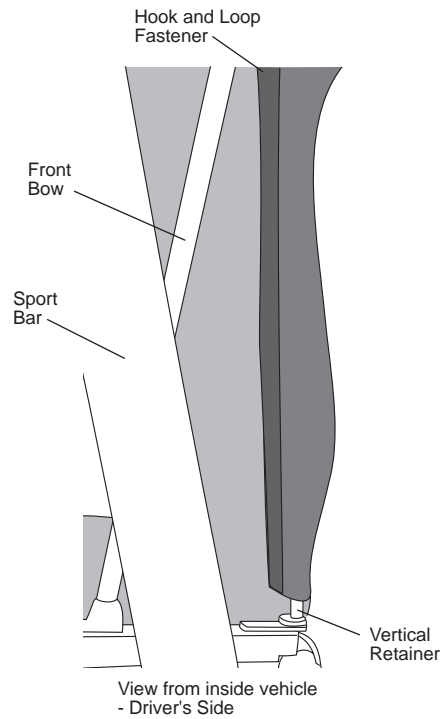

20 Secure Door Flaps

Wrap the flap, sewn to the top above each door, around the Horizontal Rod and fasten the hook and loop strips to each other.

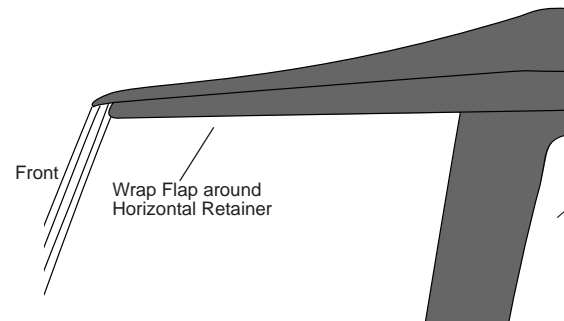

21 Install Rear Curtain Retainer

Open the tailgate. Orient the Rear Curtain Retainer with the rubber bulb facing down, in order to form a seal with the top of the tailgate. Slide the groove in the Rear Curtain Retainer onto the tube inside the bottom of the Rear Curtain. Roll the Rear Curtain Retainer into the top of the Corner Belt Rail. Slip the plastic on the bottom of the corners under the bottom of the Corner Belt Rail. Close the rear curtain zippers.

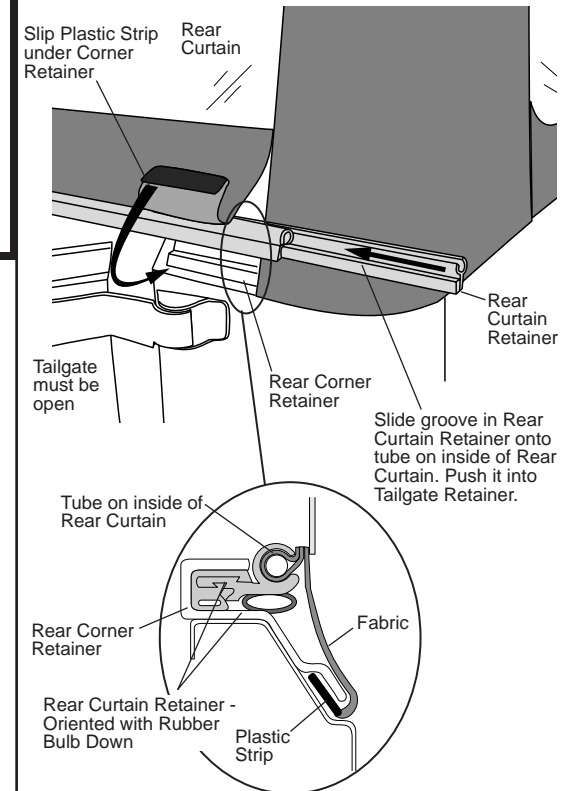

Sunrider® – Installation Instructions

NOTE Now that your soft top is fully installed there are some final Metal Door adjustments that may need to be made to give you the best weather seal possible.

! WARNING If any of these adjustments are made, make sure that each area has been retightened. Each area should be rechecked within a week to assure proper fit and function.

22 Adjusting Vertical Retainer

The Vertical Retainer mount may be loosened and moved either forward or to the rear of the vehicle to tighten the seal or to allow more clearance.

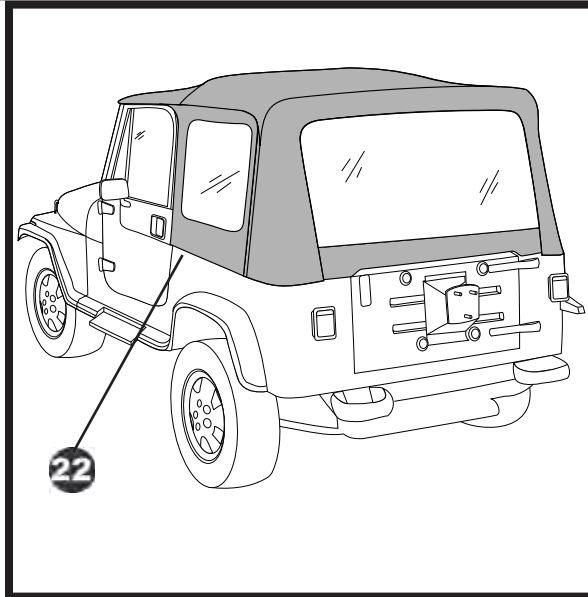
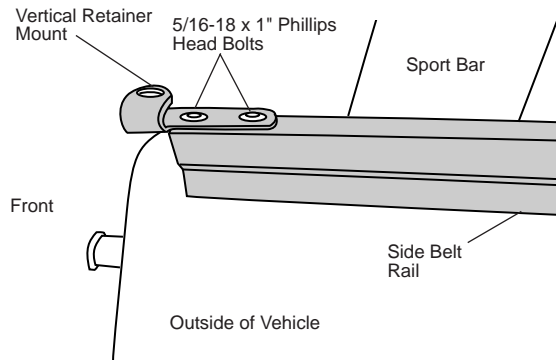

! WARNING When operating the vehicle without the Side Curtains, the Rear Curtain should be rolled up for proper ventilation.

23 Adjusting the Top

Side Curtains

To remove the Side Curtains. Unzip the rear and top zippers. Release the plastic strip from the retainer. Release the Hook and Loop Fasteners from around the Vertical Retainer.

Rear Curtain

To roll up the Rear Curtain, remove the Rear Curtain Retainer and start at the bottom, rolling it to the inside. Avoid wrinkles in the fabric and window. Secure it in place with the curtain straps inside of the top.

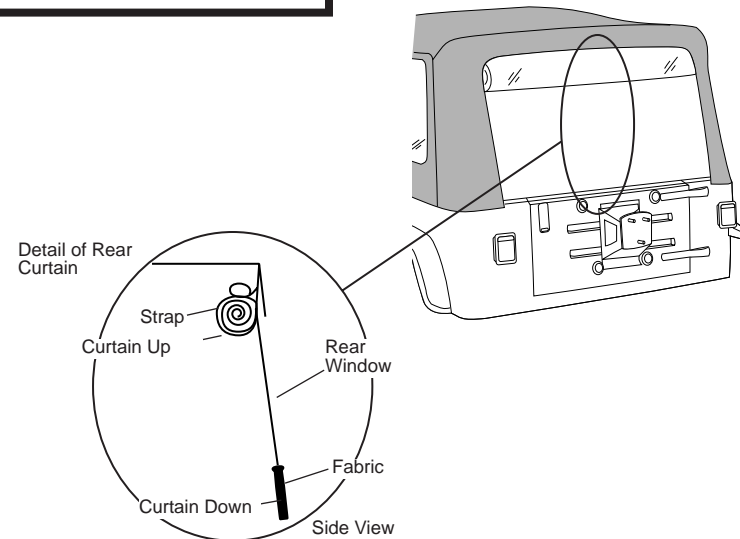

Sunrider® – Installation Instructions

24 Opening the Sun Roof

Release the Windshield Header Latches and fold the Windshield Retainer back so that it rests on the center bow and the sport bar. Roll the loose fabric in front of the bows so that the hook strips sewn to the inside of the fabric can be fastened to the loop attached to the center bow.

When not using the Sun Roof, roll the hook strips and secure with the loop tab.

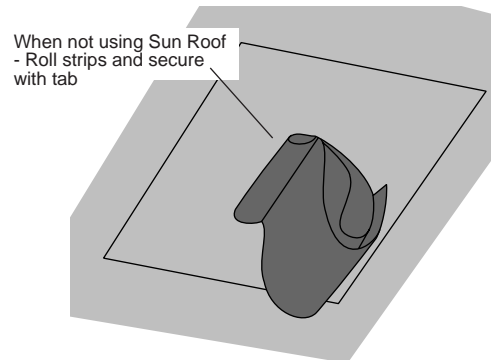
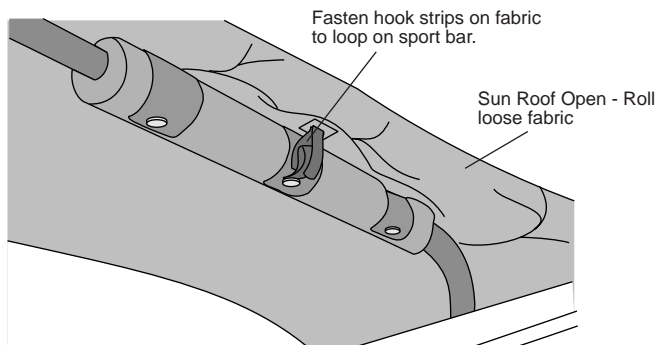

25 Removal of Soft Top for Open Air Driving

When operating the vehicle with the fabric top removed, it is very important that the supporting hardware system be disconnected from the windshield bracket and folded flat to the rear of the vehicle. The vertical and horizontal rods should be snapped into the plastic clips located on the inside of both bow mount brackets. Wrap the elastic straps around the bows and insert the plastic strip into the side belt rail. Never operate the vehicle with the fabric removed and the hardware in the fully erected position.

Sunrider® – Installation Instructions

Care and Maintenance of your Bestop Product

Your Bestop product is made of the finest materials available. To keep it looking new and for the maximum possible wear, it will need periodic cleaning and maintenance.

Washing: The fabric should be washed often using soap, warm water and a soft bristle brush. Rinse with clear water to remove all traces of soap or use Bestop-recommended Bestop Cleaner and Bestop Protectant. Bestop Cleaner and Bestop Protectant are specially formulated to provide a total cleaning and protection system. Bestop Cleaner will not harm vehicle finish, is biodegradable and environmentally friendly. Bestop Protectant protects against UV-fading, cracking and hardening.

Windows: Keep windows clean to avoid scratching. DO NOT use a brush on the windows! Wash with a water-soaked cloth or sponge and a mild dishwashing detergent or use Bestop-recommended Bestop Vinyl Window Cleaner, which safely cleans and protects vinyl windows while helping prevent UV damage. NEVER WIPE THE WINDOWS WHEN THEY ARE DRY. Be careful when cleaning snow or frost from the vinyl windows since they are easily scratched and may crack at low temperatures. DO NOT roll the sides or rear window in cold weather. The windows become stiff and will crack.

Zippers: Keeping the zipper cleaned and lubricated with a silicone lubricant will help prevent damage and keep the zippers in a smooth working condition. If a zipper opens behind the slider, the slider may have been spread apart. This problem can usually be repaired by using an ordinary pair of pliers to bring the sides back into parallel. Return slider to the end of the zipper in the normal Open position. Squeeze lightly at first and test the zipper. If the zipper continues to remain open squeeze more firmly with the pliers and try the zipper again. Repeat this procedure until the zipper operates correctly.

Water: Seeping through at the seams may be stopped by applying 3-M Scotchgard® on the inside of the seams. Rips in the fabric may be repaired with Bondex® iron on patches. Iron the patches to the Inside of the top, carefully following the Bondex® instructions.

Snaps: Keep snaps cleaned and lubricated with silicone to help prevent snaps from sticking to the studs. If a snap does become stuck to a stud, use a screwdriver and GENTLY pry apart to prevent permanent damage to the snap or the top fabric.

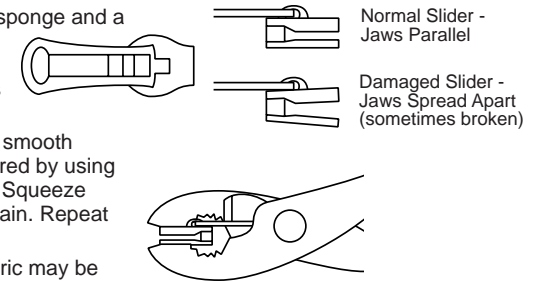

LIMITED WARRANTY

We warrant our product to be free from defects in material and workmanship, for the terms specified below, provided there has been normal use and proper maintenance. This warranty applies to the original purchaser only. All remedies under this warranty are limited to the repair or replacement of any item or items found by the factory to be defective within the time period specified. If you have a warranty claim, first you must call our factory at the number below for instructions. You must retain proof of purchase and submit a copy with any items returned for warranty work. Upon completion of warranty work, if any, we will return the repaired or replaced item or items to you freight prepaid. Damage to our products caused by accidents, fire, vandalism, negligence, misinstallation, misuse, Acts of God, or by defective parts not manufactured by us, is not covered under this warranty.

THE WARRANTY TIME PERIOD IS AS FOLLOWS FOR REPLACE-A-TOP™, SAILCLOTH REPLACE-A-TOP™, SUPERTOP®, SUPERTOP® REPLACEMENT SKINS, SUNRIDER®, AND TIGERTOP®: TWO YEARS FROM DATE OF PURCHASE.

THE WARRANTY TIME PERIOD IS AS FOLLOWS FOR ALL OTHER "SOFT GOODS" MANUFACTURED BY OUR COMPANY (USING PRIMARILY VINYL, PLASTICS, AND/OR FOAM): ONE YEAR FROM DATE OF PURCHASE.

THE WARRANTY TIME PERIOD IS AS FOLLOWS FOR ALL OTHER "HARD GOODS" MANUFACTURED BY OUR COMPANY (USING PRIMARILY METALS, PLASTICS, AND/OR FIBERGLASS): ONE YEAR FROM DATE OF PURCHASE.

ANY IMPLIED WARRANTIES OF MERCHANTABILITY AND/OR FITNESS FOR A PARTICULAR PURPOSE CREATED HEREBY ARE LIMITED IN DURATION TO THE SAME DURATION AND SCOPE AS THE EXPRESS WRITTEN WARRANTY. OUR COMPANY SHALL NOT BE LIABLE FOR ANY INCIDENTAL OR CONSEQUENTIAL DAMAGE.

Some states do not allow limitations on how long an implied warranty lasts, or the exclusion or limitation of incidental or consequential damages, so the above limitations or exclusions may not apply to you. This warranty gives you specific legal rights, and you may also have other rights which vary from state to state.



For further information or request for warranty work, please contact:

Bestop Inc., Customer Service
Toll-Free: (800)845-3567
Main: (303)465-1755
E-mail: csbestop@Bestop.com
Website: www.Bestop.com