



BESTOP

Halftop Installation Instructions

**For: 1997 - 2002 Wrangler
with Factory Hard Top**

Part Number: 53819

US Patent D474,145

DO NOT INSTALL THIS PRODUCT ON ANY VEHICLE OTHER THAN THOSE LISTED ABOVE.

In order to prevent sagging, pooling and leakage, remove snow and water from the rear portion of the Halftop, when applicable.

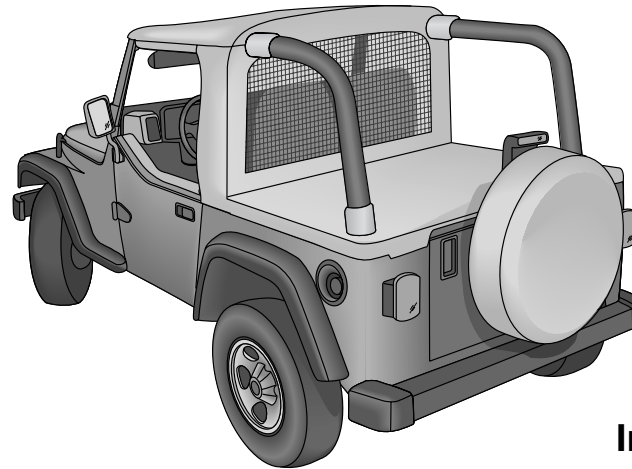

WARNING

This product is designed to enhance the appearance of the vehicle and to shield the occupants from ordinary weather conditions. Do not rely in any way on the components of this product to contain occupants within the vehicle, or to protect against injury or death in the event of an accident. This product will not protect the occupants from falling objects. Never operate vehicle in excess of manufacturer's specifications.

WEAR SEAT BELTS AT ALL TIMES

Read and follow, precisely, all installation instructions provided when installing this product. Failure to do so may result in a poor fit and could place occupants of the vehicle in a potentially dangerous situation. Failure to properly install or reinstall this product may cause the top or a component part to come off the vehicle, potentially causing an accident and possible injury to the occupants of the vehicle. After installing or reinstalling the top, check to make sure it has been properly installed.

Installation Tips

Before you begin installing this top assembly, read all instructions thoroughly. After completing the installation, keep these instructions for further reference. Below are a few tips to make this installation easier.

For a smooth fit:

For ease in installation, the top should be installed at temperatures above 72° F. Below this temperature, the top may contract an inch or more, making it difficult to fit to the vehicle.

It is normal for a top to contract and wrinkle when stored in the shipping carton. Within a few days after the installation, the top will relax and the wrinkles will disappear.

Parts List and Hardware Identification

Halftop Fabric, Qty - 1

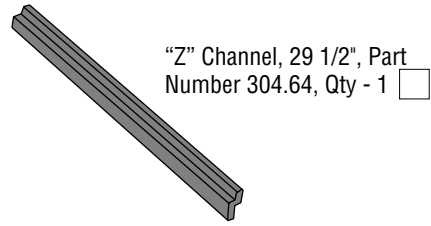

"Z" Channel, 29 1/2", Part Number 304.64, Qty - 1

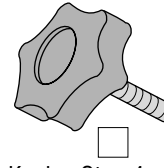

Knobs, Qty - 4, Part Number 316.85

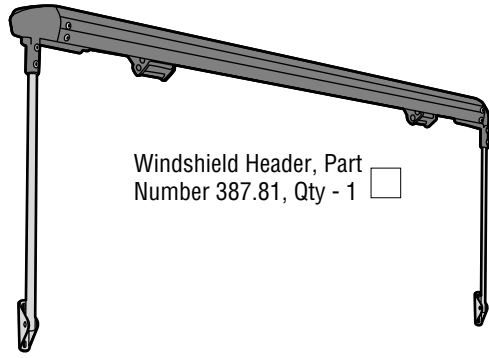

Windshield Header, Part Number 387.81, Qty - 1

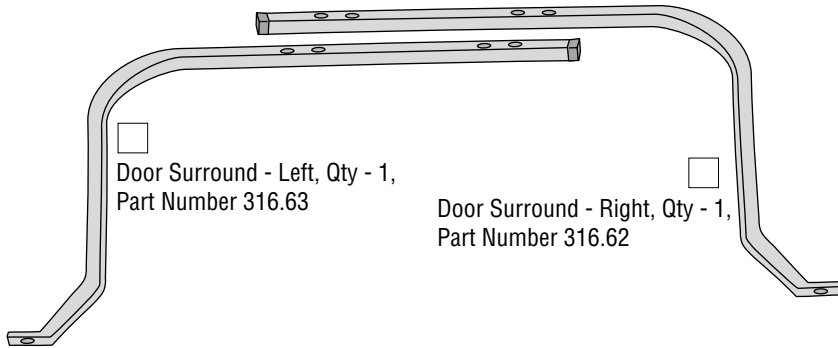

Door Surround - Left, Qty - 1, Part Number 316.63

Door Surround - Right, Qty - 1, Part Number 316.62

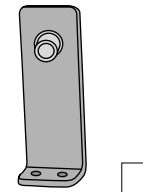

Rear Door Surround Brackets, Qty - 2, Part Number 386.70

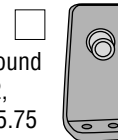

Front Door Surround Brackets, Qty - 2, Part Number 315.75

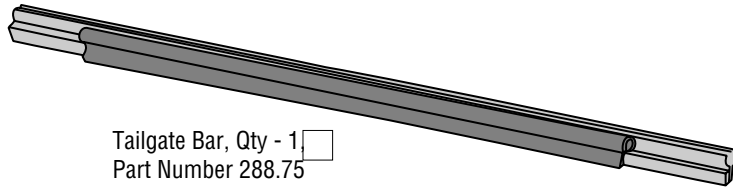

Tailgate Bar, Qty - 1, Part Number 288.75

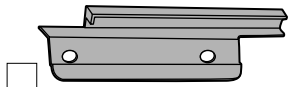

Tailgate Retainer Mount, Left, Qty - 1, Part Number 311.85

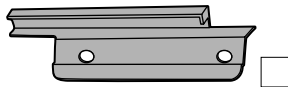

Tailgate Retainer Mount, Right, Qty - 1, Part Number 311.86

Tools Needed

Drill Motor
1/8" Drill Bit
Center Punch
Safety Glasses
Phillips Screwdriver
Pencil
Silicone Sealer

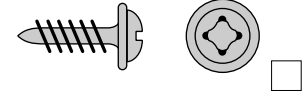

#8 x 1/2" Pan Head Washer Screw, Part Number 200.48, Qty - 8

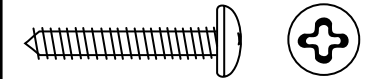

#8 x 1" Pan Head Screw, Part Number 295.95, Qty - 5

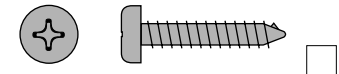

#10 Phillips Head Self Tapping Screw, Qty - 8, Part Number 319.99

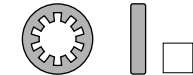

#10 Star Washer, Qty - 8, Part Number 317.58

Loctite, Qty - 1, Part Number 309.83



Caution

Safety glasses should be worn at all times while installing this product. Disconnect the battery before installing Halftop.

Hardware Installation



WARNING

Check for wiring and fuel lines before drilling holes in riser.

Do not remove the "Z" Channel from your vehicle once it has been installed. If this is necessary, make sure the screw holes have been covered with a sealer.

Step One

"Z" CHANNEL INSTALLATION

Fold the front seats forward and locate the "Z" Channel in the parts kit. Orient the channel so that, when installed, the opening will be down. Place the channel on the vertical face of the riser between the front and rear floors, centered in the flat area in the middle of the vehicle. The top edge of the channel should be flush with the top of the riser. Use the holes in the channel as guides to mark, center punch and drill five 1/8" holes. Use silicone sealer on the holes before installing the channel. Install the channel using the five #8 x 1" Pan Head Screws from the parts kit.

Note: It is easier to drill holes by either slitting the carpet with a 1/2" "X" shape to access the sheet metal, or center punch through the carpet, remove the carpet and drill the necessary holes - then add smaller slits in the carpet to access the holes for attachment.

If the vehicle is equipped with a factory console, it will be necessary to leave the center screw out of the channel.

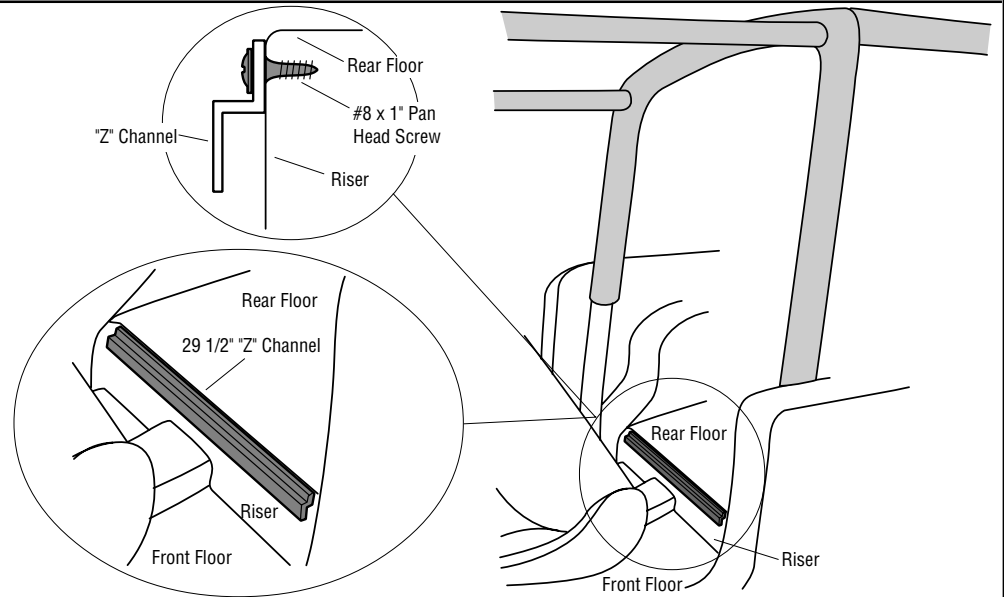

Step Two

ASSEMBLE DOOR SURROUNDS AND FRONT AND REAR DOOR SURROUND BRACKETS

Locate the Left and Right Door Surrounds, the Front Door Surround Brackets and the Rear Door Surround Brackets in the parts kit. The longer brackets are the Rear Door Surround Brackets. The hook strip on the Door Surrounds should be toward the outside of the vehicle.

Place the holes in the Front and Rear Door Surround Brackets over the two pairs of holes on each Door Surround. Orient the brackets with the long tab toward the inside and with the threaded rivet up. Install the brackets using two #10 Phillips Head Self Tapping Screws and two #10 Star Washers for each bracket.

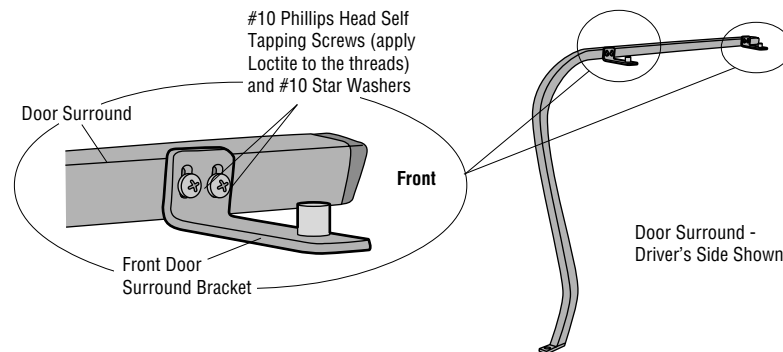

Step Three

INSTALL DOOR SURROUND ASSEMBLIES

Orient the Left and Right Door Surround Assemblies on the vehicle with the brackets toward the inside and the hook strip toward the outside. Insert the nipples in the brackets into the holes in the bottom of the Horizontal Support Bar. Thread a Knob from the parts kit through the top of the Horizontal Support Bar and into each of the Door Surround Brackets. Close the door to check the seal and adjust the Front Door Surround Bracket if necessary for a good seal.

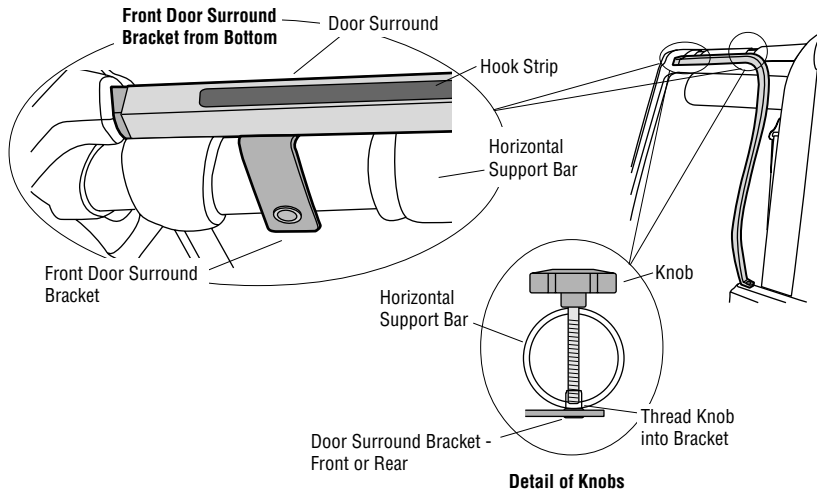

Step Four

INSTALL DOOR SURROUND ASSEMBLIES

Secure the bottom of the Door Surround to the vehicle using a 5/16-18 x 1 Phillips Head Bolt, a 5/16" Washer and a 5/16-18 Tapping Plate. Place the Tapping Plate under the ledge, aligning the hole in the plate with the hole in the vehicle and install the screw and washer from the top. Test the door seal again and adjust the bottom of the Door Surround if necessary for a good seal.

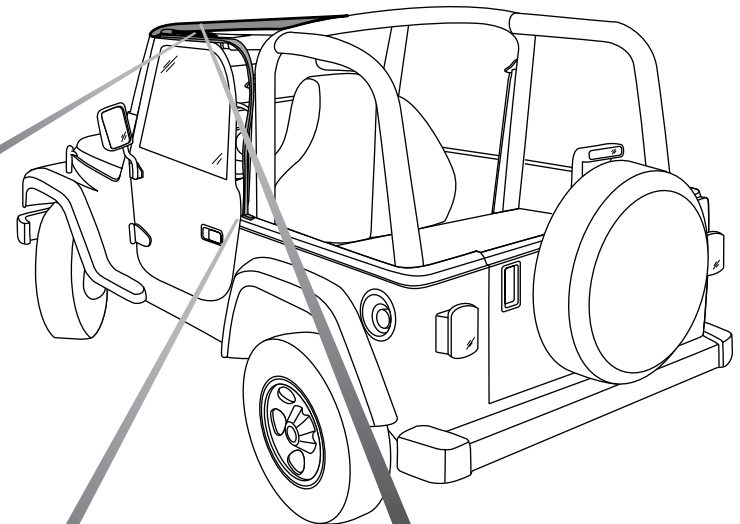
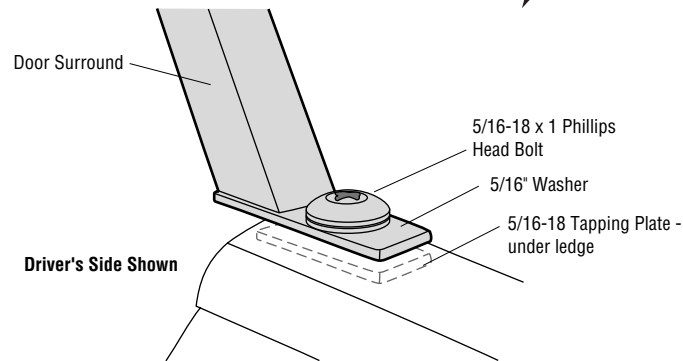

Step Five

WINDSHIELD HEADER INSTALLATION

Orient the Windshield Header on the vehicle and lay it on top of the windshield frame. Catch the hook on the header in the slot in the windshield frame and close the lever over it. This will hold the header securely in position.

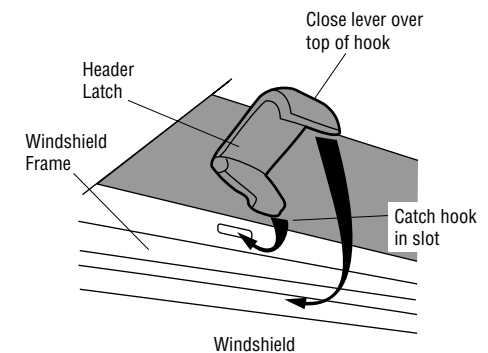

Step Six

WINDSHIELD HEADER INSTALLATION

Use the rear hole in the Windshield Header mounting bracket as a guide to drill a 1/8" hole in the Door Surround. Install a #8 x 1/2" Pan Head Washer Screw to secure the bracket to the vehicle. Repeat this on the other side of the vehicle.

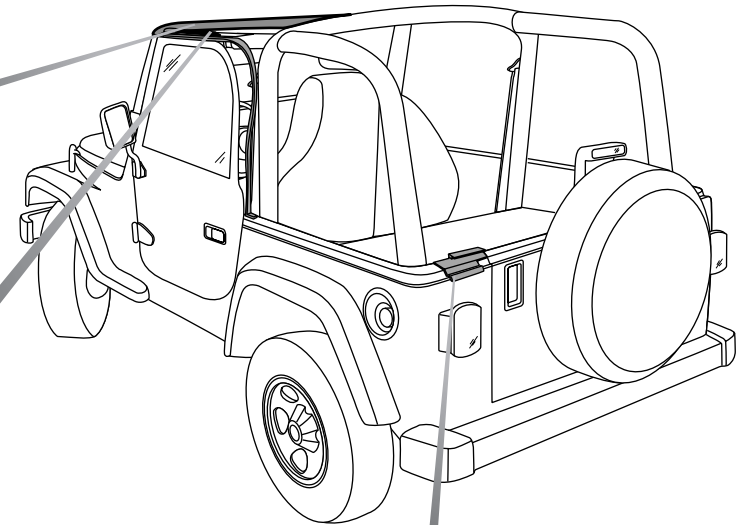
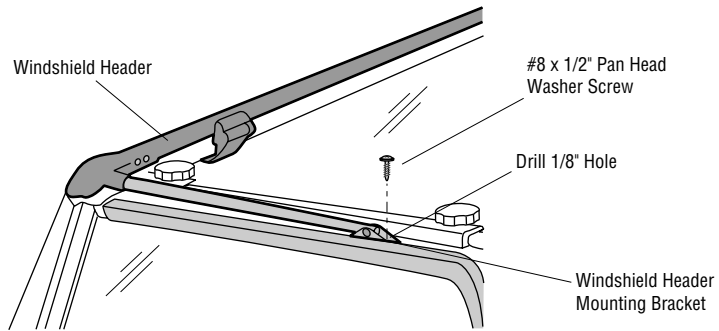

Step Seven

WINDSHIELD HEADER INSTALLATION

Release the header latches and fold the Windshield Header back to reveal the front holes in the mounting bracket. Use the front hole in the bracket as a guide to drill a 1/8" hole. Install a #8 x 1/2" Pan Head Washer Screw. Repeat this on the other side of the vehicle.

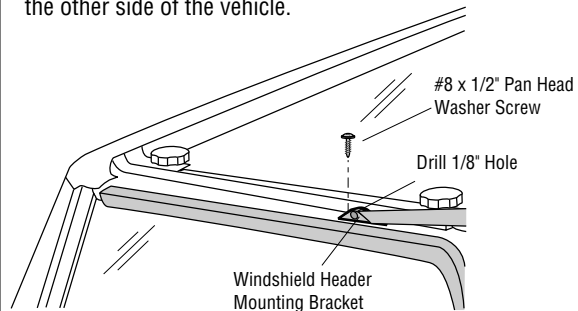

Step Eight

INSTALL TAILGATE RETAINER MOUNTS

Locate the left and right Tailgate Retainer Mounts. Place the mounts flush with the edge of the tailgate opening. Install the Tailgate Retainer Mounts with two #8 x 1/2" Pan Head Washer Screws for each mount.

If your vehicle does not have holes at this location, align the Tailgate Retainer Mounts flush with the edge of the tailgate opening. Then mark the locations of the holes in the mounts, center punch and drill a 1/8" hole at the marked locations. Install the mounts with two #8 x 1/2" Pan Head Washer Screws for each mount.

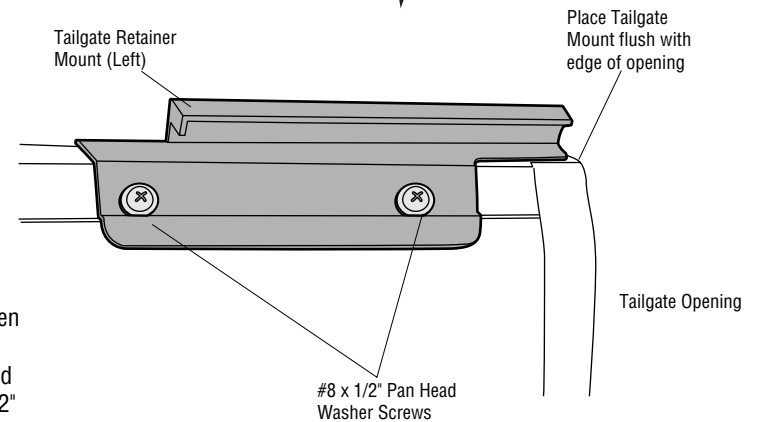

Halftop Fabric Installation

Step Nine

ATTACH HALFTOP TO WINDSHIELD HEADER

Open the Windshield Header and stand inside the vehicle to access the front of the assembly. Wrap the front edge of the Halftop Fabric around the front edge of the Windshield Header. Make sure that the fabric is centered on the header. Press the plastic retainer along the front of the top into the channel on the header until it **snaps** into the channel.

Wrap Fabric around Windshield Header and snap plastic retainer into channel in header

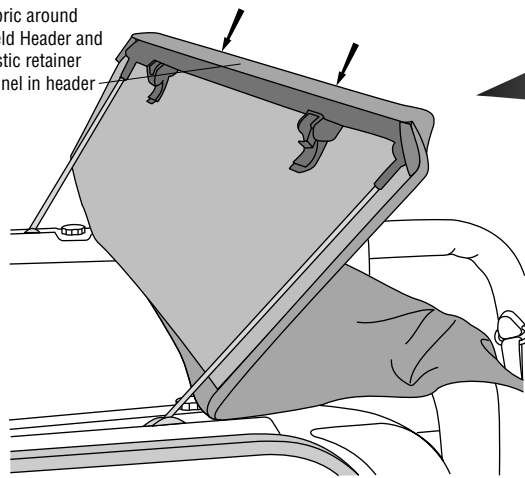

Note: Make sure the plastic retainer is snapped **firmly** into the Header channel. The Sun Roof feature will not work properly if the retainer is not securely installed.

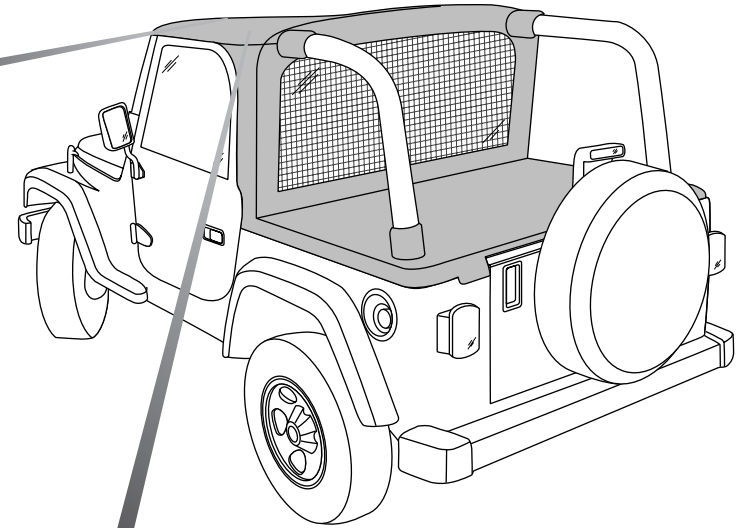

Step Ten

WEB STRAP THROUGH FOOTMAN LOOP

Locate the web strap sewn inside the top. Make sure that it is above the Sport Bar and pull it to the windshield. Thread the end of the strap through the Footman Loop on the windshield frame and then loosely back through the buckle on the strap. **DO NOT** tighten the strap at this time.

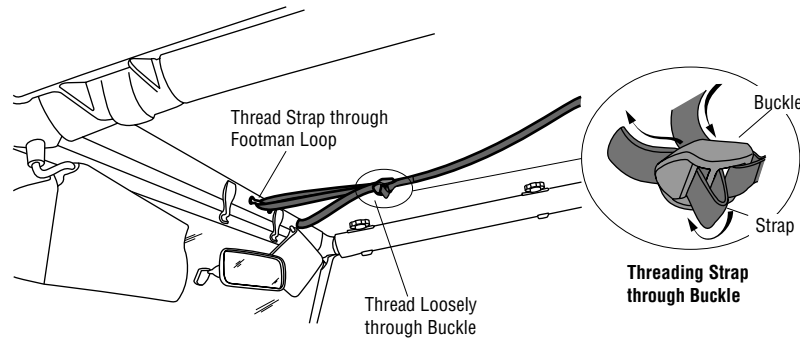

Step Eleven

SECURE MESH DIVIDER

Rotate the Windshield Header forward and lay it along the top of the windshield frame. Locate plastic strip sewn to the bottom of the mesh divider inside the vehicle. Roll the plastic into the "Z" Channel.

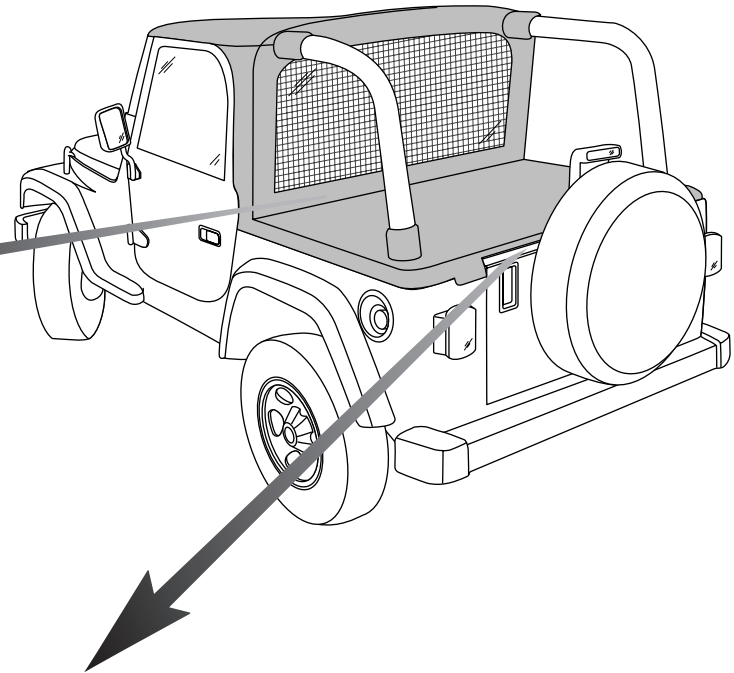
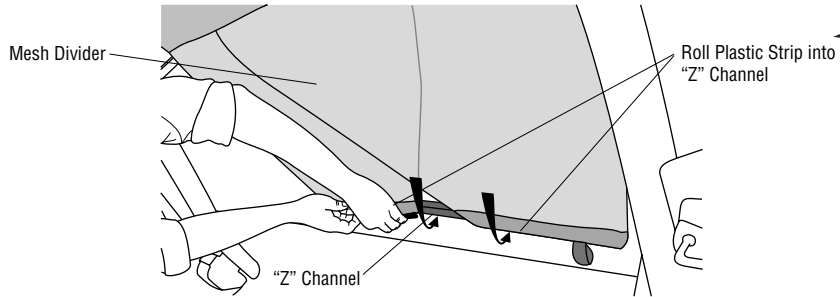

Step Twelve

INSTALL THE TAILGATE BAR

Open the tailgate. Orient the Tailgate Bar with the rubber bulb facing down, in order to form a seal with the top of the tailgate. Slide the groove in the Tailgate Bar onto the tube inside the rear of the Halftop. Roll the Tailgate Bar into the top of the Tailgate Retainer Mounts. Slip the plastic on the bottom of the Halftop under the bottom part of the Tailgate Retainer Mounts.

Slip Plastic Strip under Tailgate Retainer Mount

Tailgate must be open

Tailgate Retainer Mount

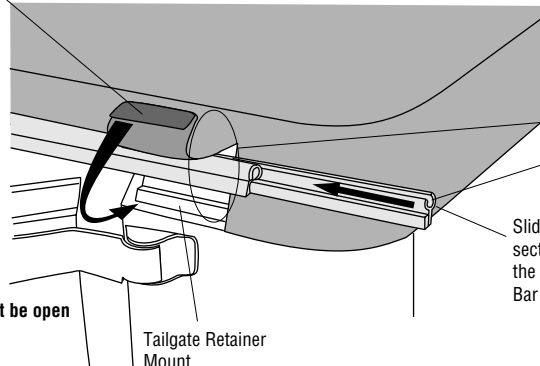

Tailgate Bar

Slide the tube on the rear section of the Halftop into the groove in the Tailgate Bar

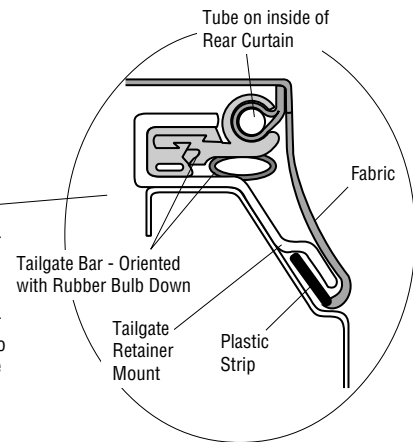

Note: This product is designed for a "Custom Fit". Be patient during the installation, it fits tight!

Step Thirteen

INSTALL SIDE RETAINERS

Locate the plastic strip sewn to the Halftop along each side of the vehicle. Start at one end on each side and roll the plastic strip into the Side Retainers.

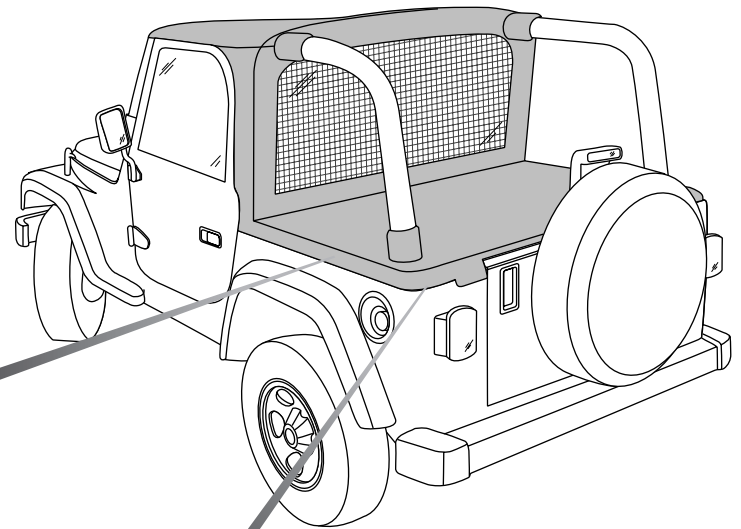
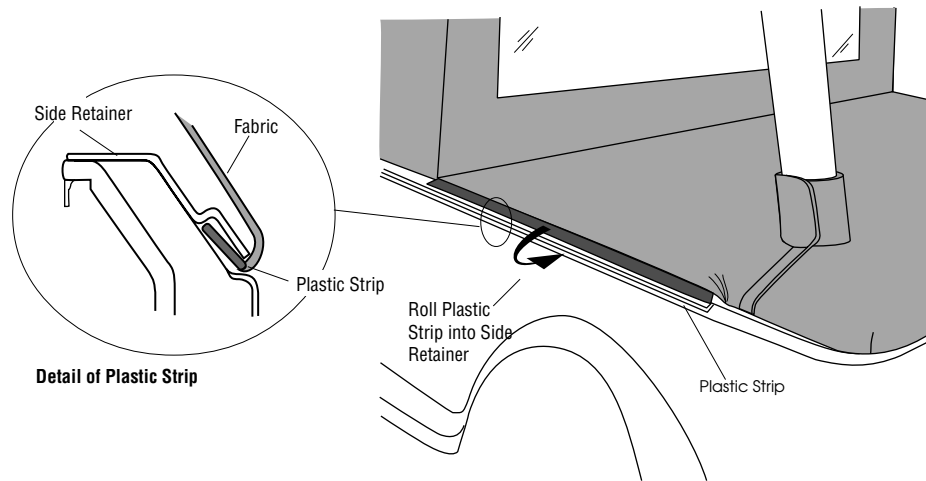

Step Fourteen

INSTALL REAR CORNERS

Roll the plastic strips, sewn into the rear corners of the Halftop into the Corner Retainers. Slide the corner plastic strip toward the front of the vehicle and make sure that the plastic strip fits up into the retainer so that the collar fits smoothly.

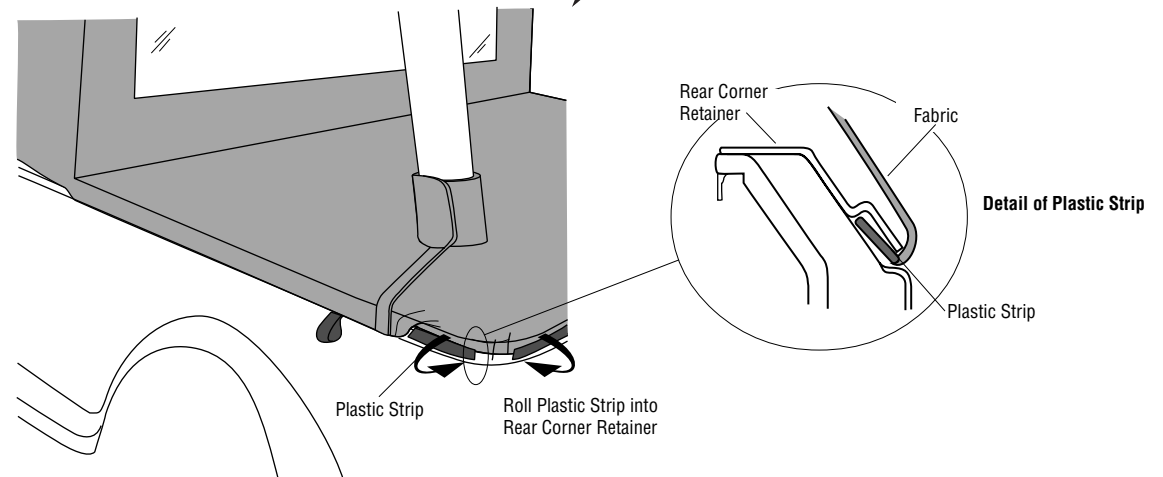

Note: The Plastic Protector sewn into the fabric must be properly located to minimize abrasion between the Halftop Rear Section and the Tailgate Retainer Mounts.

Step Fifteen

SECURE SPORT BAR COLLARS

Tuck the seat belt assemblies into the rear sport bar collars and close the rear sport bar collars by pulling firmly on the fabric and fastening the Hook and Loop Strips to each other. Then secure the Hook and Loop Strips on the upper sport bar collars.

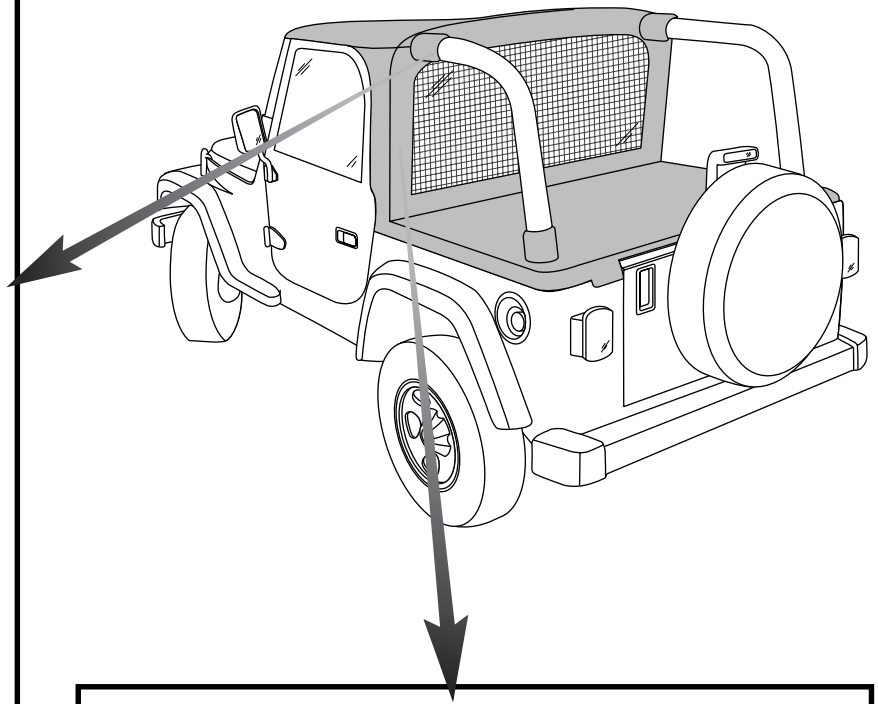
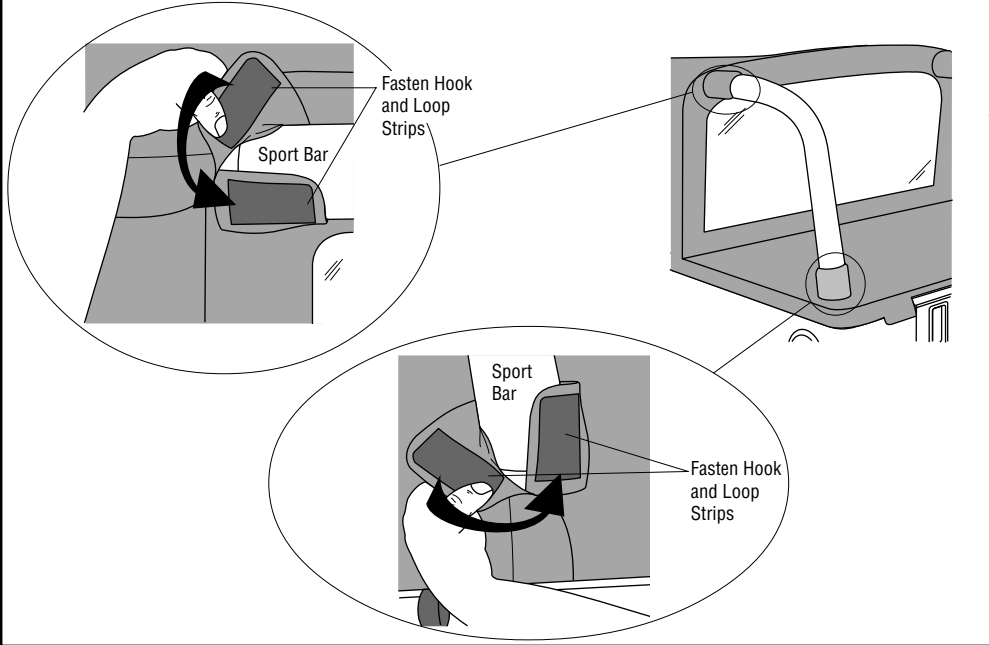

Step Sixteen

SECURE DOOR OPENING

Pull the fabric around the door surround at the rear of the door opening and fasten the hook and loop strip. Then roll the plastic at the bottom of the panel behind the door into the retainer. Make sure that the fabric is smooth where the retainers meet.

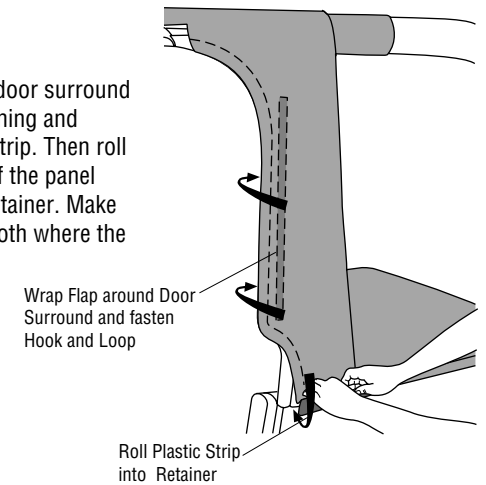

Step Seventeen

SECURE WINDSHIELD HEADER

Close the front deck completely and secure the latches in the Windshield Retainer to the windshield.

Tighten the web strap.

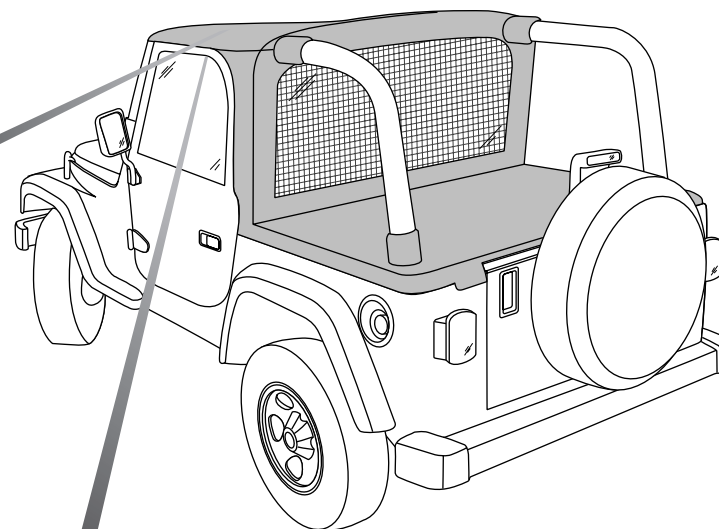
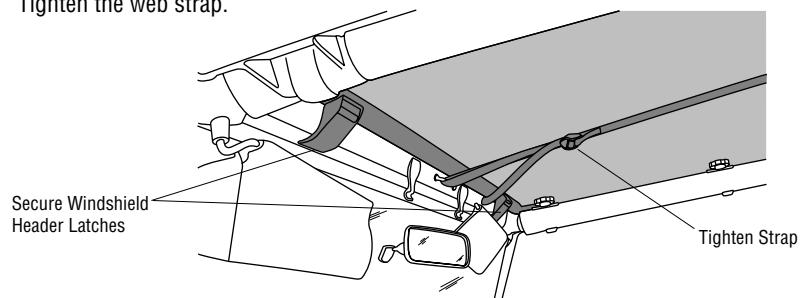

Step Eighteen

SECURE SIDES OF FRONT DECK

Fasten the loop strip sewn to the Halftop to the hook strip on the Door Surround above the door opening.

Fasten Loop Strip on fabric to Hook Strip on Door Surround

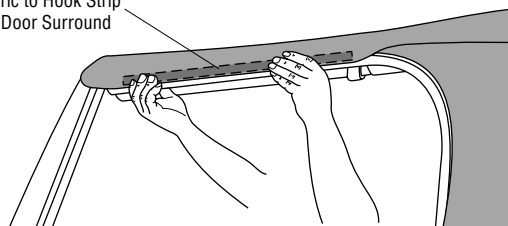

Using the Halftop Features



WARNING

DO NOT Open the Sun Roof while driving.

To Open Sun Roof

Open the Windshield Header latches to release the header from the windshield. Release the Hook and Loop Strip on the Door Surround. Rotate the front of the header toward the rear of the vehicle.

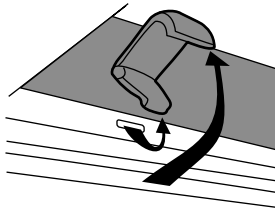

Release Windshield Header Latches

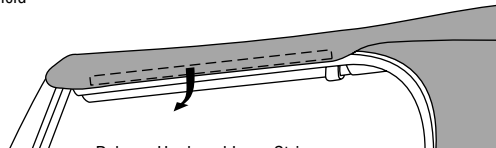

Release Hook and Loop Strip

Fold Front of Deck Back

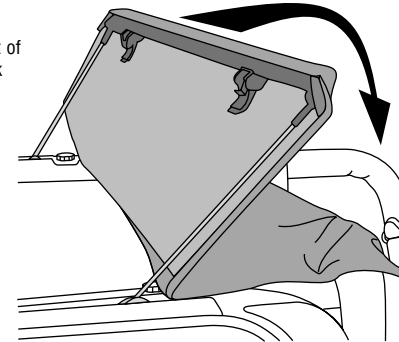

Opening the Rear Window

OPENING WINDOW

The window may be opened partially or completely by unzipping it. If completely unzipped it may be folded down and left in place.

REMOVING WINDOW

To remove the window completely, unzip it and release the snaps at the bottom corners. Then release the Hook and Loop strip along the bottom of the window opening.

REINSTALLING WINDOW

In order to reinstall the window all the zipper slides must be together at the end of the zipper or they will not catch properly. Close the zipper, secure the Hook and Loop strip along the bottom and attach the snaps on the corners.

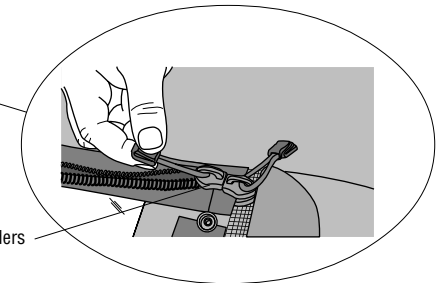
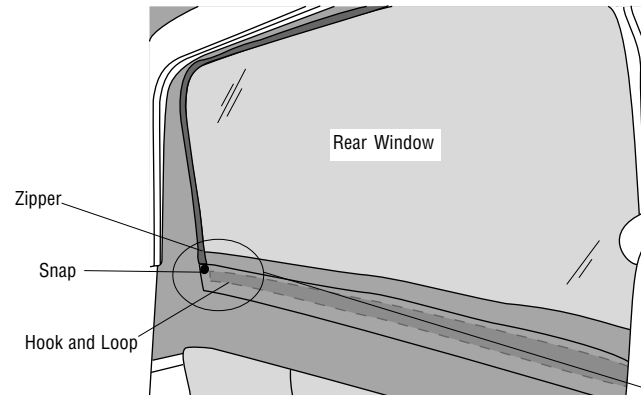

Care and Maintenance of your Bestop Product

Your Bestop product is made of the finest materials available. To keep it looking new and for the maximum possible wear, it will need periodic cleaning and maintenance.

Washing: The fabric should be washed often using soap, warm water and a soft bristle brush. Rinse with clear water to remove all traces of soap or use Bestop-recommended Bestop Cleaner and Bestop Protectant. Bestop Cleaner and Bestop Protectant are specially formulated to provide a total cleaning and protection system. Bestop Cleaner will not harm vehicle finish, is biodegradable and environmentally friendly. Bestop Protectant protects against UV-fading, cracking and hardening.

Windows: Keep windows clean to avoid scratching. DO NOT use a brush on the windows! Wash with a water-soaked cloth or sponge and a mild dishwashing detergent or use Bestop-recommended Bestop Vinyl Window Cleaner, which safely cleans and protects vinyl windows while helping prevent UV damage.

NEVER WIPE THE WINDOWS WHEN THEY ARE DRY. Be careful when cleaning snow or frost from the vinyl windows since they are easily scratched and may crack at low temperatures. DO NOT roll the sides or rear window in cold weather. The windows become stiff and will crack.

Zippers: Keeping the zipper cleaned and lubricated with a silicone lubricant will help prevent damage and keep the zippers in a smooth working condition. If a zipper opens behind the slider, the slider may have been spread apart. This problem can usually be repaired by using an ordinary pair of pliers to bring the sides back into parallel. Return slider to the end of the zipper in the normal Open position. Squeeze lightly at first and test the zipper. If the zipper continues to remain open squeeze more firmly with the pliers and try the zipper again. Repeat this procedure until the zipper operates correctly.

Water: Seeping through at the seams may be stopped by applying 3-M Scotchgard® on the inside of the seams. Rips in the fabric may be repaired with Bondex® iron on patches. Iron the patches to the Inside of the top, carefully following the Bondex® instructions.

Snaps: Keep snaps cleaned and lubricated with silicone to help prevent snaps from sticking to the studs. If a snap does become stuck to a stud, use a screwdriver and GENTLY pry apart to prevent permanent damage to the snap or the top fabric.

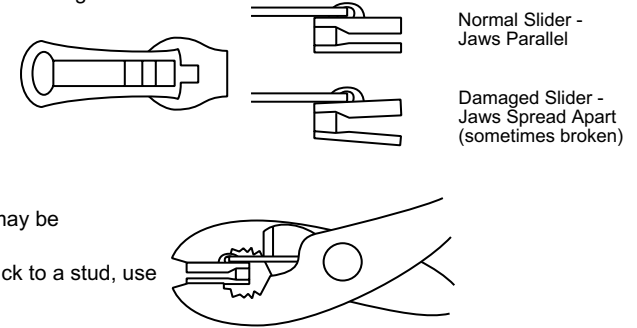

LIMITED WARRANTY

We warrant our product to be free from defects in material and workmanship, for the terms specified below, provided there has been normal use and proper maintenance. This warranty applies to the original purchaser only. All remedies under this warranty are limited to the repair or replacement of any item or items found by the factory to be defective within the time period specified. If you have a warranty claim, first you must call our factory at the number below for instructions. You must retain proof of purchase and submit a copy with any items returned for warranty work. Upon completion of warranty work, if any, we will return the repaired or replaced item or items to you freight prepaid. Damage to our products caused by accidents, fire, vandalism, negligence, misinstallation, misuse, Acts of God, or by defective parts not manufactured by us, is not covered under this warranty.

THE WARRANTY TIME PERIOD IS AS FOLLOWS FOR REPLACE-A-TOP™, SAILCLOTH REPLACE-A-TOP™, SUPERTOP®, SUPERTOP® REPLACEMENT SKINS, SUNRIDER®, AND TIGERTOP®: TWO YEARS FROM DATE OF PURCHASE.

THE WARRANTY TIME PERIOD IS AS FOLLOWS FOR ALL OTHER "SOFT GOODS" MANUFACTURED BY OUR COMPANY (USING PRIMARILY VINYL, PLASTICS, AND/OR FOAM): ONE YEAR FROM DATE OF PURCHASE.

THE WARRANTY TIME PERIOD IS AS FOLLOWS FOR ALL OTHER "HARD GOODS" MANUFACTURED BY OUR COMPANY (USING PRIMARILY METALS, PLASTICS, AND/OR FIBERGLASS): ONE YEAR FROM DATE OF PURCHASE.

ANY IMPLIED WARRANTIES OF MERCHANTABILITY AND/OR FITNESS FOR A PARTICULAR PURPOSE CREATED HEREBY ARE LIMITED IN DURATION TO THE SAME DURATION AND SCOPE AS THE EXPRESS WRITTEN WARRANTY. OUR COMPANY SHALL NOT BE LIABLE FOR ANY INCIDENTAL OR CONSEQUENTIAL DAMAGE.

Some states do not allow limitations on how long an implied warranty lasts, or the exclusion or limitation of incidental or consequential damages, so the above limitations or exclusions may not apply to you. This warranty gives you specific legal rights, and you may also have other rights which vary from state to state.

For further information or request for warranty work, please contact:

Bestop Inc., Customer Service

Toll-Free: (800)845-3567

Main: (303)465-1755

E-mail: csbestop@Bestop.com

Website: www.Bestop.com

