





# Installation Instructions







## Supertop® with Tinted Side and Rear Windows and 2-Piece Soft Doors

### Vehicle Application:

- Jeep Wrangler TJ  
1997 – 2006  
Part Number: 54713

[www.Bestop.com](http://www.Bestop.com) - We're here to help! Visit our web site and click on "[Ask a Question](#)". Click here for more [Jeep Accessories by Bestop](#).

INSTALLATION TIME	SKILL LEVEL
 <p><b>3 Hours</b></p>	 <p><b>3 - Moderately Difficult</b></p>

TOOLS			
 <p>Phillips Screwdriver #2</p>	 <p>Wrench 1/2" and 9/16"</p>	 <p>Power Drill 1/8" Bit</p>	 <p>Center Punch</p>
 <p>Hammer</p>	 <p>Torx Wrench #40</p>	 <p>Safety Glasses</p>	



 **CAUTION** Safety glasses should be worn at all times while installing this product.

### Installation Tips

Before you begin installing this assembly, read all instructions thoroughly.

#### For a smooth fit:

For ease in installation, the product should be installed at temperatures above 72° F. Below this temperature, the fabric may contract an inch or more, making it difficult to fit to the vehicle. It is normal for fabric to contract and wrinkle when stored in the shipping carton. Within a few days after the installation, the fabric will relax and the wrinkles will disappear.

 **WARNING** This product is designed primarily to enhance the appearance of the vehicle and to shield the occupants from ordinary weather conditions. Do not rely in any way on the components of this product to contain occupants within the vehicle, or to protect against injury or death in the event of an accident. This product will not protect the occupants from falling objects. Never operate the vehicle in excess of manufacturer's specifications.

#### WEAR SEAT BELTS AT ALL TIMES

Read and follow, precisely, all installation instructions provided when installing product. Failure to do so may result in a poor fit and could place occupants of the vehicle in a potentially dangerous situation.

# Supertop® – Installation Instructions

## Parts List and Hardware Identification

Top Fabric	Qty - 1
Quarter Window, Right	Qty - 1
Quarter Window, Left	Qty - 1
Rear Window	Qty - 1
Upper Door, Right	Qty - 1
Upper Door, Left	Qty - 1
Lower Door, Right	Qty - 1
Lower Door, Left	Qty - 1
Spacer Kit	Qty - 1

Windshield Retainer , Qty - 1,  
Part Number 378.36

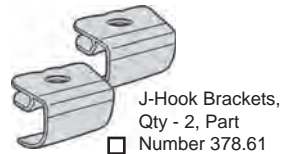
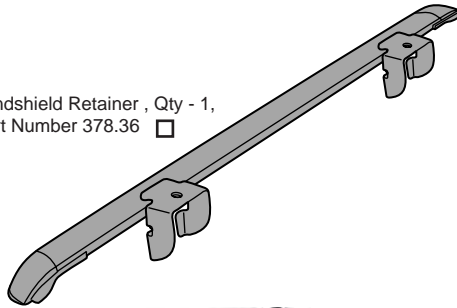

J-Hook Brackets,  
Qty - 2, Part  
Number 378.61

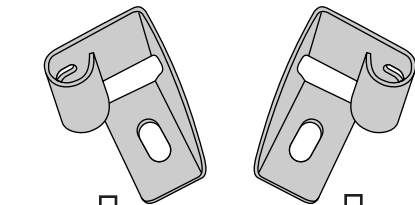

Windshield Bracket - Left,  
Qty - 1, Part Number 380.96

Windshield Bracket - Right,  
Qty - 1, Part Number 380.97



Bow Mount Bracket, Left, Qty - 1,  
Part Number 311.79



Bow Mount Bracket, Right, Qty - 1,  
Part Number 311.80



Tailgate Retainer Mount, Left,  
Qty - 1, Part Number 311.85



Tailgate Retainer Mount, Right,  
Qty - 1, Part Number 311.86

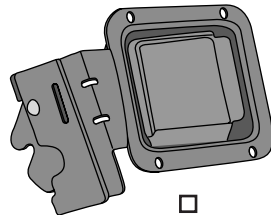

Latches - Rotary Paddle Handle - Rt.,  
Qty - 1, Lt., Qty - 1, Part Number 378.00

Bow Assembly - Left, Qty - 1,  
Part Number 385.99

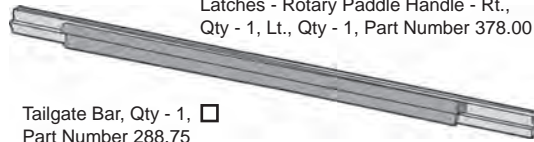
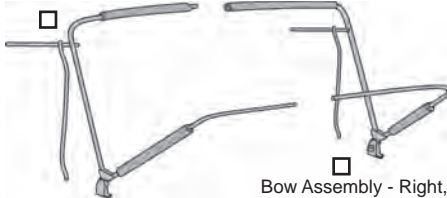

Tailgate Bar, Qty - 1,  
Part Number 288.75

Bow Assembly - Right, Qty - 1,  
Part Number 385.98

#8 x 1/2" Pan Head Washer Screw - Black, Qty - 4, Part Number 200.48

5/16-18 Tapping Plate, Qty - 4, Part Number 200.50

5/16" Washer, Qty - 8, Part Number 233.04

#10-24 Truss Head Machine Screw - Black, Qty - 10, Part Number 195.92

#10-24 Lock Nut - Black, Qty - 10, Part Number 195.93

5/16-18 x 1" Phillips Head Bolt, Qty - 4, Part Number 236.20

5/16" Acorn Nut, Qty - 4, Part Number 313.45

5/16 x 1-1/4" Bolt, Qty - 2, Part Number 378.59

1/8" Allen Wrench, Qty - 1, Part Number 276.68

# Supertop® – Installation Instructions

## 1 Install Windshield Brackets

Loosen the top screw on the A-Pillar Molding. Use a #40 Torx Driver to remove the outboard bolt that attaches the Sport Bar to the windshield. Slide the Windshield Bracket behind the A Pillar Molding and reinstall the bolt you removed to secure the bracket to the windshield. Re-tighten the top molding screw.

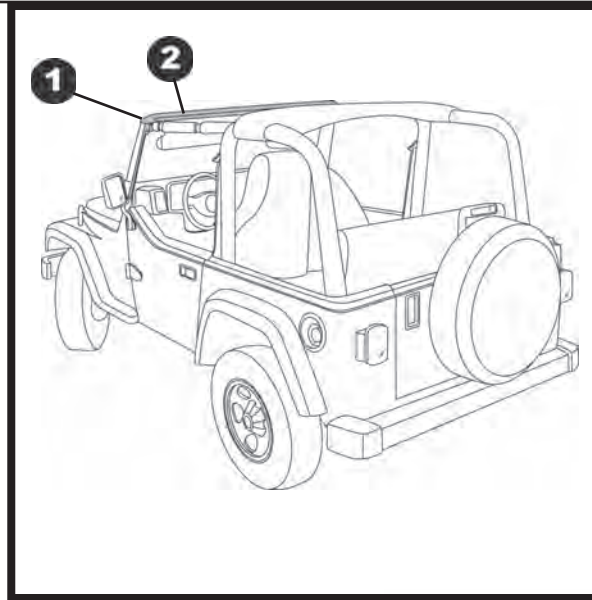
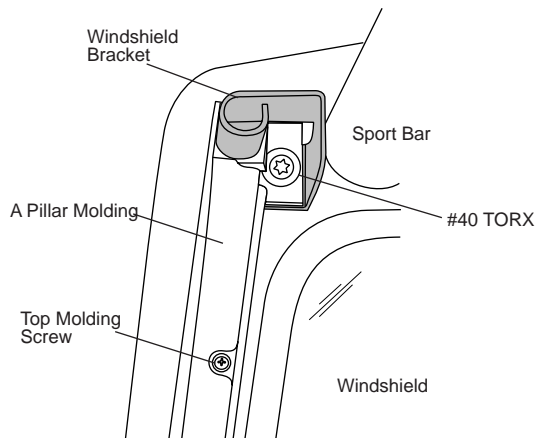

## 2 Install Windshield Retainer

Place the Windshield Retainer assembly on top of the bulb seal along the top of the Windshield.

Locate the two J-Hook Brackets in the parts kit. Orient a bracket with the hook toward the front and the threaded insert toward the top. Slide the bracket into one of the J-Hook Bracket Bases mounted to the Windshield Retainer and catch the hook in the slot in the windshield. Insert a 5/16" x 1-1/4" Bolt and a 5/16" Washer from the top of the base into the J-Hook Bracket to secure the bracket to the base. Repeat this on the other side of the vehicle.

**NOTE** While installing the Windshield Retainer/J-Hook Bracket Assembly, apply firm pressure toward the front of the vehicle to make sure that the assembly is installed correctly over the bulb seal.

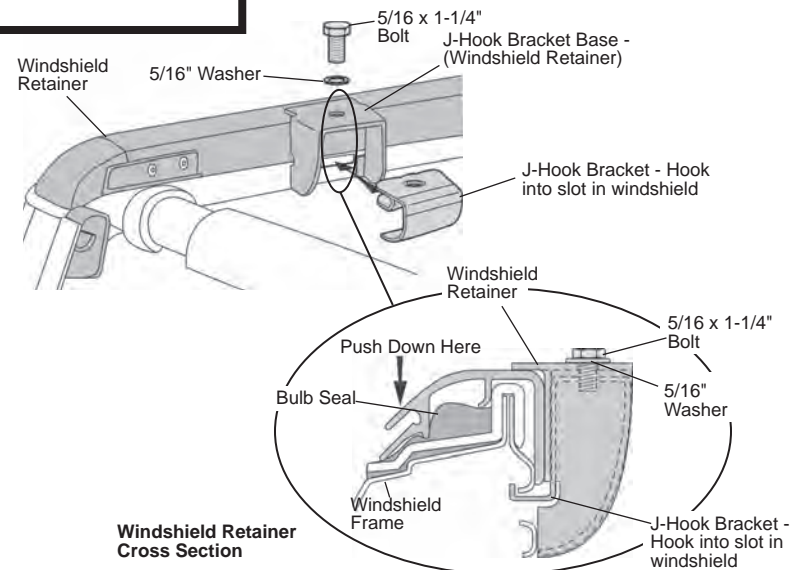

## Supertop® – Installation Instructions

### 3 Install Bow Mount Brackets

Locate the Left and Right Bow Mount Brackets in the parts kit. Locate the brackets behind the door opening on top of the body, with the curved Vertical Rod Retainer toward the front and opening to the inside of the vehicle. Align the holes in the bracket with the existing holes in the vehicle. Place a Tapping Plate under the ledge, lined up with each hole and install a 5/16-18 x 1" Phillips Head Bolt and a 5/16" Washer.

**NOTE** In order to fit properly with either full steel doors or soft upper doors, these brackets may need to be adjusted after the full top is installed.

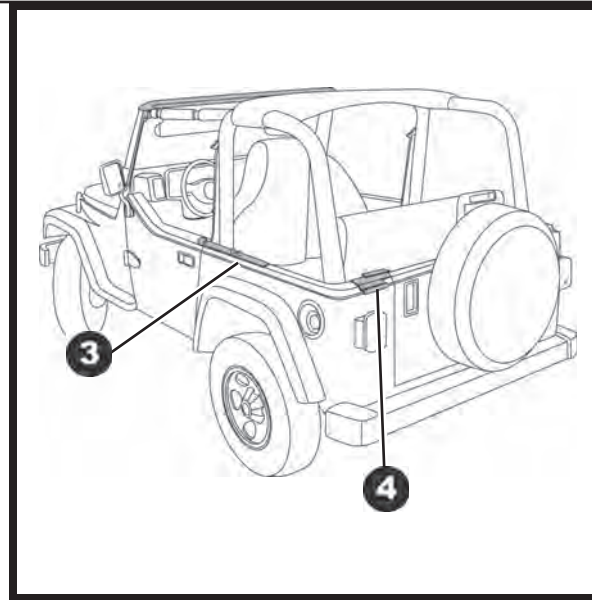

### 4 Install Tailgate Retainers

Locate the left and right Tailgate Retainer Mounts. Place the mounts flush with the edge of the tailgate opening. Install the Tailgate Retainer Mounts with two #8 x 1/2" Pan Head Washer Screws for each mount.

If your vehicle does not have holes at this location, align the Tailgate Retainer Mounts flush with the edge of the tailgate opening. Then mark the locations of the holes in the mounts, center punch and drill a 1/8" hole at the marked locations. Install the mounts with two #8 x 1/2" Pan Head Washer Screws for each mount.

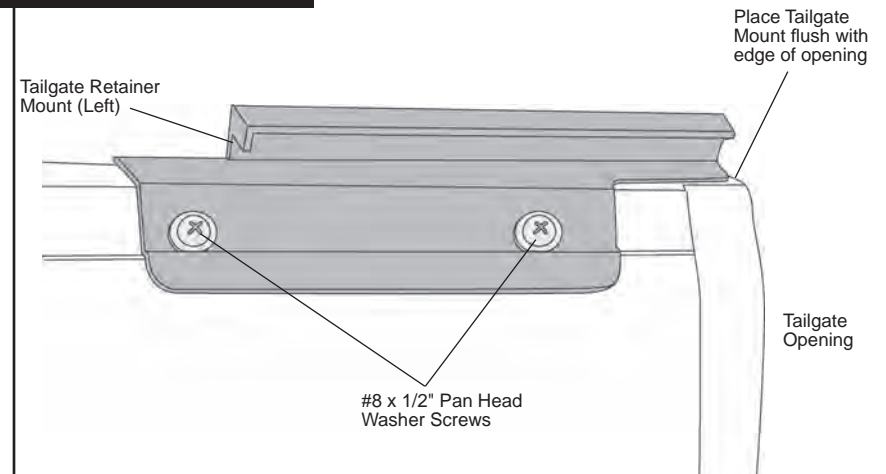
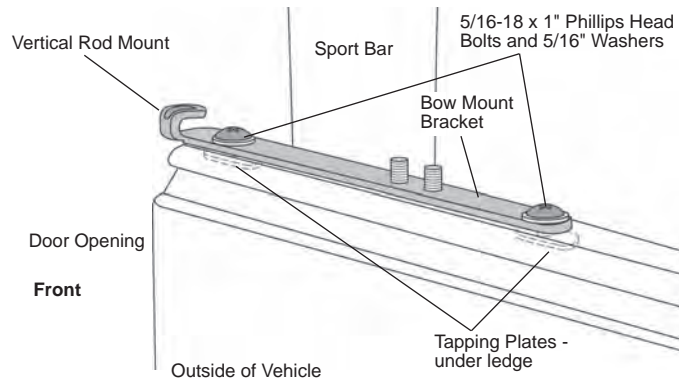

# Supertop® – Installation Instructions

## 5 Install Bow Assemblies

Locate the Left and Right Bow Assemblies in the parts kit. Orient the Bow Assemblies with the tab on the mount toward the rear of the vehicle. Place the holes in the mount over the studs in the Bow Mount Bracket and raise the bows to access the studs. Secure the Bow Assemblies to the Bow Mount Brackets with two 5/16 Acorn Nuts. Install the Bow Assemblies on both sides of the vehicle.

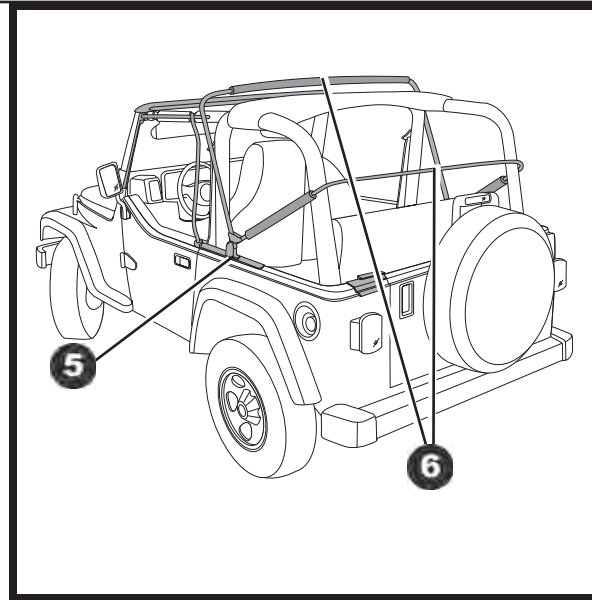
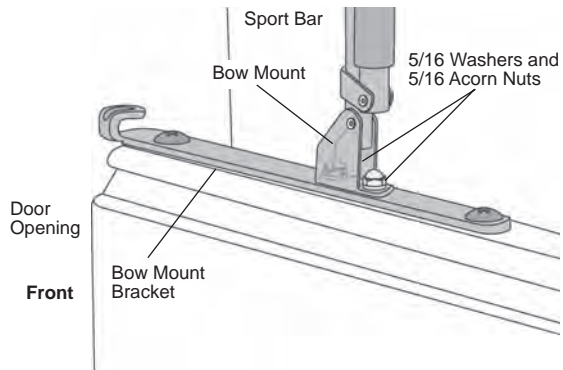

## 6 Assemble Bow Halves

Lay the bows down on top of the body. Start the male end of the Top (Front) Bow into the female end. Push forward on the bow until the two sides snap together. Slide the foam pieces on the bow together. Then start the male end of the Bottom (Rear) Bow into the female end and push forward on the bow until the two sides snap together.

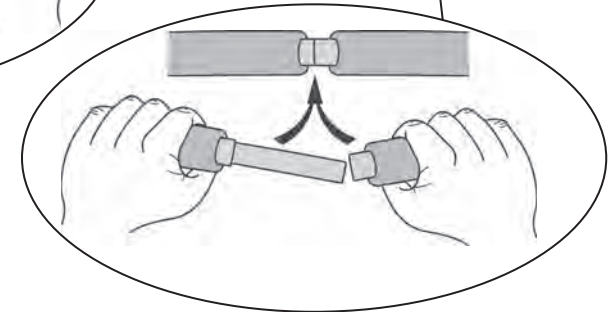
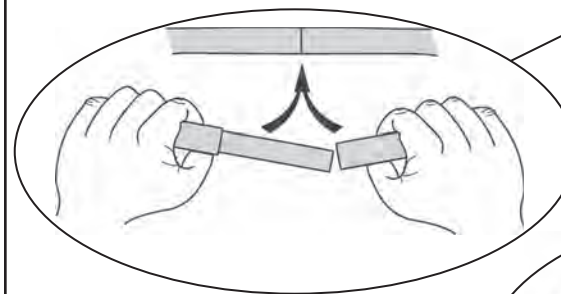
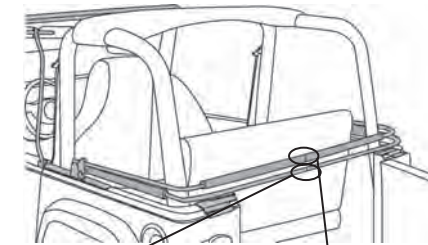



# Supertop® – Installation Instructions

## 7 Install Vertical Rod

Place the bottom of the Vertical Rod into the hole at the front of the Side Belt Rail.

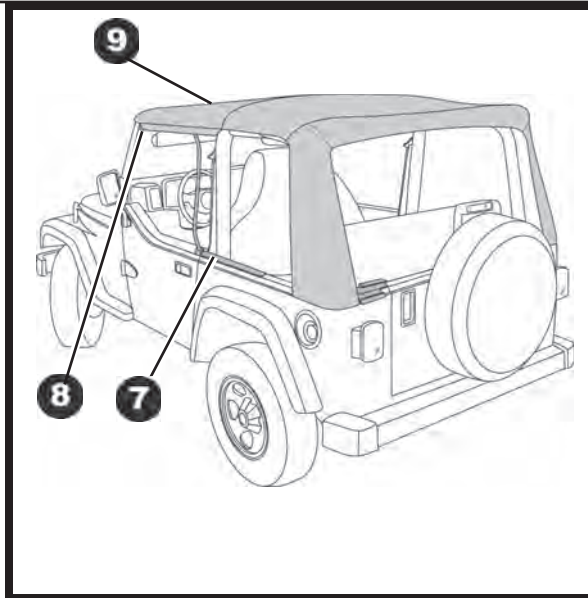
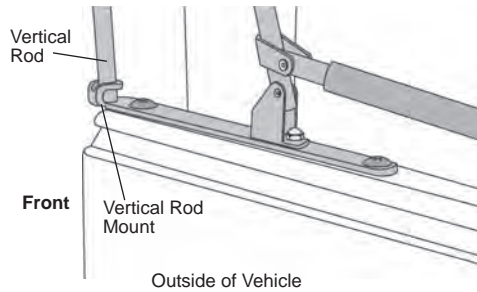

## 9 Install Top in Windshield Retainer

Locate the top and orient it on the vehicle. Drape the top over the bows and insert the plastic strip sewn along the front of the top into the windshield retainer. Do not catch the fabric in the retainer. Center the front of the deck on the vehicle so that it is an equal distance from the top of the windshield flange on both sides.

**NOTE** For best possible installation, check to make sure that the soft top is perfectly centered on the vehicle.

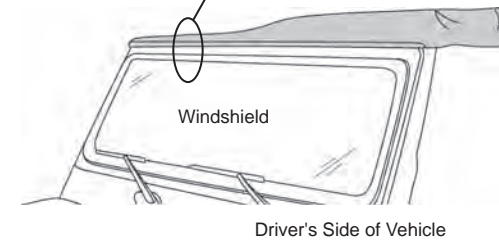
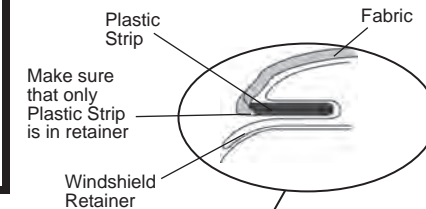

## 8 Install Horizontal Rod

Slip the end of the Horizontal Rod into the tube on the Windshield Bracket until the spring button on the rod pops up through the hole in the Windshield Bracket. If the spring button does not retain the Horizontal Rod in the Windshield Bracket, adjust the Windshield Bracket until it engages securely.

**NOTE** The pin must pop up through the hole in the Windshield Bracket for proper fit.

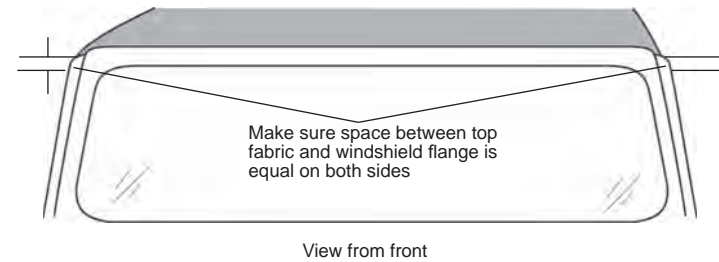
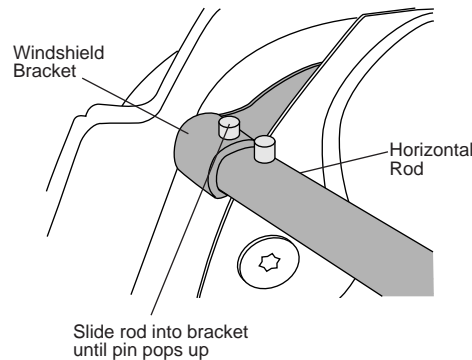

# Supertop® – Installation Instructions

## 10 Snap Top to Rear Bow

Fit the Rear Bow into the rear corners of the top. Snap the flaps to the six studs on the rear bow.

**NOTE** If the snaps don't appear to line up, push the rear bow forward to relieve the pressure on the bow. This will allow the snaps to line up more easily.

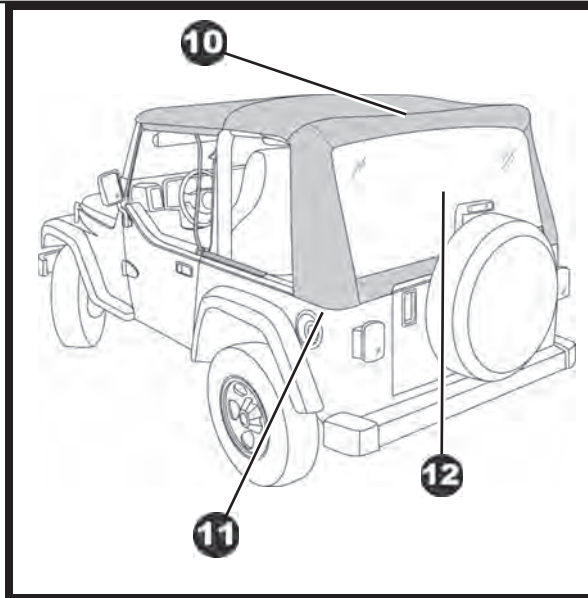
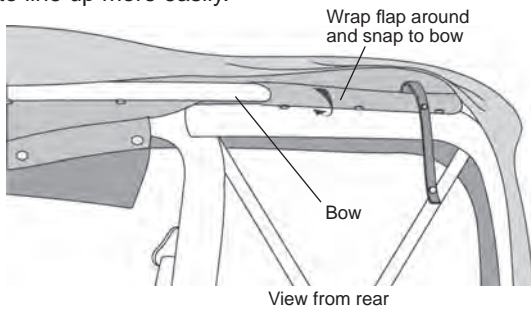

## 12 Install Rear Window

Locate the Rear Window in the parts kit. Orient it on the vehicle with the zippers toward the top. Catch the zipper on the driver's side, starting at the top corner and close the zipper a few inches. Then catch the top zipper, starting in the same corner and closing it a few inches. Finally, catch the zipper on the passenger side, starting at the top corner. Close all the zippers completely.

## 11 Secure Rear Corners to Belt Rails

Insert the plastic strips at rear corners of top into the corners of the belt rails that are built into the top edge of the vehicle.

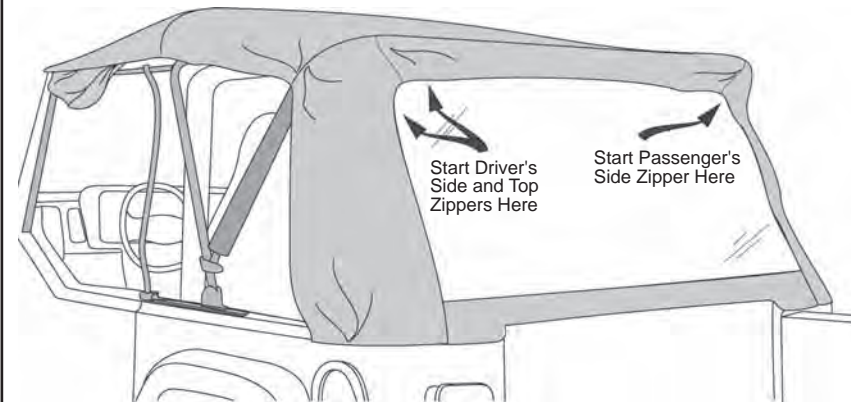
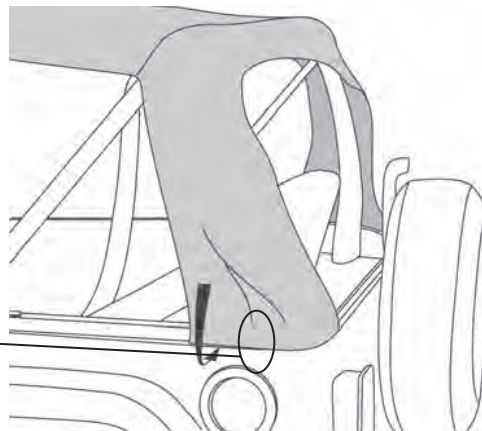
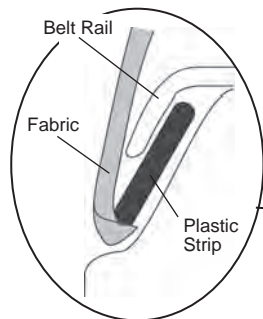

# Supertop® – Installation Instructions

## 13 Install Tailgate Bar

Open the tailgate. Orient the Tailgate Bar with the rubber bulb facing down, in order to form a seal with the top of the tailgate. Slide the groove in the Tailgate Bar onto the tube inside the bottom of the Rear Window. Roll the Tailgate Bar into the top of the Tailgate Retainer Mounts. Slip the plastic on the bottom of the Rear Window under the bottom part of the Tailgate Retainer Mounts. Close the rear curtain zippers.

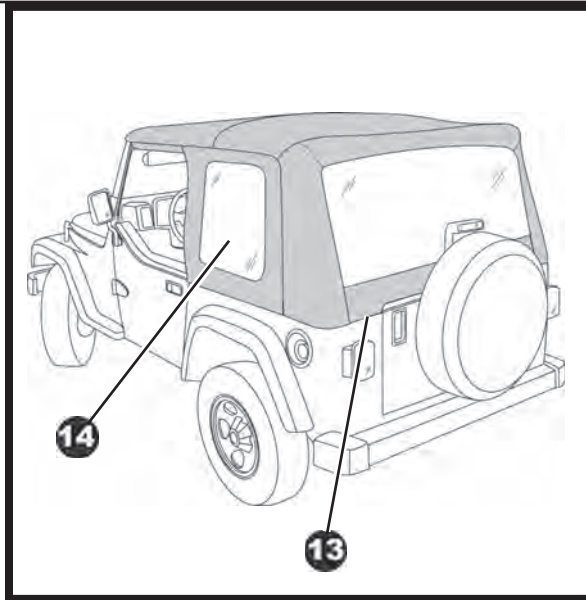
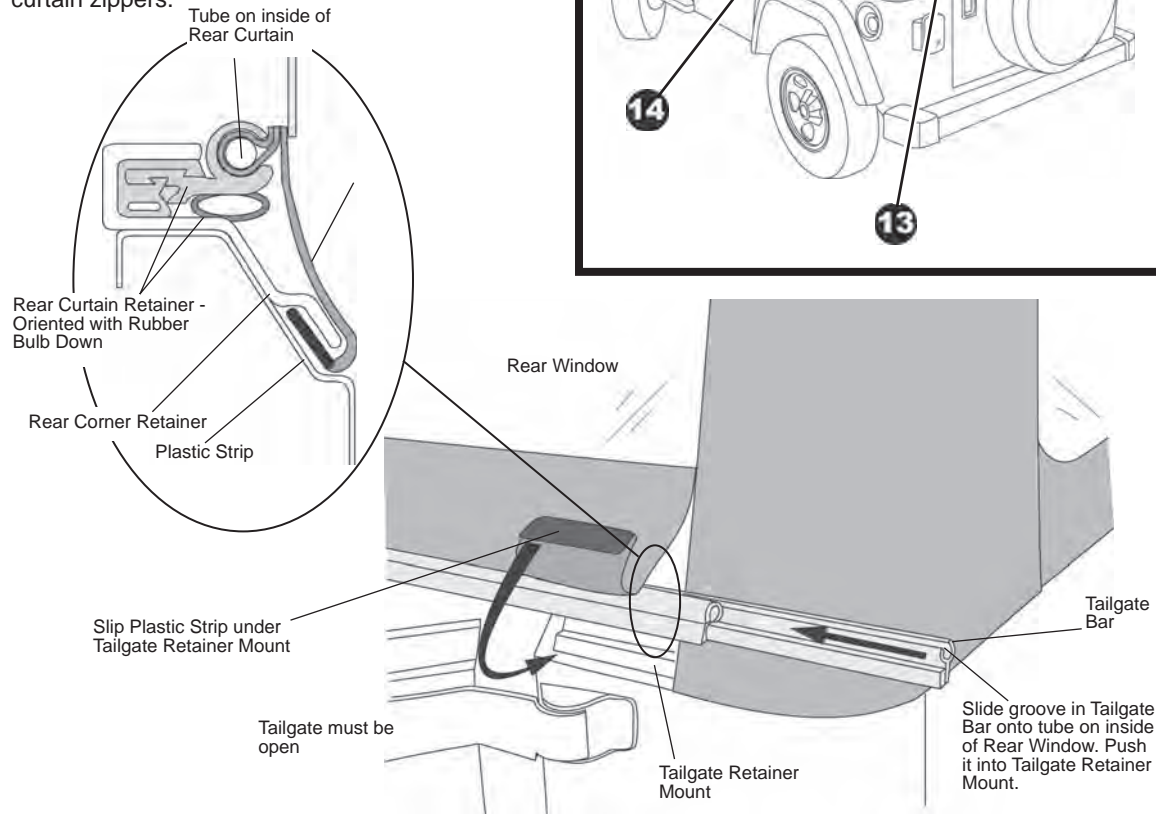

## 14 Install Quarter Windows

Locate the Left and Right Quarter Windows in the parts kit and orient them with the zippers toward the top and rear. Start the top zipper at the front corner and the rear zipper at the bottom rear corner. Close the zippers and tuck the top rear corner of the panel smoothly under the top.

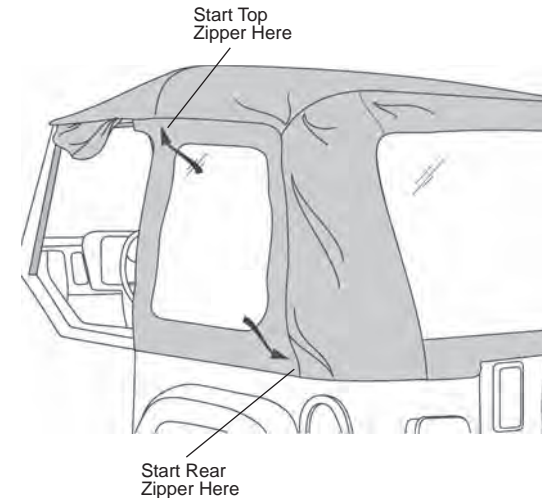



# Supertop® – Installation Instructions

## 15 Adjust Bows

Reach in under the Quarter Window and carefully slide the Rear Bow up on the Front Bow to increase the tension on the top. Be very careful not to scratch the windows. Insert the pin in the slide into the third hole (counting up from the bottom) of the four holes in the Front Bow.

**NOTE** If the top is extremely tight, slip the tab into a lower hole. The top will loosen up after a few hours in the sun. Then the pin may be inserted into a higher hole position.

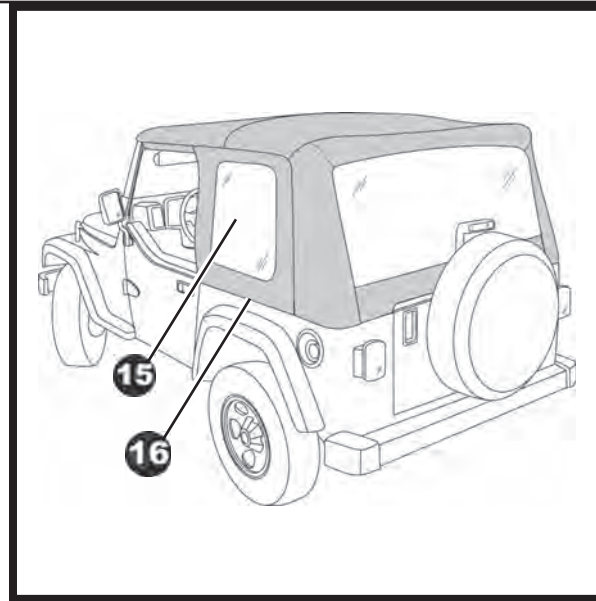
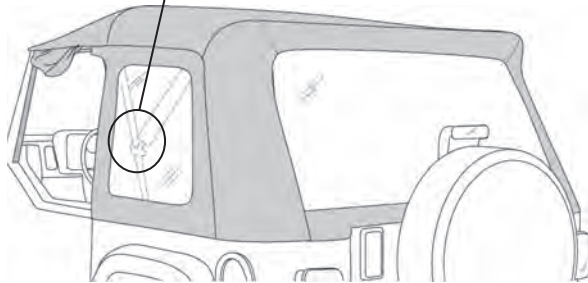
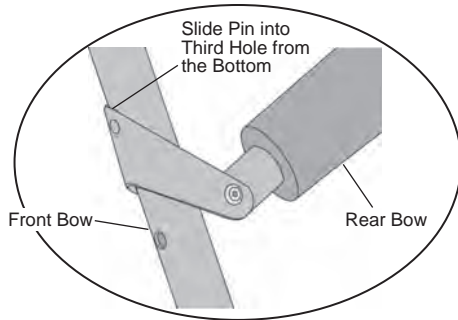

## 16 Secure Bottom of Quarter Window in Belt Rail

Slip the plastic strip on the bottom of the Quarter Window into the belt rail built into the vehicle.

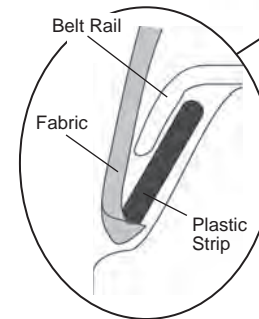
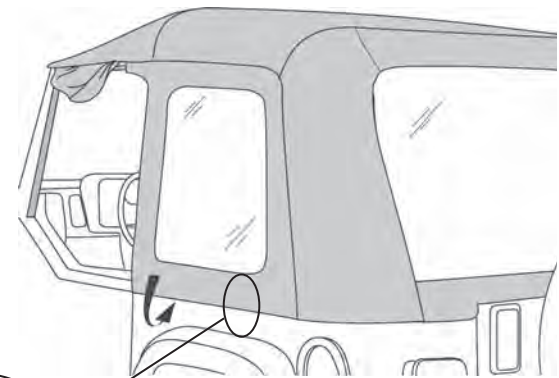

# Supertop® – Installation Instructions

## 17 Secure Front of Quarter Windows

Fasten the hook and loop strips at the top front of the Quarter Window. Wrap fabric flap on the front of the Quarter Window around the Vertical Rod (not the front bow) and fasten the hook and loop strips to each other.

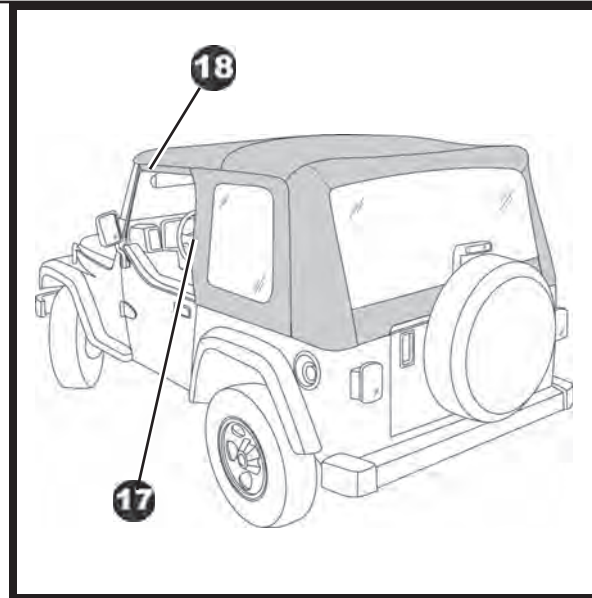
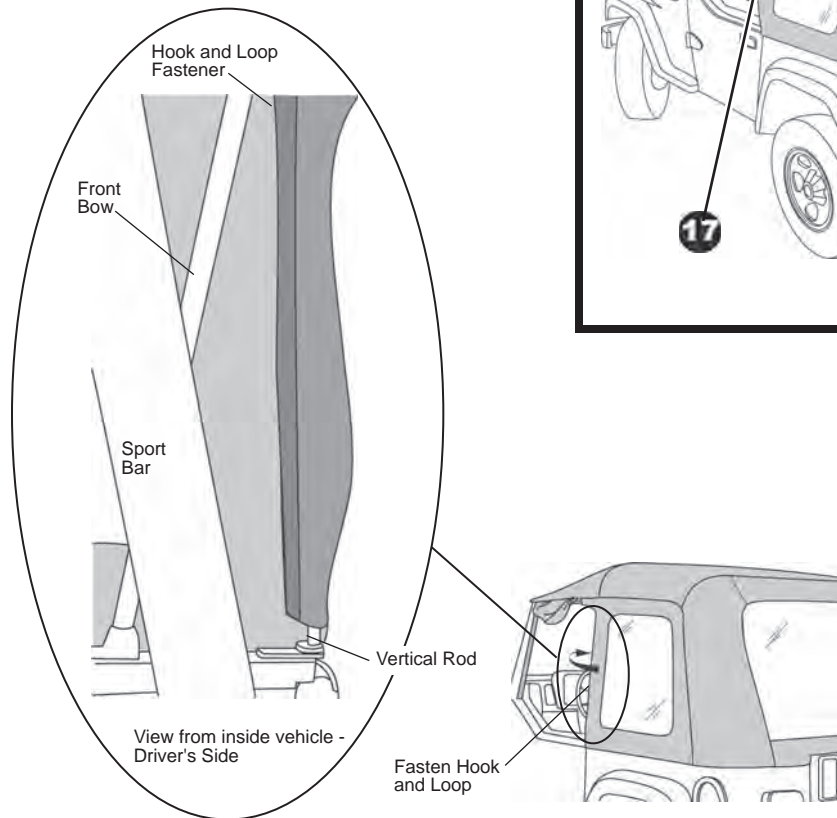

## 18 Secure Fabric above Door Openings

Wrap the flap, sewn to the top above each door, around the Horizontal Rod and fasten the hook and loop strips to each other. Tuck the front edge of the flap, next to the windshield, up under the Bulb Seal.

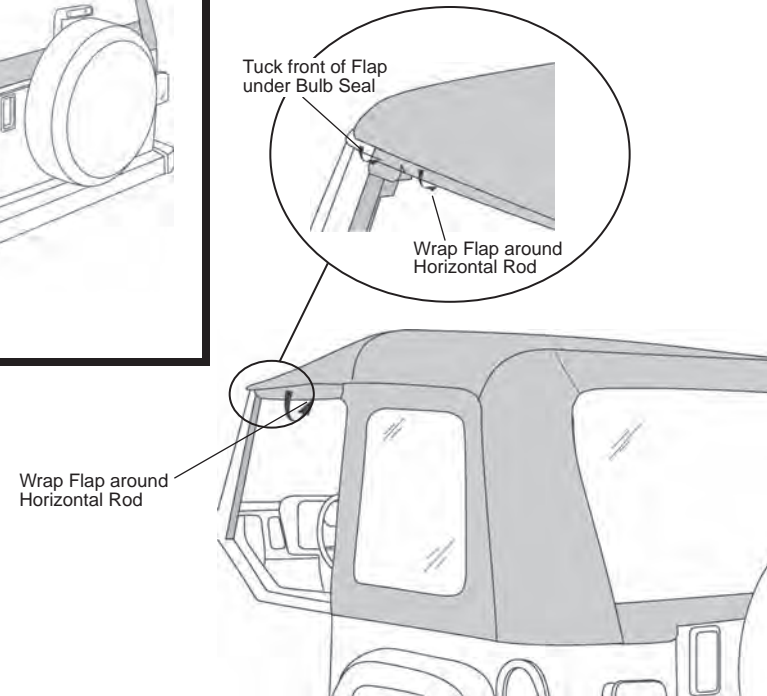

## 19 Final Check and Adjustment

Check the fit of the doors. If necessary, adjust the Bow Mount Brackets installed in Step 4 so that the doors fit properly. Tighten the bolts.

## Supertop® – Installation Instructions

### 20 Remove Factory Steel Door

Remove the factory steel door by removing the hinge pin nuts and lifting the door up and out of the body hinge. Remove any entry lights that are on when the doors are removed.



#### WARNING

It is important that the Paddle Hand must align correctly with the automobile manufacturer's original equipment steel latch pin located on the vehicle. Failure to properly install the paddle handle may result in the door accidentally opening. **IMPROPER CLOSURE COULD RESULT IN SERIOUS INJURY OR DEATH TO THE OCCUPANTS. WEAR SEAT BELTS AT ALL TIMES. DRIVE CAREFULLY.**



#### CAUTION

DO NOT attempt to adjust the Original Equipment Latch Pin (illustrated on

Page 3). Doing so could result in damage to the pin.

### 21 Install Latches in Lower Door

Remove the plastic caps from the upper door pins and from the Lower Door Hinge Pins. Locate the pre-cut "X" in the lower door panel where the Paddle Handle will fit into the mounting plate on the door frame. Fold the pre-cut fabric back and insert the Paddle Handle into the mounting plate so that the latch mechanism is inside of the vehicle and the Rotary Latch Mechanism is toward the rear of the door. Align the four holes in the Paddle Handle Assembly with the four holes in the mounting plate. Use a pointed tool to punch four holes in the fabric to match the holes in the Paddle Handle and the mounting plate. Insert four #10-24 Truss Head Machine Screws from the outside and secure them with #10-24 Locknuts. Do not tighten the screws until all four are in place. Check alignment of the Paddle Handle to the steel latch pin before tightening the screws. If out of alignment, align and retighten the screws securely. Trim the excess fabric around the Paddle Handle. Repeat for both lower doors.

#### NOTE

Important: You should check alignment of the Paddle Handle to the steel latch pin before tightening the screws. If out of alignment, align and retighten the screws securely.

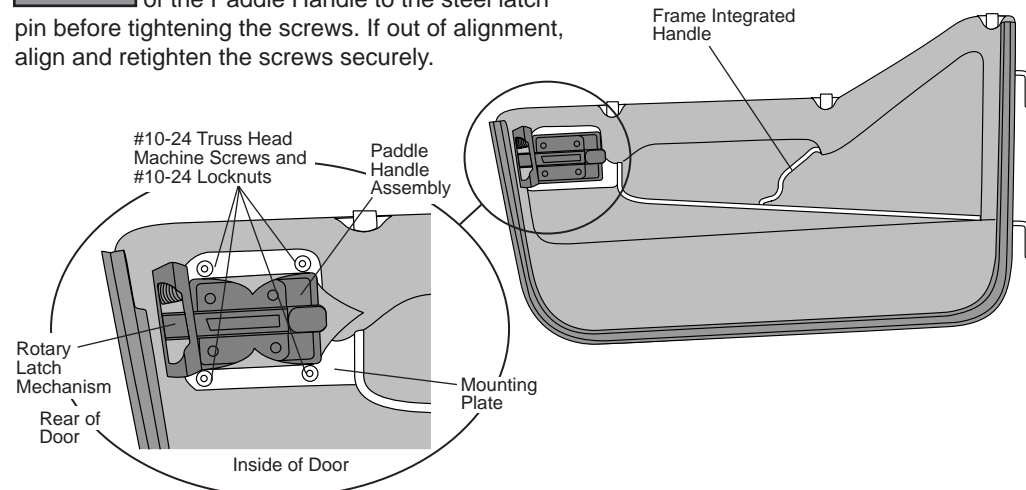

### 22 Install Lower Doors

Hold the door straight out from the vehicle with the hinge pins over the body hinges. Lower the pins into the hinges. Make sure that the pins are fully inserted into the body hinges. Close the door and check all sides to make sure that it fits properly against the body.

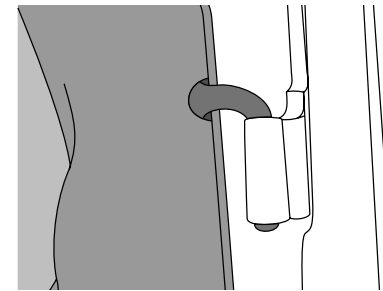

# Supertop® – Installation Instructions

## 23 Adjust Lower Doors

Locate the Lower Hinge Pin Adjustment Plate on the Lower Door frame. If the Lower Door needs to be adjusted for a better fit against the body, use a 7/16" Wrench to loosen the two nuts in the adjustment plate. Slide the Hinge Pin backward or forward as necessary for the best fit. Tighten the nuts. Readjust the Paddle Handle if necessary.

**NOTE** If the lower door pivot does not provide enough adjustability for correct latch adjustment (the door does not latch properly), follow the instructions in the enclosed spacer kit.

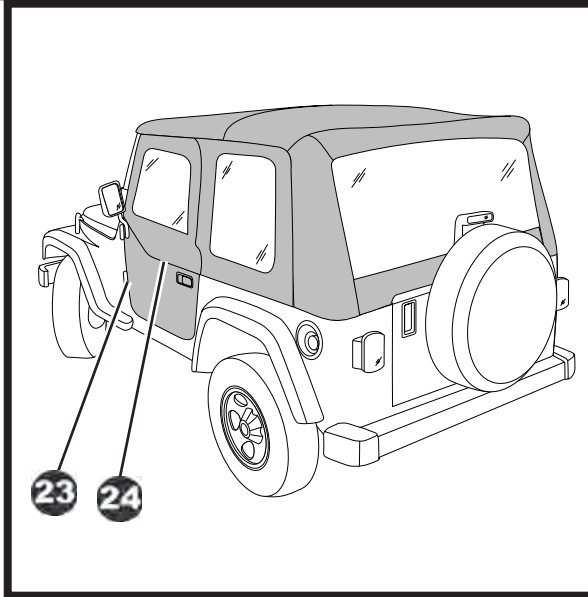
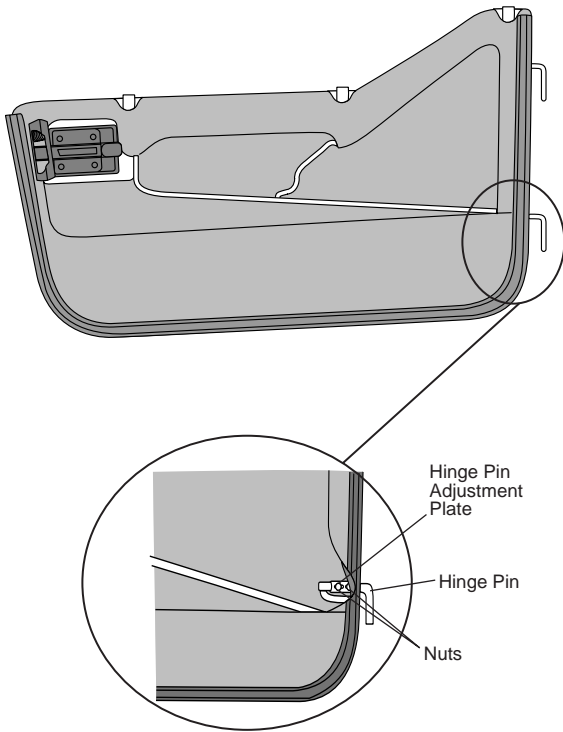

## 24 Install Upper Doors

Install the upper door into the lower door. Starting with the front pin, slip the pins into the sockets in the lower door. Make sure that the pins are well seated in the sockets. Close the door to check that it fits properly against the body. If necessary, use a 1/8" Allen Wrench to loosen the Collars on the front and rear upper door pins. The Collars will slide up or down as needed to provide the best fit of the Upper Door against the windshield. Attach the loop strip on the bottom of the upper door to the hook strip on the top of the lower door. If necessary for proper door fit, bend the door slightly.

**NOTE** Lubricating the upper door pins with a light weight oil will make it easier to install and remove the upper door.

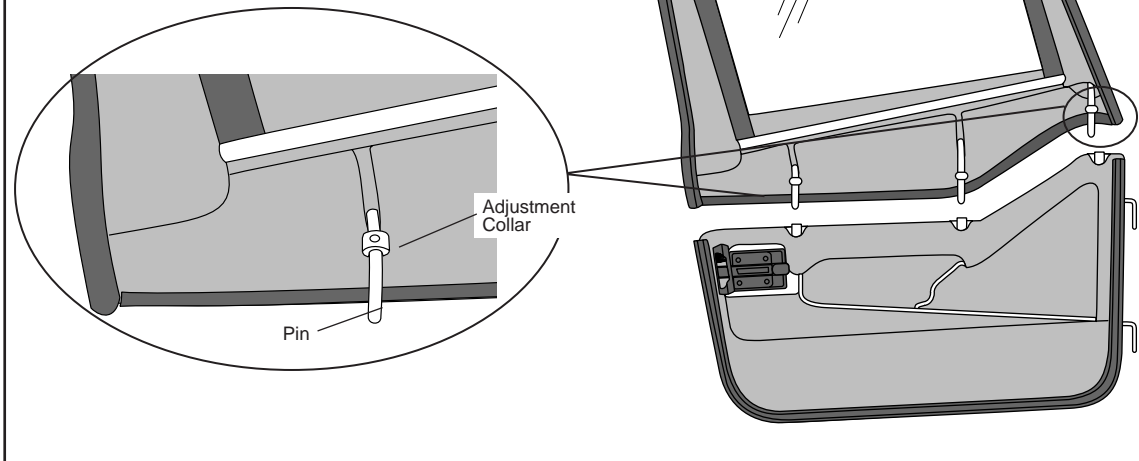



## Supertop® – Installation Instructions



### WARNING

When operating the vehicle without the Side Curtains, the Rear Curtain should be rolled up for proper ventilation.

## 25 Adjusting the Top

### Quarter Windows

To remove the Quarter Windows, unzip the rear and top zippers. Release the plastic strip from the retainer. Release the Hook and Loop Fasteners from around the Vertical Retainer.

### Rear Curtain

To roll up the Rear Curtain, remove the Tailgate Bar and start at the bottom, rolling it to the inside. Avoid wrinkles in the fabric and window. Secure it in place with the curtain straps inside of the top.

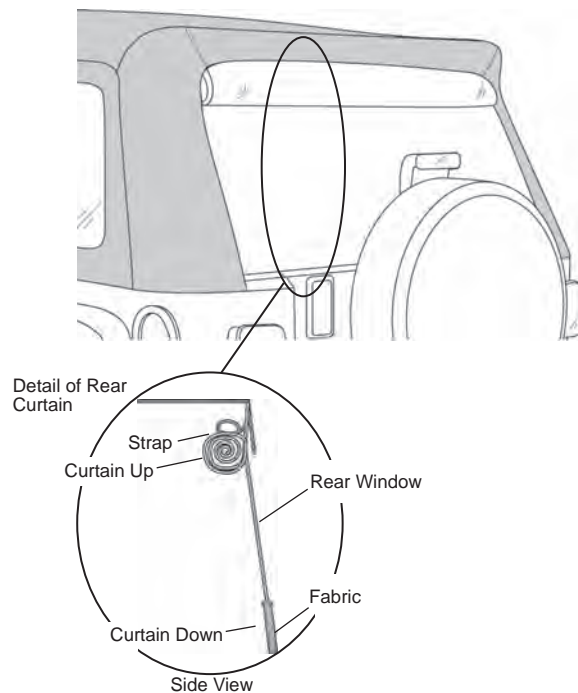

## 26 Folding the Top Down

Open the zippers at the rear of the Quarter Windows. Pull the plastic strip on the bottom of the Quarter Windows out of the Belt Rails. Leave the rear corners of the top attached to the Belt Rails. Unfasten the hook and loop strips at the front of the Quarter Windows, releasing them from the Vertical Retainer. Fold the Quarter Windows up onto the top and release the hook and loop fasteners on the flaps, above the doors. Unsnap the top from the rear bow.

Release the locking pins on the Bow Slides from the holes in the bow and slide the rear bow down to the Bow Mounts. Release the Horizontal Rod from the A-Pillar. Remove the Vertical Rod from the Vertical Retainer Mount and lay the bow assembly down on the rear of the vehicle.

Pull the plastic strip along the front of the top out of the Windshield Retainer and lay it down on the body. Make sure that the rear corners of the top are tucked under the rear bow. Fold the top in half from front to back and continue folding until the top is about 1 foot wide at the rear of the vehicle. Secure the top by clipping the Bow Tie Downs into the Side Belt Rails.

## 27 Removal of Soft Top for Open Air Driving

When operating the vehicle with the fabric top removed, it is very important that the supporting hardware system be disconnected from the A-Pillar molding and folded flat to the rear of the vehicle. The vertical and horizontal rods should be snapped into the plastic clips located on the inside of both bow mount brackets. Wrap the elastic straps around the bows and insert the plastic strip into the side belt rail. Never operate the vehicle with the fabric removed and the hardware in the fully erected position.

# Supertop® – Installation Instructions

## Care and Maintenance of your Bestop Product

Your Bestop product is made of the finest materials available. To keep it looking new and for the maximum possible wear, it will need periodic cleaning and maintenance.

**Washing:** The fabric should be washed often using soap, warm water and a soft bristle brush. Rinse with clear water to remove all traces of soap or use Bestop-recommended Bestop Cleaner and Bestop Protectant. Bestop Cleaner and Bestop Protectant are specially formulated to provide a total cleaning and protection system. Bestop Cleaner will not harm vehicle finish, is biodegradable and environmentally friendly. Bestop Protectant protects against UV-fading, cracking and hardening.

**Windows:** Keep windows clean to avoid scratching. DO NOT use a brush on the windows! Wash with a water-soaked cloth or sponge and a mild dishwashing detergent or use Bestop-recommended Bestop Vinyl Window Cleaner, which safely cleans and protects vinyl windows while helping prevent UV damage. NEVER WIPE THE WINDOWS WHEN THEY ARE DRY. Be careful when cleaning snow or frost from the vinyl windows since they are easily scratched and may crack at low temperatures. DO NOT roll the sides or rear window in cold weather. The windows become stiff and will crack.

**Zippers:** Keeping the zipper cleaned and lubricated with a silicone lubricant will help prevent damage and keep the zippers in a smooth working condition. If a zipper opens behind the slider, the slider may have been spread apart. This problem can usually be repaired by using an ordinary pair of pliers to bring the sides back into parallel. Return slider to the end of the zipper in the normal Open position. Squeeze lightly at first and test the zipper. If the zipper continues to remain open squeeze more firmly with the pliers and try the zipper again. Repeat this procedure until the zipper operates correctly.

**Water:** Seeping through at the seams may be stopped by applying 3-M Scotchgard® on the inside of the seams. Rips in the fabric may be repaired with Bondex® iron on patches. Iron the patches to the Inside of the top, carefully following the Bondex® instructions.

**Snaps:** Keep snaps cleaned and lubricated with silicone to help prevent snaps from sticking to the studs. If a snap does become stuck to a stud, use a screwdriver and GENTLY pry apart to prevent permanent damage to the snap or the top fabric.

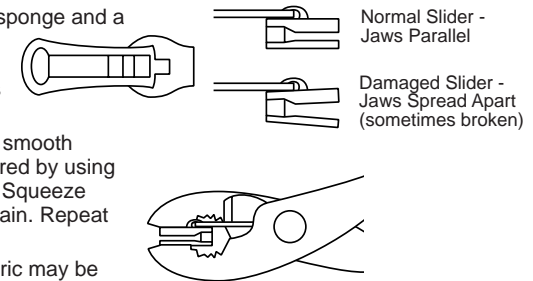

## LIMITED WARRANTY

We warrant our product to be free from defects in material and workmanship, for the terms specified below, provided there has been normal use and proper maintenance. This warranty applies to the original purchaser only. All remedies under this warranty are limited to the repair or replacement of any item or items found by the factory to be defective within the time period specified. If you have a warranty claim, first you must call our factory at the number below for instructions. You must retain proof of purchase and submit a copy with any items returned for warranty work. Upon completion of warranty work, if any, we will return the repaired or replaced item or items to you freight prepaid. Damage to our products caused by accidents, fire, vandalism, negligence, misinstallation, misuse, Acts of God, or by defective parts not manufactured by us, is not covered under this warranty.

THE WARRANTY TIME PERIOD IS AS FOLLOWS FOR REPLACE-A-TOP™, SAILCLOTH REPLACE-A-TOP™, SUPERTOP®, SUPERTOP® REPLACEMENT SKINS, SUNRIDER®, AND TIGERTOP®: TWO YEARS FROM DATE OF PURCHASE.

THE WARRANTY TIME PERIOD IS AS FOLLOWS FOR ALL OTHER "SOFT GOODS" MANUFACTURED BY OUR COMPANY (USING PRIMARILY VINYL, PLASTICS, AND/OR FOAM): ONE YEAR FROM DATE OF PURCHASE.

THE WARRANTY TIME PERIOD IS AS FOLLOWS FOR ALL OTHER "HARD GOODS" MANUFACTURED BY OUR COMPANY (USING PRIMARILY METALS, PLASTICS, AND/OR FIBERGLASS): ONE YEAR FROM DATE OF PURCHASE.

ANY IMPLIED WARRANTIES OF MERCHANTABILITY AND/OR FITNESS FOR A PARTICULAR PURPOSE CREATED HEREBY ARE LIMITED IN DURATION TO THE SAME DURATION AND SCOPE AS THE EXPRESS WRITTEN WARRANTY. OUR COMPANY SHALL NOT BE LIABLE FOR ANY INCIDENTAL OR CONSEQUENTIAL DAMAGE.

Some states do not allow limitations on how long an implied warranty lasts, or the exclusion or limitation of incidental or consequential damages, so the above limitations or exclusions may not apply to you. This warranty gives you specific legal rights, and you may also have other rights which vary from state to state.



For further information or request for warranty work, please contact:

Bestop Inc., Customer Service  
Toll-Free: (800)845-3567  
Main: (303)465-1755  
E-mail: [csbestop@Bestop.com](mailto:csbestop@Bestop.com)  
Website: [www.Bestop.com](http://www.Bestop.com)