



# Installation Instructions PowerBoard



Automatic Retracting Running Board









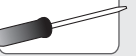

## Vehicle Application

• Dodge Ram Quad Cab Pickup  
2002 - 2008  
Part Number: 75101-15

• Dodge Ram Mega Cab Pickup  
2006 - 2009  
Part Number: 75118-15

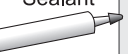
[www.Bestop.com](http://www.Bestop.com) - We're here to help! Visit our web site and click on "Ask a Question". Click here for more [Truck Accessories by Bestop](#).

<b>INSTALLATION TIME</b>	<b>SKILL LEVEL</b>
	
<b>4 Hours</b>	<b>4 - Difficult</b>

TOOLS				
 Tape Measure	 Flat-Head Screwdriver	 Phillips Screwdriver	 Power Drill 1/8" Drill Bits	 Wrench 13 mm
 Crimp Tool	 Silicone Sealant	 Allen Wrench 1/8" and 3/16"	 Rivet Gun	 Safety Glasses



**! WARNING** The manufacturer strongly recommends that this product be professionally installed.

**! WARNING** Failure to carefully follow the electrical installation steps could result in severe electrical shock which could harm the installer and/or damage the vehicle.

**! WARNING** Do not rely in any way on the components of this product to protect against injury or death in the event of an accident. Never operate the vehicle in excess of manufacturer's specifications.

### WEAR SEAT BELTS AT ALL TIMES

Read and follow, precisely, all installation instructions provided when installing product. Failure to do so may result in a poor fit and could place occupants of the vehicle in a potentially dangerous situation.

# PowerBoard – Installation Instructions

## Parts List and Hardware Identification

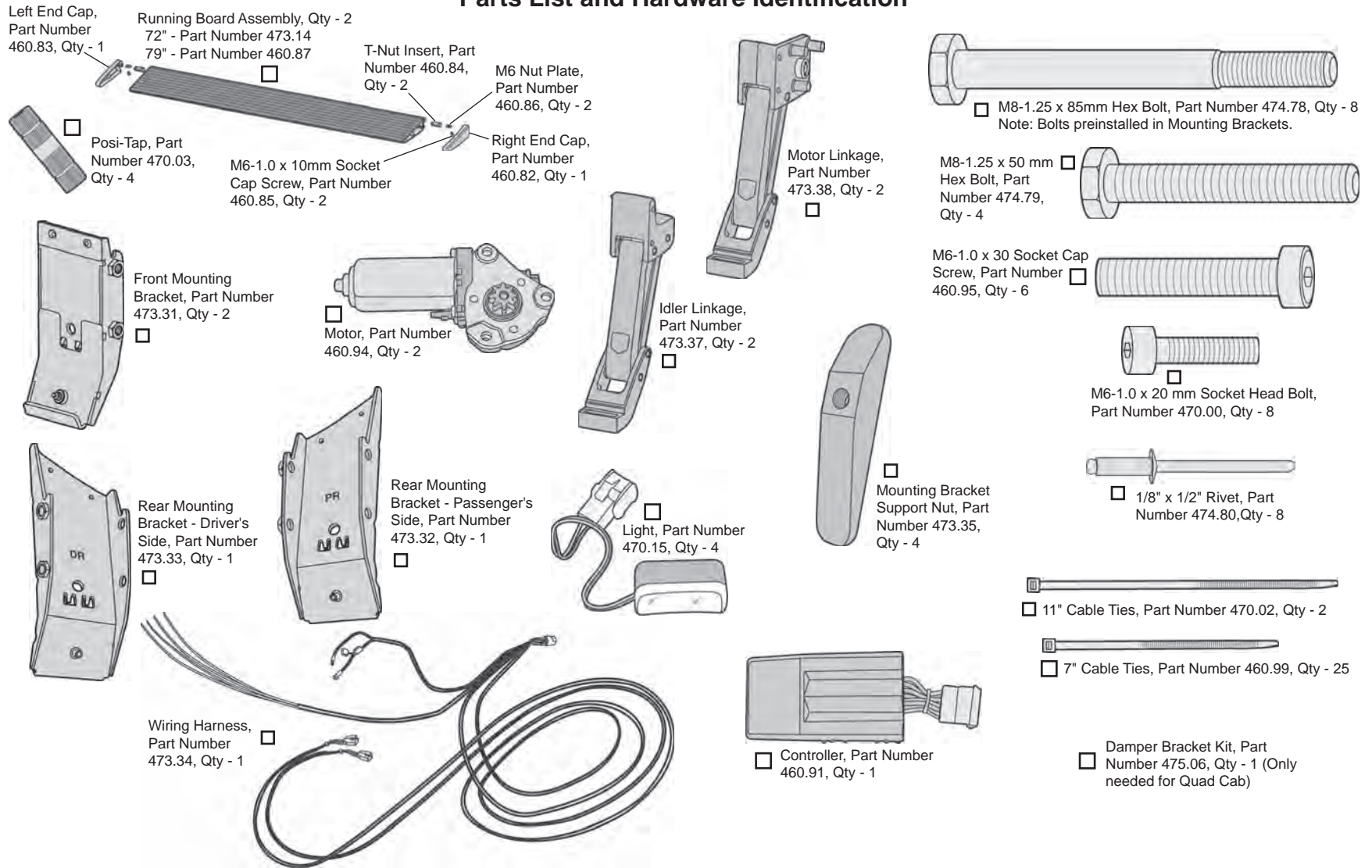

# PowerBoard – Installation Instructions

**NOTE Quad Cab Only -**

Before beginning this installation, follow the instructions in the Damper Bracket Kit to relocate the dampers on Quad Cabs.

## 1 Remove Plugs - Driver's Side

Counting from the front, locate the third (3rd) and seventh (7th) plugs on the inner sill for a Quad Cab. For a Mega Cab locate the third (3rd) and eighth (8th) plugs. Use a flat screwdriver to pry them out.

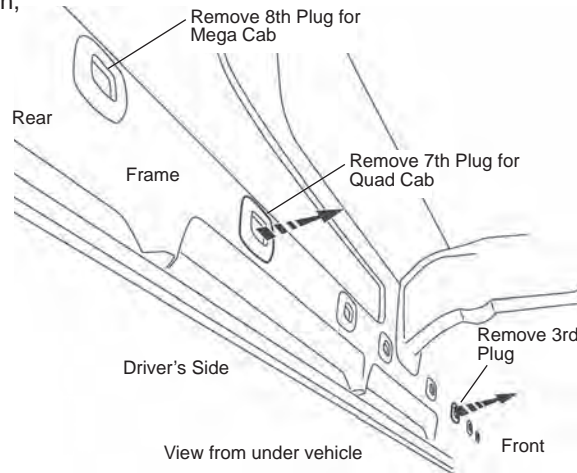

## 2 Assemble Rear Mounting Bracket Assembly - Driver's Side

Locate the Rear Mounting Brackets and the Mounting Bracket Support Nuts in the parts kit. Use a Medium Hex Bolt to attach a Support Nut to the back of the Rear Mounting Bracket.

If you have a Mega Cab, remove the tape and cut as indicated for the Mega Cab Rear Bracket, if necessary.

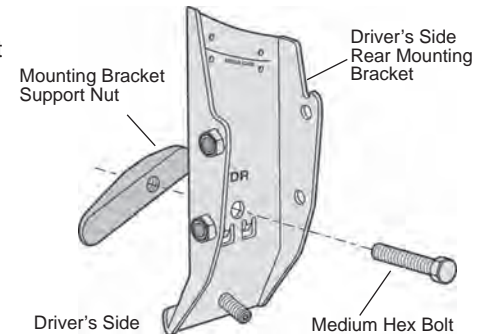

## 3 Install Rear Mounting Bracket Assembly - Driver's Side

Slide the Support Nut on the Rear Mounting Bracket Assembly into the rear hole where the plug was removed. Hook the tabs on the bracket over the edge of the hole to help secure the bracket to the frame. Pull back on the Hex Bolt to snug the nut and bracket up to each other and use a 13mm wrench to tighten the bolt to 16 ft./lbs. (22 Nm).

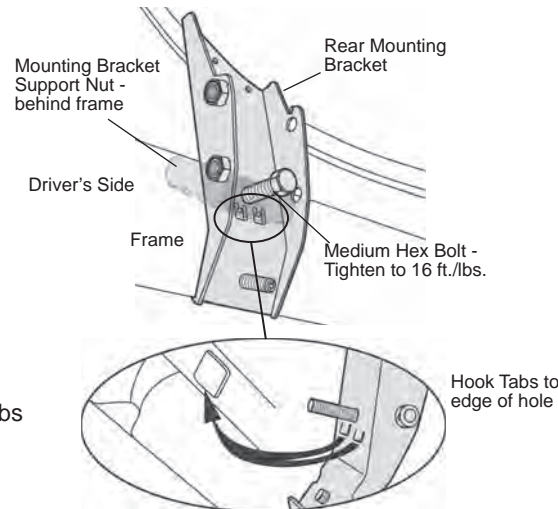

**NOTE** Make sure that the two tabs in the bracket rest on the edge of the hole in the sheet metal.

## 4 Install Rear Mounting Bracket Assembly - Driver's Side

Use the two small holes in the Rear Mounting Bracket as templates to drill two 1/8" holes. Paint the edges of the holes with Corrosion Protection Paint to prevent rust.

Install a Rivet in each hole. Use a 1/8" Allen Wrench to tighten the set screw on the bracket to 1.5 ft./lbs. (2 Nm).

**NOTE** Make sure the bracket is flush with the inner sill before riveting.

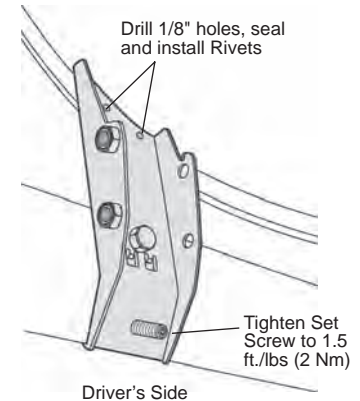

## PowerBoard – Installation Instructions

### 5 Install Front Mounting Brackets

Repeat Steps 1-4 with the Front Mounting Bracket.

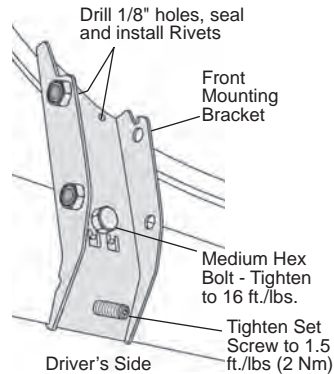

### 6 Install Arms - Driver's Side

Orient the Front and Rear Arms to the brackets so the platform faces outside the vehicle to support the Step. Install the arms in the brackets with two Large Hex Bolts for each arm. Tighten the bolts to 16 ft./lbs. (22 Nm).

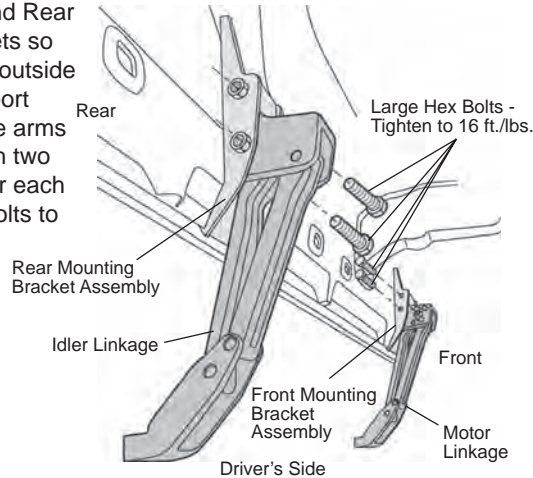

### 7 Install Passenger's Side Brackets and Arms

Repeat Steps 1-6 on the passenger side.

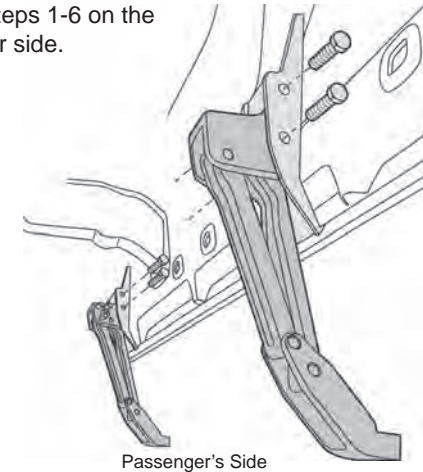

### 8 Install Controller and Wiring Harness

Loosely wrap 11" Cable Ties around harness in engine compartment. Slide the Controller through the Cable Ties and tighten. Attach the Wiring Harness to the Controller.

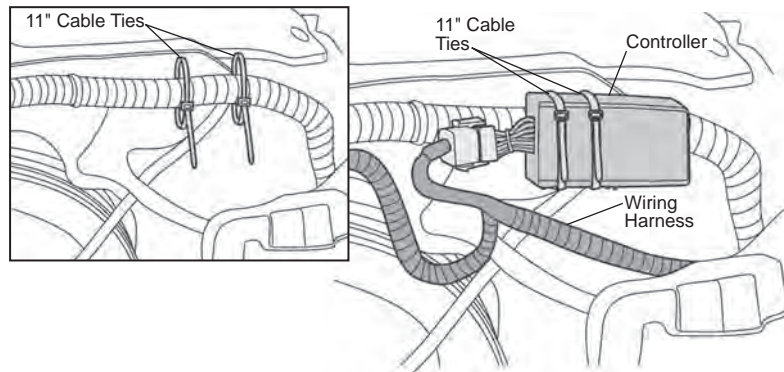

**! WARNING** Remove the fuse from the Wiring Harness.

### 9 Remove Fuse from Wiring Harness

Remove the fuse from the Wiring Harness. Failure to do so could result in severe electrical shock which could harm the installer and/or damage the vehicle.

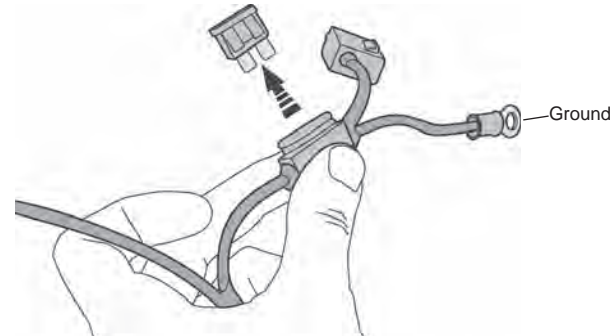

## PowerBoard – Installation Instructions

### 10 Attach Power Leads

Attach the red power lead to the positive battery terminal and black lead to the body ground.

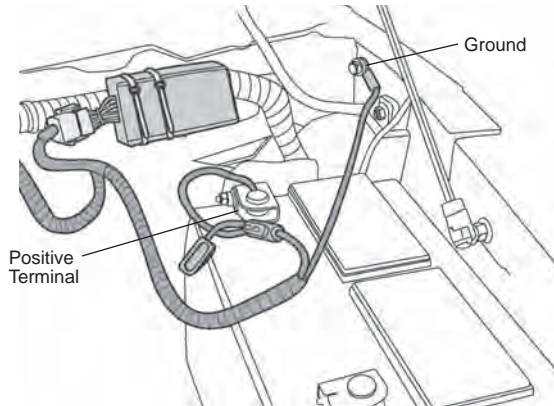

### 11 Secure Wiring Harness

Route the longer leg of the harness that terminates in a plug across the front of the engine compartment and down to the motor on the passenger side step. Route the shorter leg to the motor on the driver's side step. Use the 7" Cable Ties in the parts kit to secure the harness out of the way.

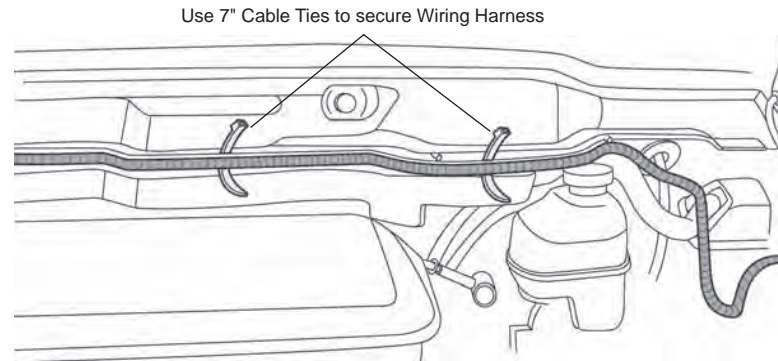

### 12 Install Wiring Harness

Route the leg of the Wiring Harness with the unterminated wires down to the grommet access through the firewall. Drill a hole in the grommet and feed the wires through the firewall.

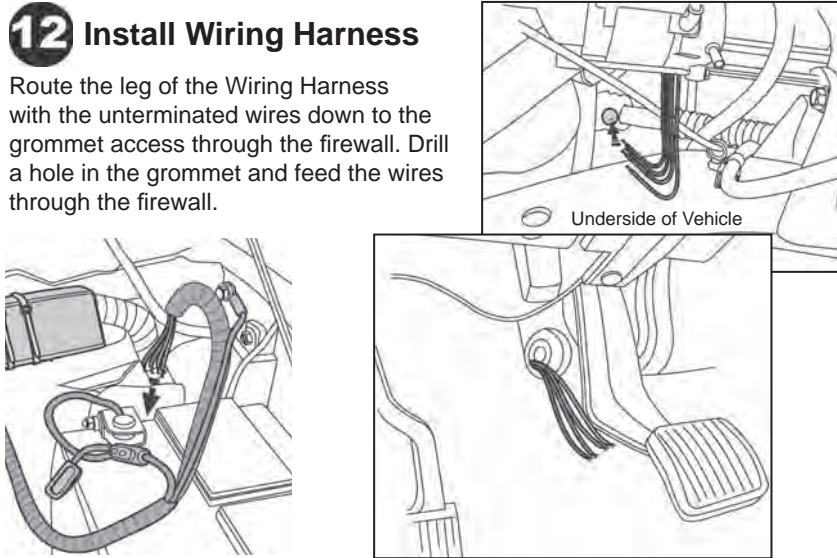

### 13 Remove Plastic Panels

Remove the plastic panels below the steering wheel. Remove the metal panel under the plastic panel. Model years 2002 - 2005 will not have this panel.

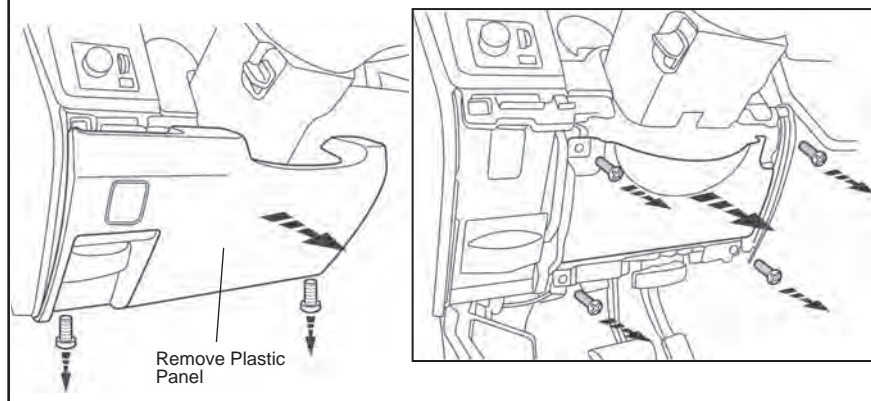

# PowerBoard – Installation Instructions

## 14 Locate Wiring Harness

Locate the bundle of wires high and to the left of the steering column, behind the dash light dimmer switch. 2002 - 2005 model years will find this bundle running down the right side of the steering column.

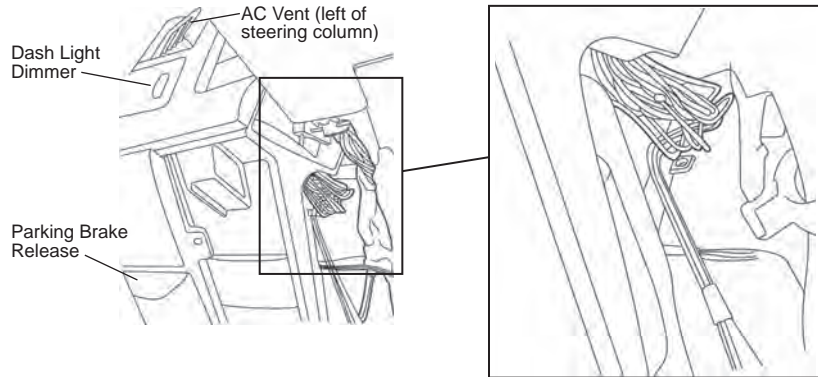

## 15 Install Wiring Harness

Pull the unterminated wires of the harness up to the harness.

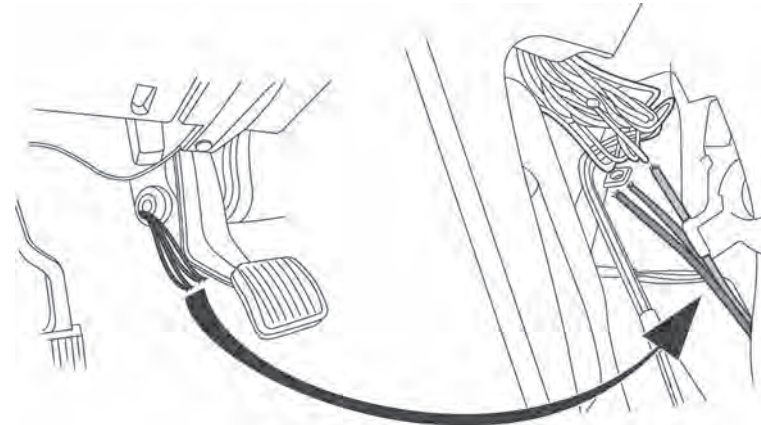

## 16 Wiring

Use the Posi-Taps™ to splice the PowerBoard trigger wires into the door ajar wires indicated for your vehicle model year.

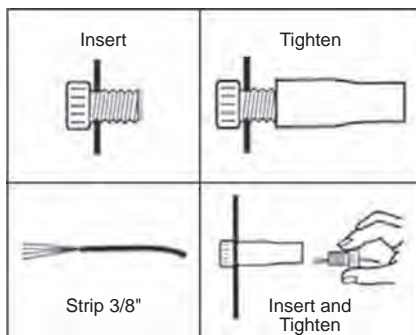

Posi-Tap™ Instructions

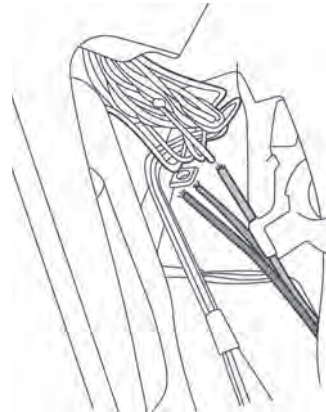

### 2004 – Current

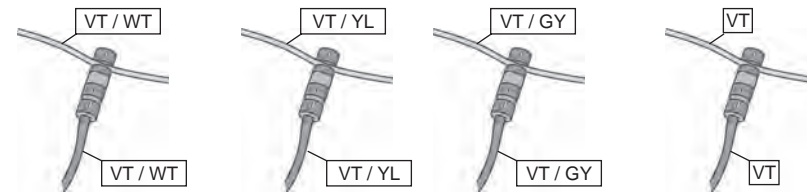

### 2002 – 2003

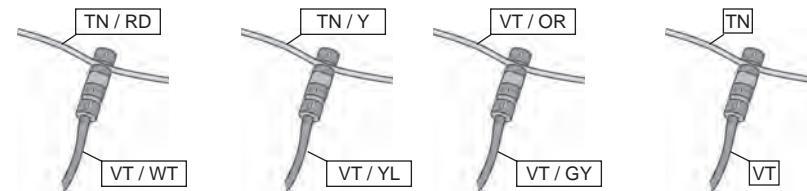

# PowerBoard – Installation Instructions

## 17 Install Wiring Harness

Route harness to motors and secure under vehicle with 7" Cable Ties.

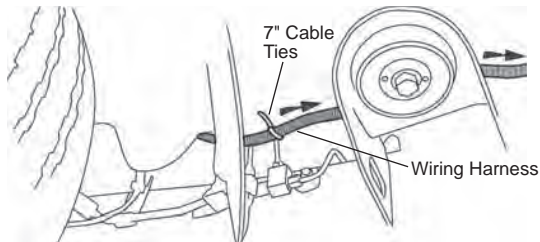

## 18 Install Lights

Clean the outboard surface of the of the Linkage below the bottom mounting bolt. Peel the adhesive liner off the back of the Light and firmly press it 1/8" below the mounting bolt. Plug the light into the connector with the black and orange wires in the wire harness. Repeat with the other three lights. Secure loose wires with Cable Ties.

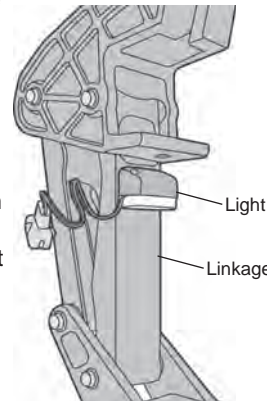

## 22 Install Running Boards

Orient the Running Boards on the vehicle aligning the rear of the board with the rear edge of the back doors. Mount the Steps to the linkages. Slide the mounting T-Nut into position. Install M6-1.0 x 20mm Socket Head Bolts to secure the boards. Use a 5mm Allen Wrench to tighten the bolts to 10 ft./lbs. Make sure the board moves up and down freely by hand. If it binds, loosen the linkage to body attachment bolts and adjust the linkage position until the boards move freely. Retighten the linkage to body attachment bolts.

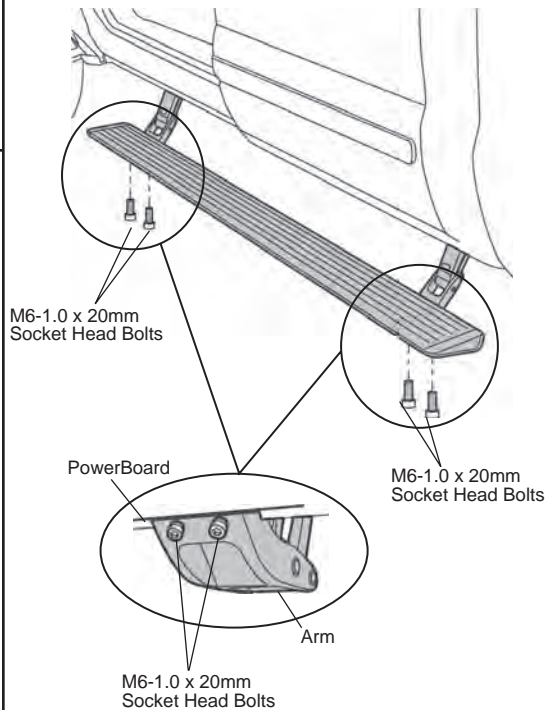

## 20 Install Motor

Slide Motor assembly onto drive shaft and mounting bosses of Motor Linkage assembly. Use three (3) M6-1.0 x 30mm Socket Cap Screws to secure Motor. Plug female connector into Motor. Wrap any exposed wires from the motor with electrical tape.

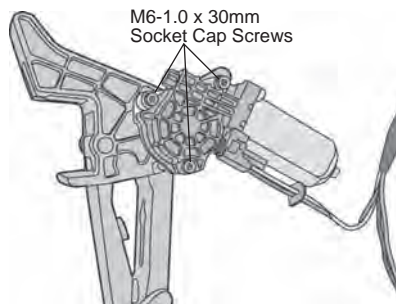

## 21 Reinstall Fuse

Reinstall the fuse in the harness.

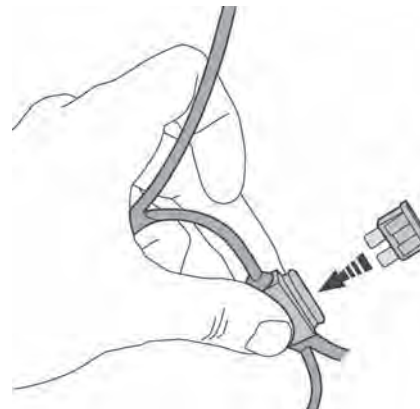

## PowerBoard – Installation Instructions

---

### 23 Test Doors

Open the doors to make sure that the PowerBoard drops into position on each side of the vehicle.

Reinstall any remaining trim panels.

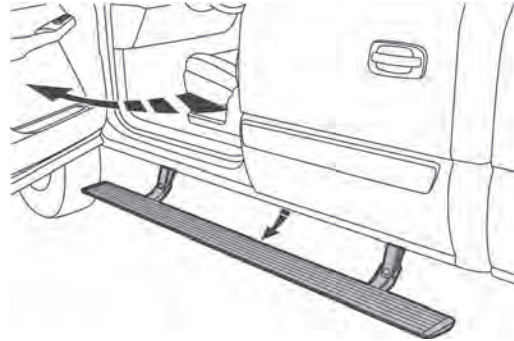

---

## LIMITED WARRANTY

We warrant our product to be free from defects in material and workmanship, for the terms specified below, provided there has been normal use and proper maintenance. This warranty applies to the original purchaser only. All remedies under this warranty are limited to the repair or replacement of any item or items found by the factory to be defective within the time period specified. If you have a warranty claim, first you must call our factory at the number below for instructions. You must retain proof of purchase and submit a copy with any items returned for warranty work. Upon completion of warranty work, if any, we will return the repaired or replaced item or items to you freight prepaid. Damage to our products caused by accidents, fire, vandalism, negligence, misinstallation, misuse, Acts of God, or by defective parts not manufactured by us, is not covered under this warranty.

THE WARRANTY TIME PERIOD IS AS FOLLOWS FOR ALL PowerBoards MANUFACTURED BY OUR COMPANY: THREE YEARS / 36,000 MILES FROM DATE OF PURCHASE.

ANY IMPLIED WARRANTIES OF MERCHANTABILITY AND/OR FITNESS FOR A PARTICULAR PURPOSE CREATED HEREBY ARE LIMITED IN DURATION TO THE SAME DURATION AND SCOPE AS THE EXPRESS WRITTEN WARRANTY. OUR COMPANY SHALL NOT BE LIABLE FOR ANY INCIDENTAL OR CONSEQUENTIAL DAMAGE.

Some states do not allow limitations on how long an implied warranty lasts, or the exclusion or limitation of incidental or consequential damages, so the above limitations or exclusions may not apply to you. This warranty gives you specific legal rights, and you may also have other rights which vary from state to state.

For further information or request for warranty work, please contact:

Bestop Inc. Customer Service  
Toll-Free: (800)845-3567  
Main: (303)465-1755  
E-mail: [csbestop@Bestop.com](mailto:csbestop@Bestop.com)  
Website: [www.Bestop.com](http://www.Bestop.com)

