





Installation Instructions PowerBoard







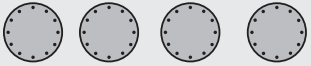

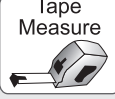

Automatic Retracting Running Board

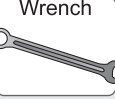
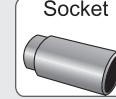
Vehicle Application

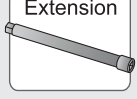
- Ford F150 Super Crew Cab
2009 – Current
Part Number: 75141-15

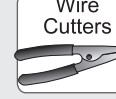
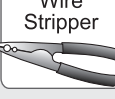
www.Bestop.com - We're here to help! Visit our web site and click on "Ask a Question". Click here for more [Truck Accessories by Bestop](#).

INSTALLATION TIME	SKILL LEVEL
 <p>4 Hours</p>	 <p>4 - Difficult</p>

TOOLS				
 <p>Tape Measure</p>	 <p>Flat-Head Screwdriver</p>	 <p>Phillips Screwdriver</p>	 <p>Wrench 13mm</p>	 <p>Socket 8mm, 10mm & 13mm</p>
 <p>Ratchet</p>	 <p>Extension</p>	 <p>Allen Wrench 3/16" & 4mm</p>	 <p>Crimp Tool</p>	 <p>Wire Cutters</p>
 <p>Wire Stripper</p>	 <p>Electrical Tape</p>	 <p>Silicone Sealant</p>	 <p>Safety Glasses</p>	



! WARNING The manufacturer strongly recommends that this product be professionally installed.

! WARNING Failure to carefully follow the electrical installation steps could result in severe electrical shock which could harm the installer and/or damage the vehicle.

! WARNING This product is designed primarily to enhance the appearance of the vehicle and to shield the occupants from ordinary weather conditions. Do not rely in any way on the components of this product to contain occupants within the vehicle, or to protect against injury or death in the event of an accident. This product will not protect the occupants from falling objects. Never operate the vehicle in excess of manufacturer's specifications.

WEAR SEAT BELTS AT ALL TIMES

Read and follow, precisely, all installation instructions provided when installing product. Failure to do so may result in a poor fit and could place occupants of the vehicle in a potentially dangerous situation.

PowerBoard – Installation Instructions

Parts List and Hardware Identification

Left End Cap, Part Number 460.83, Qty - 1

Running Board Assembly, Qty - 2
79" - Part Number 460.87
72" - Part Number 473.14

T-Nut Insert, Part Number 460.84, Qty - 2

M6 Nut Plate, Part Number 460.86, Qty - 2

Right End Cap, Part Number 460.82, Qty - 1

M6-1.0 x 10mm Socket Cap Screw, Part Number 460.85, Qty - 2

Idle Linkage, Part Number 473.62, Qty - 2

Motor, Part Number 460.94, Qty - 2

Motor Linkage, Part Number 473.63, Qty - 2

Controller, Part Number 473.11, Qty - 1

Wiring Harness, Part Number 474.59, Qty - 1

PSA Bumper, Part Number 475.43, Qty - 4

M8 U-Nut, Part Number 460.98, Qty - 8

Light, Part Number 470.15, Qty - 4

Grommet, Part Number 474.60, Qty - 1

M8-1.25 x 30 Hex Bolt, Part Number 473.18, Qty - 8

M8-1.25 x 20 Hex Bolt, Part Number 460.46, Qty - 8

M6-1.0 x 30 Socket Cap Screw, Part Number 460.95, Qty - 6

M6-1.0 x 20 Socket Head Bolt, Part Number 470.00, Qty - 8

Small Washer, Part Number 470.05, Qty - 16

Posi-Tap, Part Number 470.03, Qty - 4

7" Cable Ties, Part Number 460.99, Qty - 25

11" Cable Ties, Part Number 470.02, Qty - 2

PowerBoard – Installation Instructions

1 Install Mounting Clips - Driver's Side

Counting from the front, locate the first (1st) and last set of mounting holes on the inner sill. Use a Small Hex Bolt and a Small Washer to install a Mounting Clip on each side of each hole. Do not tighten the bolts at this time.

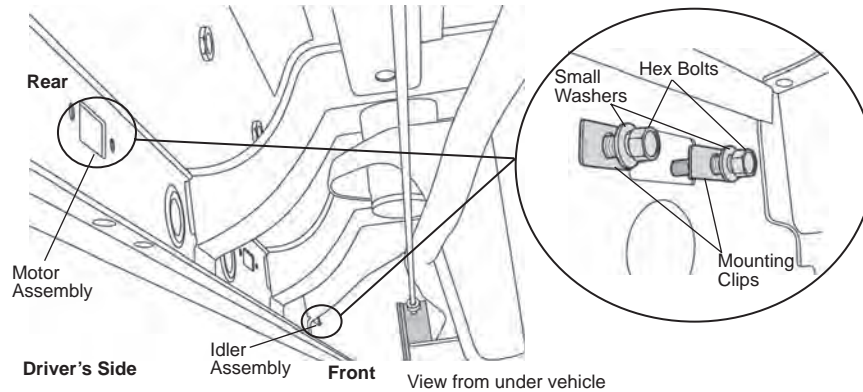

2 Install Linkage and Trim Clip - Driver's Side

Mount the Motor Linkage to the rear on the driver's side and to the front on the passenger's side. Slip the notches in the Arms under the bolts and washers installed in Step One. Tighten these bolts to 16 ft./lbs (22Nm).

Secure the bottom of the Arms with two Small Hex Bolts and Small Washers. Do not tighten the bolts yet.

NOTE If the sheet metal holes are misaligned, you may need to file off the edge of the sheet metal.

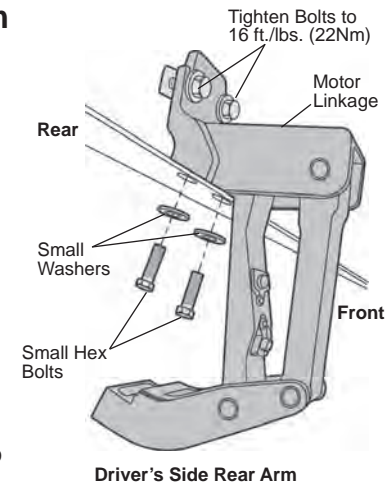

! WARNING Remove the fuse from the Wiring Harness.

3 Remove Fuse from Wiring Harness

Remove the fuse from the Wiring Harness. Failure to do so could result in severe electrical shock which could harm the installer and/or damage the vehicle.

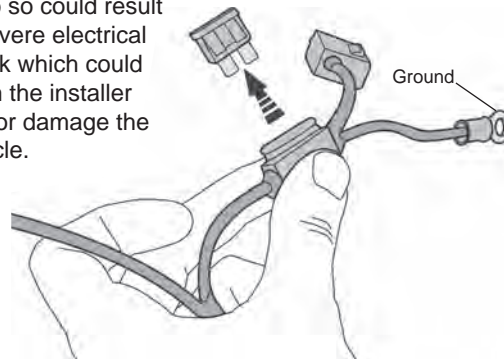

4 Install Controller and Wiring Harness

Connect the Wiring Harness to the Controller. Make sure that the locking tabs are fully engaged. Use the 11" Cable Ties to mount the Controller to the factory conduit.

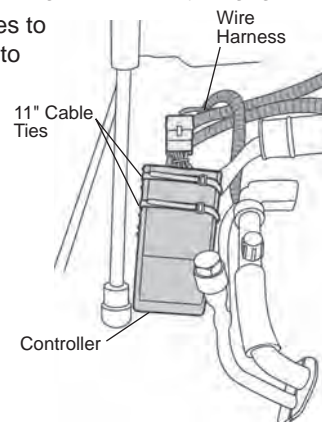

5 Connect Wiring Harness to Battery

Connect the red power lead to the positive battery terminal and the black lead to the negative terminal. Route the shorter leg of the harness to the wheel well on the passenger's side. Use the 7" Cable Ties to secure the harness.

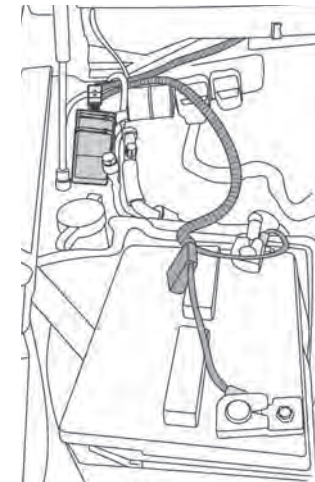

PowerBoard – Installation Instructions

6 Route Wiring Harness

Route the long leg of the Wiring Harness across the firewall through the plastic cowling and down to the driver's side wheel well. Continue along the frame. Use the 7" Cable Ties to secure the harness along the way.

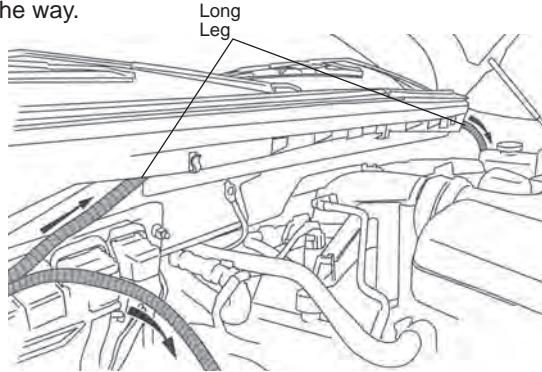

7 Remove Kick Plate and Door Sill – Passenger Side

Remove the passenger side front kick plate and door sill. Roll back the carpet to access hole in floor.

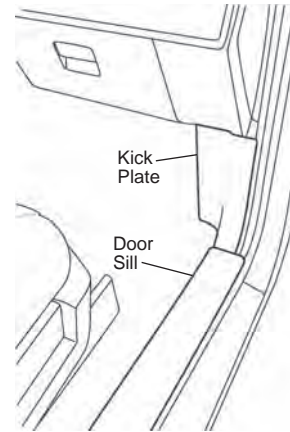

8 Install Grommet – Passenger Side

Remove the tape covering the 3/4" hole in the floor above the Idler Linkage. Install the Grommet in the hole. Thread all four (4) trigger wires from the Wiring Harness through the Grommet into the vehicle. Seal the hole with silicone sealant.

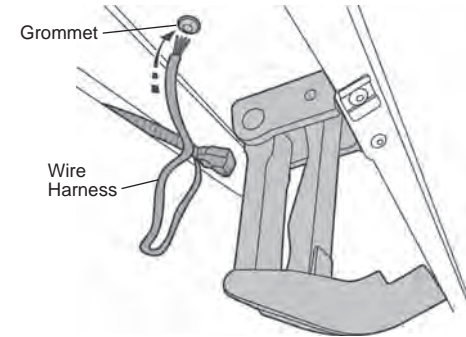

9 Connect Wires

Locate the connector under the kick plate and unplug it.

Use the Posi-Taps™ to splice the trigger wires into the like colored wires in the wire bundle.

SuperCab and Regular Cab: Connect the two (2) extra trigger wires to the same wires listed, Green connects to Green / Violet and Yellow connects to White.

Reinstall the connector.

NOTE Make sure that each Posi-Tap™ makes positive contact with the copper wire inside the insulation.

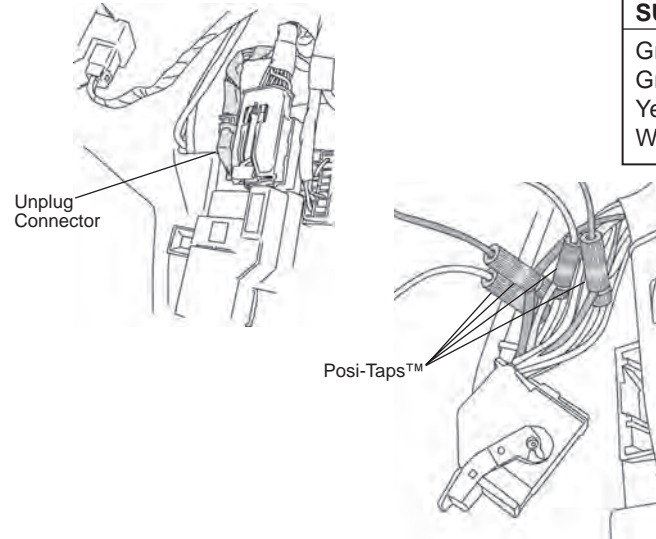

SUPERCREW	SUPERCAB	REGULAR CAB
Green / Violet Green Yellow White	Green / Violet White	Green / Violet White

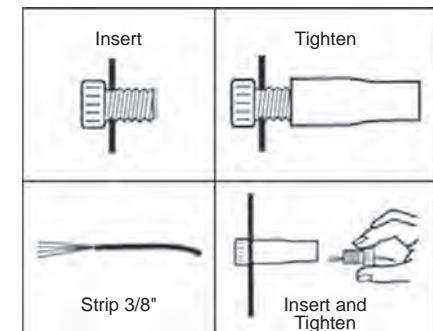

Posi-Tap™ Instructions

PowerBoard – Installation Instructions

10 Install Lights

Clean the outboard surface of the of the Linkage below the bottom mounting bolt. Peel the adhesive liner off the back of the Light and firmly press it 1/8" below the mounting bolt. Plug the light into the connector with the black and orange wires in the wire harness. Repeat with the other three lights. Secure loose wires with Cable Ties.

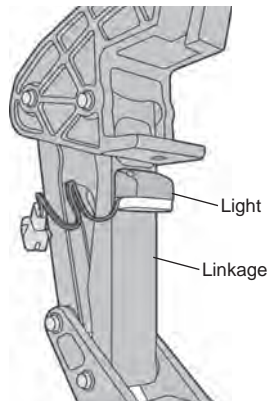

11 Install Running Boards

Orient the Running Boards on the vehicle aligning the rear of the board with the rear edge of the back doors. Mount the Steps to the linkages. Slide the mounting T-Nut into position. Install M6-1.0 x 20mm Socket Head Bolts to secure the boards. Use a 5mm Allen Wrench to tighten the bolts to 10 ft./lbs. Make sure the board moves up and down freely by hand. If it binds, loosen the linkage to body attachment bolts and adjust the linkage position until the boards move freely. Retighten the linkage to body attachment bolts.

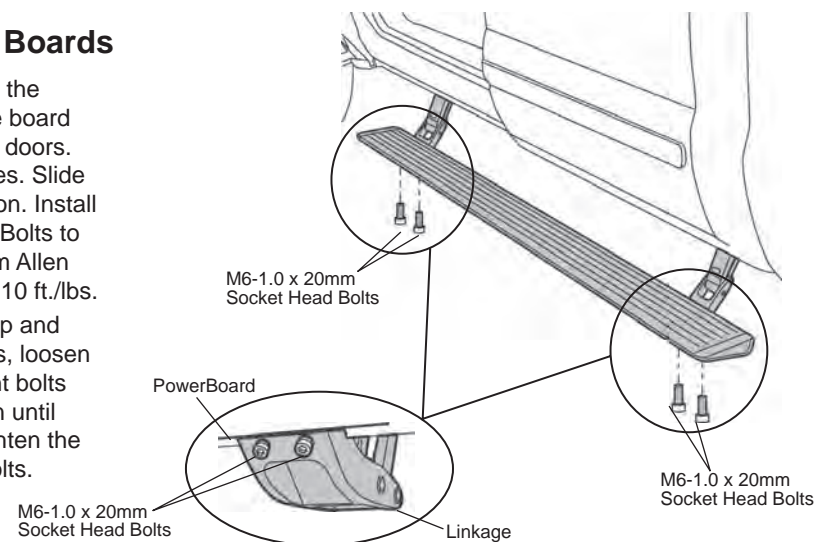

12 Install Motor

Slide Motor assembly onto drive shaft and mounting bosses of Motor Linkage assembly. Use three (3) M6-1.0 x 30mm Socket Cap Screws to secure Motor. Plug female connector into Motor. Wrap any exposed wires from the motor with electrical tape.

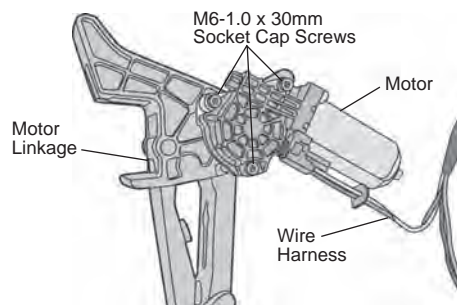

13 Reinstall Fuse

Reinstall the fuse in the harness.

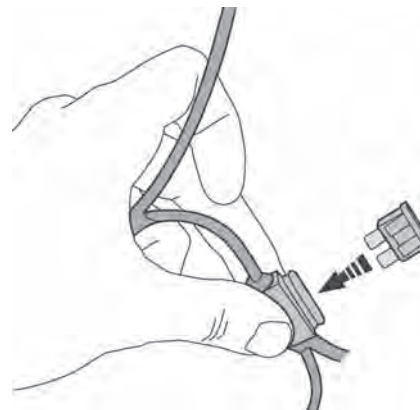

14 Test Doors

Open the doors to make sure that the PowerBoard drops into position on each side of the vehicle.

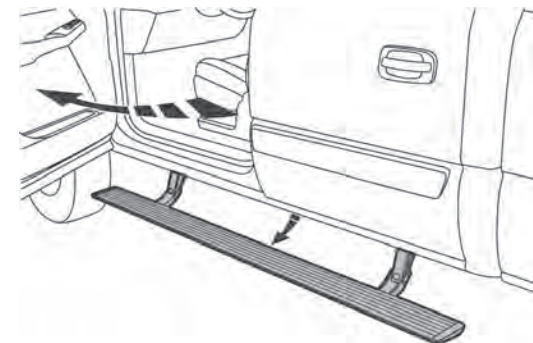

PowerBoard – Installation Instructions

15 Install PSA Bumper – Optional

Due to variations in vehicle build, the PowerBoards may contact the vehicle body when in the up position. If you would like to stop the board's travel earlier, install the supplied PSA Bumpers to the inner links or stick the bumper to the body at the location of contact.

To stop the board travel earlier, look for the area on the inner link where the Stop Bumper on the outer link would make contact if the board did not stop early (see gap in illustration).

Open the door to lower the board. Stand on the board to keep it in the down position and shut the door. Remove the fuse. Peel the backing off of the PSA Bumper and stick it to the surface on the inner link where the Stop Bumper will contact it. Do this on both idler and motor links. Reinstall the fuse and check to make sure the Stop Bumper hits the PSA Bumper when the doors are shut.

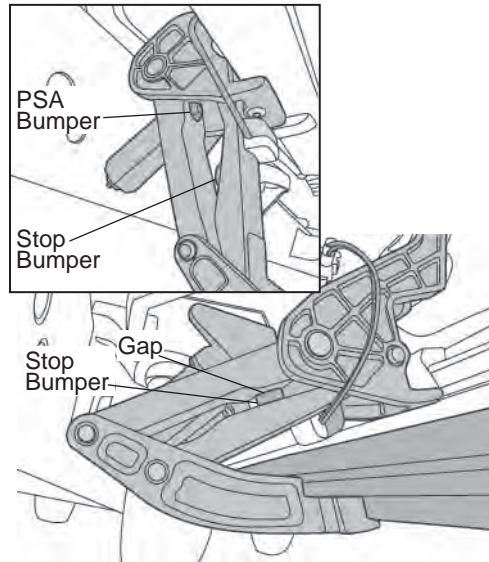

16 Reinstall Step Plates

Once you have checked that the Steps function properly, reinstall the Step Plates.

LIMITED WARRANTY

We warrant our product to be free from defects in material and workmanship, for the terms specified below, provided there has been normal use and proper maintenance. This warranty applies to the original purchaser only. All remedies under this warranty are limited to the repair or replacement of any item or items found by the factory to be defective within the time period specified. If you have a warranty claim, first you must call our factory at the number below for instructions. You must retain proof of purchase and submit a copy with any items returned for warranty work. Upon completion of warranty work, if any, we will return the repaired or replaced item or items to you freight prepaid. Damage to our products caused by accidents, fire, vandalism, negligence, misinstallation, misuse, Acts of God, or by defective parts not manufactured by us, is not covered under this warranty.

THE WARRANTY TIME PERIOD IS AS FOLLOWS FOR ALL PowerBoards MANUFACTURED BY OUR COMPANY: THREE YEARS / 36,000 MILES FROM DATE OF PURCHASE.

ANY IMPLIED WARRANTIES OF MERCHANTABILITY AND/OR FITNESS FOR A PARTICULAR PURPOSE CREATED HEREBY ARE LIMITED IN DURATION TO THE SAME DURATION AND SCOPE AS THE EXPRESS WRITTEN WARRANTY. OUR COMPANY SHALL NOT BE LIABLE FOR ANY INCIDENTAL OR CONSEQUENTIAL DAMAGE.

Some states do not allow limitations on how long an implied warranty lasts, or the exclusion or limitation of incidental or consequential damages, so the above limitations or exclusions may not apply to you. This warranty gives you specific legal rights, and you may also have other rights which vary from state to state.



For further information or request for warranty work, please contact:

Bestop Inc. Customer Service
Toll-Free: (800)845-3567
Main: (303)465-1755
E-mail: csbestop@Bestop.com
Website: www.Bestop.com