



Installation Instructions



TrekStep™





Vehicle Application

- Jeep Wrangler and Wrangler Unlimited
2007 – Current
Part Number: 75299-15

Special Note: Fits only 42911 and 43911 Bumpers

www.Bestop.com - We're here to help! Visit our web site and click on "[Ask a Question](#)". Click here for more [Jeep Accessories by Bestop](#).

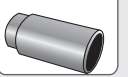
INSTALLATION TIME	SKILL LEVEL
 1/2 Hour	 1 - Easy

TOOLS				
 Ratchet	 Extension	 Socket 16 mm and 17 mm	 Allen Wrench 3/16"	 Safety Glasses



! WARNING Do not rely in any way on the components of this product to protect against injury or death in the event of an accident. Never operate the vehicle in excess of manufacturer's specifications.

WEAR SEAT BELTS AT ALL TIMES

Read and follow, precisely, all installation instructions provided when installing product. Failure to do so may result in a poor fit and could place occupants of the vehicle in a potentially dangerous situation.

TrekStep™ – Installation Instructions

Parts List and Hardware Identification

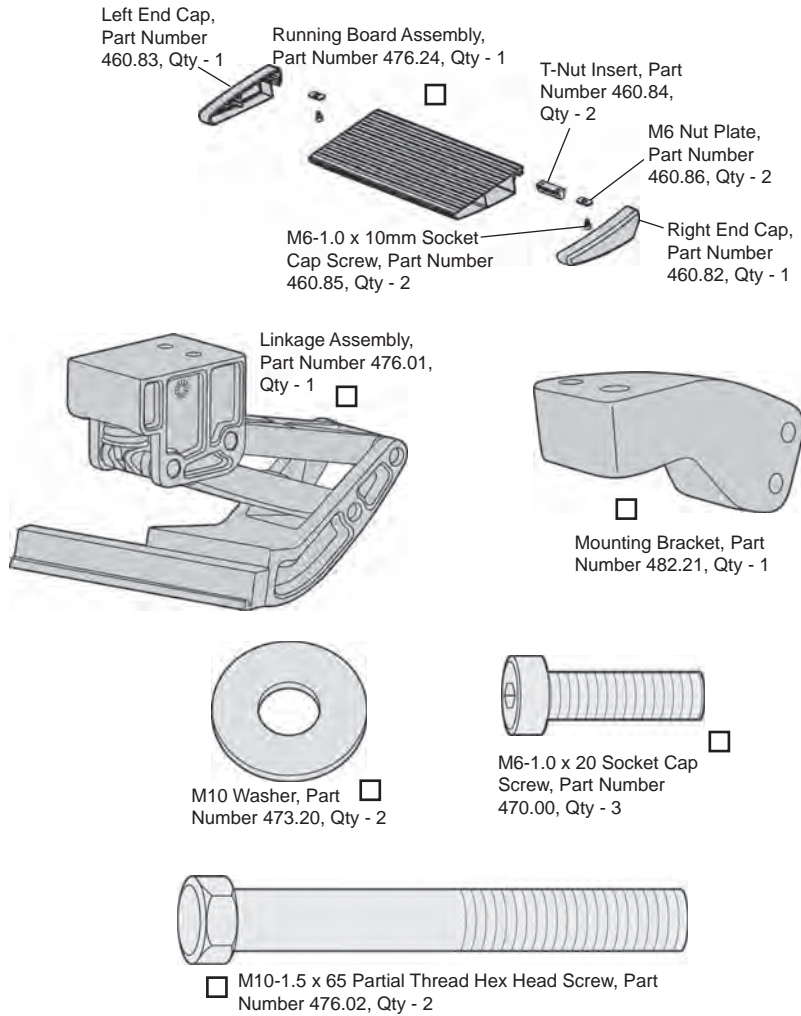

1 Locate Rear Bumper Attachment

Locate the rear bumper attachment point on the driver's side of the vehicle.

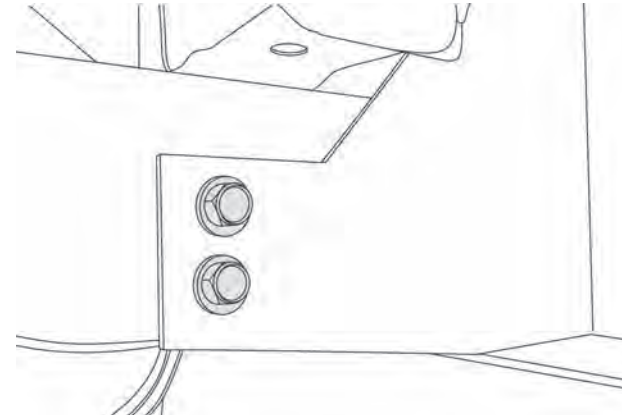

2 Remove Bumper Fasteners

Remove the bumper fasteners. Set them aside to be reused.

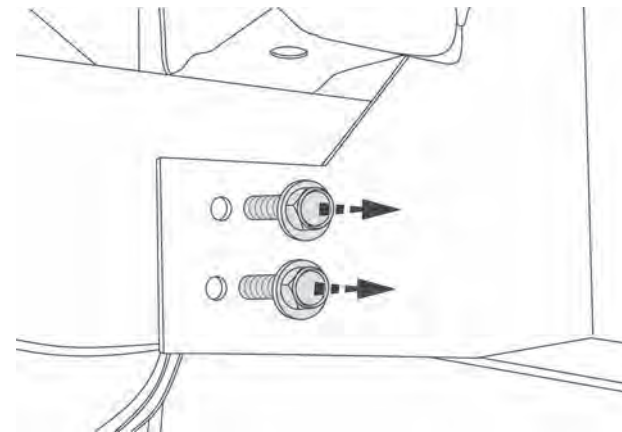

TrekStep™ – Installation Instructions

3 Assemble Linkage to Mounting Bracket

Assemble the Mounting Bracket to the Linkage.

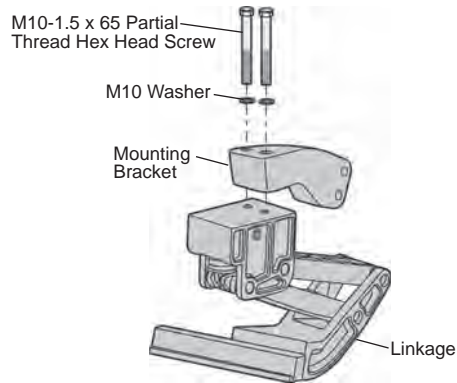

4 Install Linkage Assembly

Align the holes in the Mounting Bracket with the holes on the Bumper. Reinstall the bolts removed in Step 2.

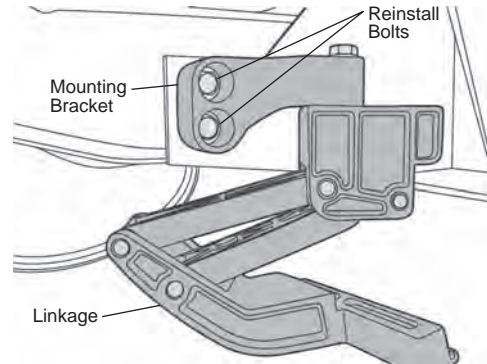

5 Install Step

Use the M6-1.0 x 20 Socket Head Cap Screws to mount the Step to the Linkage Assembly.

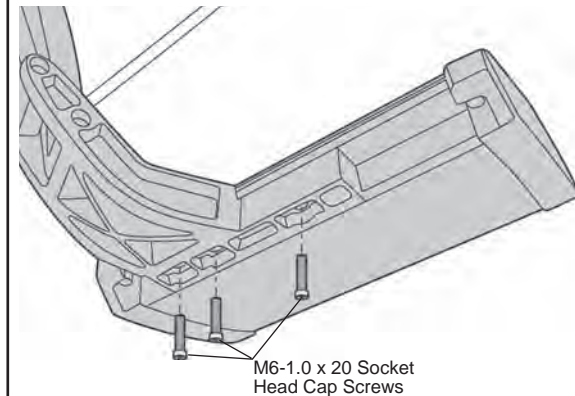

6 Adjust Step

Adjust the Step from side to side. Make sure to leave clearance for foot access to lower step. Tighten the allen head bolts.

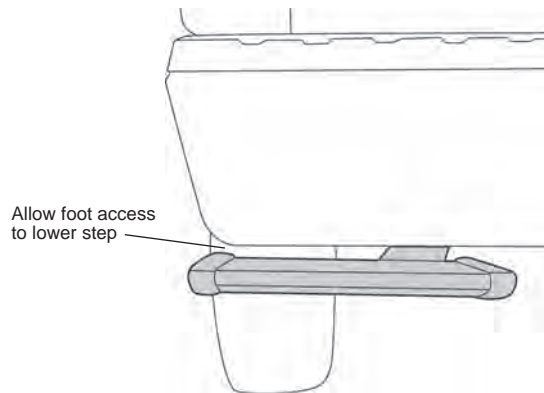

Operation

- The TrekStep™ is foot operated and deploys and retracts with a nudge of your foot.
- To deploy, press down using your left foot, on the forward outside corner of the step pad.
- To retract, gently kick the underside of the step pad.
- Max Load Capacity: 300 lbs.
- Always use appropriate hand holds when stepping up to or down from your vehicle's cargo bed.

Maintenance Tips

The step pad surface and linkage arms can be washed with mild soap and water using a soft brush or sponge to dislodge any mud, dirt or accumulated road grime. Rinse with fresh water. To prevent slipping, avoid applying waxes, lubricants or protectants like Armor All® to the step surface.

Attention!

TrekStep™ SHOULD ALWAYS BE STOWED IN THE RETRACTED POSITION WHEN DRIVING.

TrekStep™ – Installation Instructions

LIMITED WARRANTY

We warrant our product to be free from defects in material and workmanship, for the terms specified below, provided there has been normal use and proper maintenance. This warranty applies to the original purchaser only. All remedies under this warranty are limited to the repair or replacement of any item or items found by the factory to be defective within the time period specified. If you have a warranty claim, first you must call our factory at the number below for instructions. You must retain proof of purchase and submit a copy with any items returned for warranty work. Upon completion of warranty work, if any, we will return the repaired or replaced item or items to you freight prepaid. Damage to our products caused by accidents, fire, vandalism, negligence, misinstallation, misuse, Acts of God, or by defective parts not manufactured by us, is not covered under this warranty.

THE WARRANTY TIME PERIOD IS AS FOLLOWS FOR ALL TrekSteps™ MANUFACTURED BY OUR COMPANY: THREE YEARS / 36,000 MILES FROM DATE OF PURCHASE.

ANY IMPLIED WARRANTIES OF MERCHANTABILITY AND/OR FITNESS FOR A PARTICULAR PURPOSE CREATED HEREBY ARE LIMITED IN DURATION TO THE SAME DURATION AND SCOPE AS THE EXPRESS WRITTEN WARRANTY. OUR COMPANY SHALL NOT BE LIABLE FOR ANY INCIDENTAL OR CONSEQUENTIAL DAMAGE.

Some states do not allow limitations on how long an implied warranty lasts, or the exclusion or limitation of incidental or consequential damages, so the above limitations or exclusions may not apply to you. This warranty gives you specific legal rights, and you may also have other rights which vary from state to state.



For further information or request for warranty work, please contact:
Bestop Inc. Customer Service
Toll-Free: (800)845-3567
Main: (303)465-1755
E-mail: csbestop@Bestop.com
Website: www.Bestop.com