

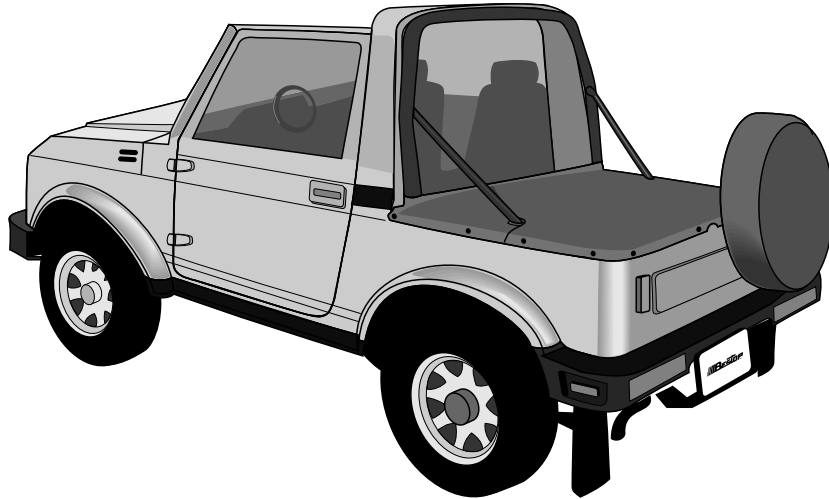

Bestop



Installation Instructions and Owner's Manual

Duster

Model: Suzuki Samurai

Part Number 90006

Note: Please read this manual thoroughly before beginning the installation. After completing installation, keep this manual for future reference.

WARNING:

This product is designed to enhance the appearance of the vehicle and to shield the occupants from ordinary weather conditions. Do not rely in any way on the components of this product to contain occupants within the vehicle, or to protect against injury or death in the event of an accident. This product will not protect the occupants from falling objects. Never operate vehicle in excess of manufacturer's specifications.

WEAR SEAT BELTS AT ALL TIMES.

Read and follow, precisely, all installation instructions provided when installing this product. Failure to do so may result in a poor fit and could place occupants of the vehicle in a potentially dangerous situation.

Before You Install

You may notice some wrinkling in the fabric of your Duster when you first remove it from its shipping container. **Don't Panic.** It is normal for the tonneau to do this when stored in the shipping container. The wrinkles and indentations will disappear after 48-72 hours of exposure to sunlight.

Note: You should install your Duster in temperatures of 70° F (21° C) or warmer. The fabric will contract in cooler temperatures, making proper installation difficult.

Note: The original hardware is required for the proper installation of this product.

You are now ready to begin the installation process.

Installation: Getting Started

Make sure that the temperature where you are going to install your Duster is at least 70° F (21° C). If it is cooler than this outside, we suggest that you install your Duster in a heated garage. Do not try to install your Duster in temperatures less than 70° F (21° C) because proper installation will not be possible.

Tools You Will Need

- A soft cloth
- Scissors
- 50/50 Alcohol/Water Solution
- Phillips screwdriver

Carefully remove the parts from the shipping container.

Parts List and Hardware Identification

Check off each item

| | |
|-------------------------------|---------|
| Tonneau Fabric Assembly | Qty - 1 |
| Adhesive Hook Strip, 70" x 1" | Qty - 1 |

Installing the Duster

Note: If you have a top on your vehicle, you will need to remove it and use a phillips screwdriver to remove the bow assembly.

Step One

Remove or fold down the back seat.

Step Two

The adhesive Hook Strip attaches to the Loop portion sewn into the Duster and provides a quick and secure fastener.

Use a 50/50 solution of alcohol and water to clean the locations for the adhesive Hook Strip (see Figures 1 and 4). Be sure to remove all dirt, silicone sealants, wax, and any other substances which might prevent the adhesive from sticking to the paint.

Note: Do not attempt to apply the adhesive hook in temperatures of less than 60° F. The adhesive backing will fully set within 72 hours of application. You may install the Duster after about one hour, but you should avoid unnecessary fastening and unfastening of the cover for 72 hours.

Step Three

Cut the adhesive hook into:

- 2 pieces - 6 inches long
- 1 piece - 2 inches long
- 2 pieces - 10 inches long
- 4 pieces - 9 inches long

Do not remove the plastic backing until you are ready to install the hook.

Step Four

The 9" x 1" Adhesive Hook Strips and the 10" x 1" Adhesive Hook Strips will be placed on the sides of the vehicle (see Figure 1). Once you have cleaned the area with the Alcohol/Water Solution, locate the hook strips between the snaps on both sides of the vehicle. The 10" strips will be located between the two front screws and the 9" strips will be placed between the second and third screws, and the third and fourth screws (see Figure 1). Remove the plastic backing and install the Adhesive Hook Strips with firm, direct pressure to insure maximum adhesion.

Figure 1

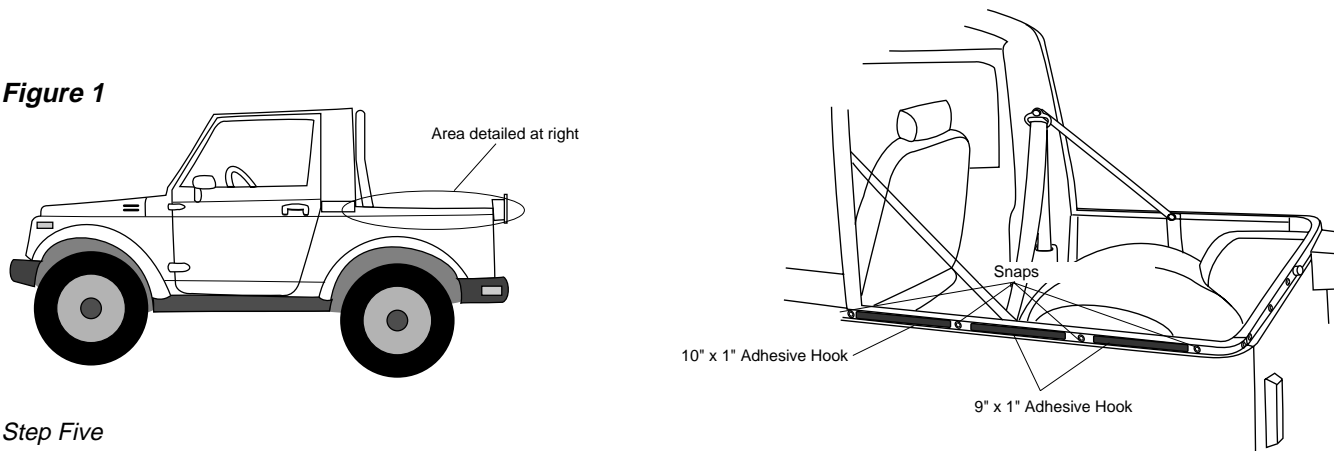

Step Five

Unfold the Duster and drape it over the rear of the vehicle with the web straps toward the front of the vehicle.

Step Six

Snap the two rear corner snaps on the passenger side of the vehicle, then snap the two rear corner snaps on the driver's side. Snap the snaps on both sides of the vehicle, starting at the back and alternating from side to side.

Step Seven

Locate the two web straps sewn to the front of the cover (see Figure 2). Wrap the straps around the sport bars and thread them through the buckles (see Figure 2 detail).

Figure 2

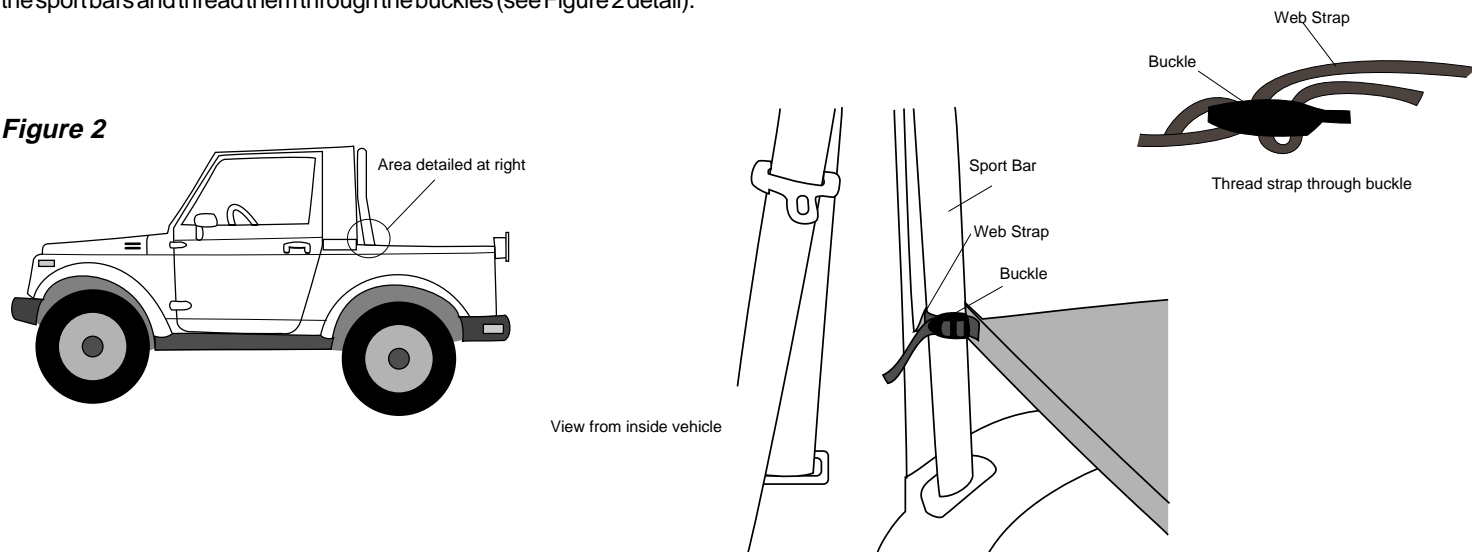

Step Eight

Use the loop strip sewn to the rear of the Duster as a guide to place the two 6 inch pieces and the one 2 inch piece of Adhesive Hook Strip along the rear of the vehicle (see Figure 3). The 6 inch pieces will be placed on each side of the Spare Tire Carrier and the 2 inch piece will be placed to the outside of the spare tire bumper on the driver's side. Remove the plastic backing and install the strips. Use firm, direct pressure to insure maximum adhesion.

Figure 3

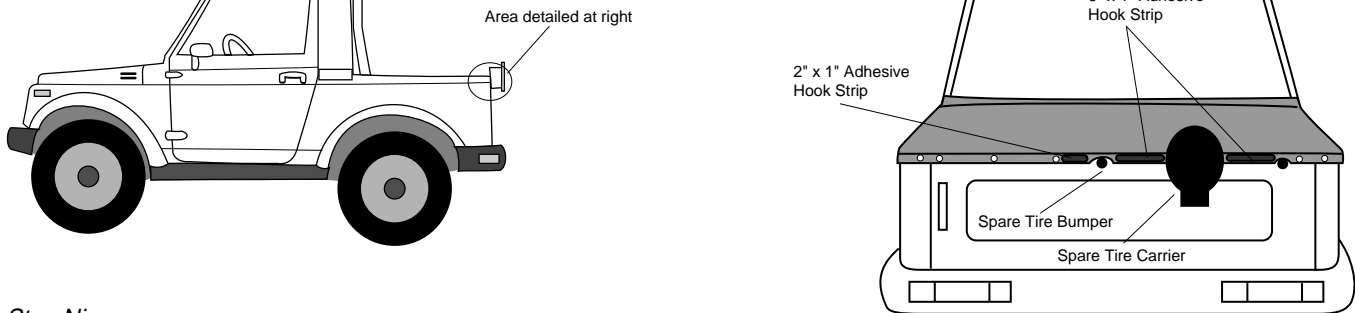

Step Nine

Fasten the Lift-A-Dots on the cover to the studs on the rear of the vehicle. Fasten the loop strips on the Duster to the hook strips you have installed around the vehicle. Wrap the flaps around the base of the Sport Bar supports and fasten the hook and loop strips to each other.

Care and Maintenance of your Bestop Duster

Your Duster is made of the finest materials available. To keep it looking new and for the maximum possible wear, it will need periodic cleaning and maintenance.

Washing: The Duster fabric should be washed often using soap, warm water and a soft bristle brush. Rinse with clear water to remove all traces of soap.

Water: Seeping through at the seams may be stopped by applying 3-M Scotchgard® on the inside of the seams. Rips in the fabric may be repaired with Bondex® iron on patches. Iron the patches to the Inside of the top, carefully following the Bondex® instructions.

Snaps: Keep snaps cleaned and lubricated with silicone to help prevent snaps from sticking to the studs. If a snap does become stuck to a stud, use a screwdriver and GENTLY pry apart to prevent permanent damage to the snap or the top fabric.

LIMITED WARRANTY

We warrant our product to be free from defects in material and workmanship, for the terms specified below, provided there has been normal use and proper maintenance. This warranty applies to the original purchaser only. All remedies under this warranty are limited to the repair or replacement of any item or items found by the factory to be defective within the time period specified.

If you have a warranty claim, first you must call our factory at the number below for instructions. You must retain proof of purchase and submit a copy with any items returned for warranty work. Upon completion of warranty work, if any, we will return the repaired or replaced item or items to you freight prepaid. Damage to our products caused by accidents, fire, vandalism, negligence, misinstallation, misuse, Acts of God, or by defective parts not manufactured by us, is not covered under this warranty.

THE WARRANTY TIME PERIOD IS AS FOLLOWS: ALL "SOFT GOODS" MANUFACTURED BY OUR COMPANY (USING PRIMARILY VINYL, PLASTICS, AND/OR FOAM): ONE YEAR FROM DATE OF PURCHASE.

ANY IMPLIED WARRANTIES OF MERCHANTABILITY AND/OR FITNESS FOR A PARTICULAR PURPOSE CREATED HEREBY ARE LIMITED IN DURATION TO THE SAME DURATION AND SCOPE AS THE EXPRESS WRITTEN WARRANTY. OUR COMPANY SHALL NOT BE LIABLE FOR ANY INCIDENTAL OR CONSEQUENTIAL DAMAGE.

Some states do not allow limitations on how long an implied warranty lasts, or the exclusion or limitation of incidental or consequential damages, so the above limitations or exclusions may not apply to you.

This warranty gives you specific legal rights, and you may also have other rights which vary from state to state.

For further information or request for warranty work, please contact:

Bestop Inc.
Customer Service
(800)346-3910
(303)465-1755