









Installation Instructions Duster™ Deck Cover

Vehicle Application

- Jeep Wrangler TJ Unlimited
with Factory Hard Top
2004 – 2006
Part Number: 90024

www.Bestop.com - We're here to help! Visit our web site and click on "[Ask a Question](#)". Click here for more [Jeep Accessories by Bestop](#).

INSTALLATION TIME	SKILL LEVEL
 1 Hour	 2 - Moderately Easy

TOOLS			
 Phillips Screwdriver #2	 Power Drill 1/8"	 Center Punch	 Safety Glasses



Installation Tips

Before you begin installing this assembly, read all instructions thoroughly.

For a smooth fit:

For ease in installation, the product should be installed at temperatures above 72° F. Below this temperature, the fabric may contract an inch or more, making it difficult to fit to the vehicle. It is normal for fabric to contract and wrinkle when stored in the shipping carton. Within a few days after the installation, the fabric will relax and the wrinkles will disappear.



CAUTION

Safety glasses should be worn at all times while installing this product.



WARNING

This product is designed primarily to enhance the appearance of the vehicle and to shield the occupants from ordinary weather conditions. Do not rely in any way on the components of this product to contain occupants within the vehicle, or to protect against injury or death in the event of an accident. This product will not protect the occupants from falling objects. Never operate the vehicle in excess of manufacturer's specifications.

WEAR SEAT BELTS AT ALL TIMES

Read and follow, precisely, all installation instructions provided when installing product. Failure to do so may result in a poor fit and could place occupants of the vehicle in a potentially dangerous situation.

Parts List and Hardware Identification

Duster

Qty - 1

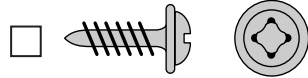

#8 x 1/2" Pan Head Washer Screw - Black, Qty - 4, Part Number 200.48

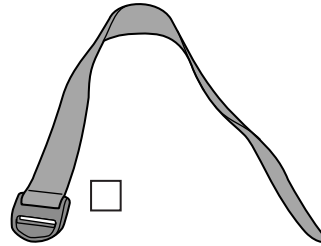

Web Buckle Strap, Qty - 1, Part Number 407.34

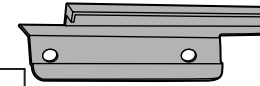

Tailgate Retainer Mount, Left, Qty - 1, Part Number 311.85

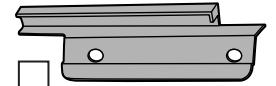

Tailgate Retainer Mount, Right, Qty - 1, Part Number 311.86

Tailgate Bar, Qty - 1, Part Number 288.76

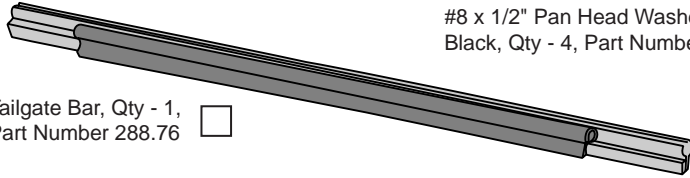

Installation

Step One

INSTALL TAILGATE RETAINER MOUNTS

Locate the left and right Tailgate Retainer Mounts. Place the mounts flush with the edge of the tailgate opening. Install the Tailgate Retainer Mounts with two #8 x 1/2" Pan Head Washer Screws for each mount.

If your vehicle does not have holes at this location, align the Tailgate Retainer Mounts flush with the edge of the tailgate opening. Then mark the locations of the holes in the mounts, center punch and drill a 1/8" hole at the marked locations. Install the mounts with two #8 x 1/2" Pan Head Washer Screws for each mount.

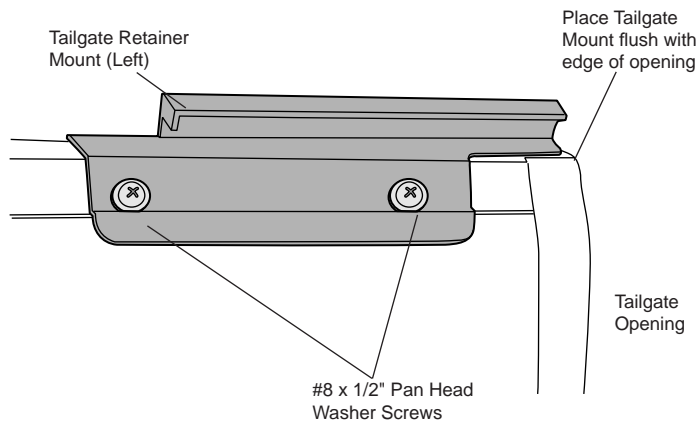

Caution

Safety glasses should be worn at all times while installing this product.

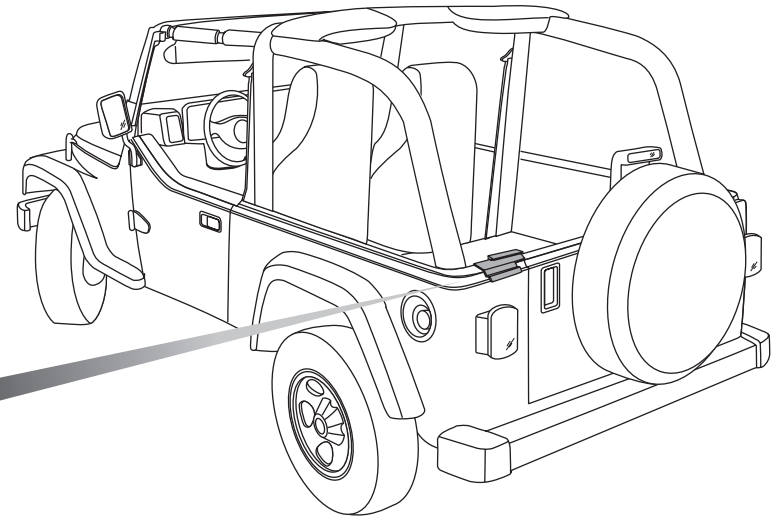

Note: This product is designed for a "Custom Fit". Be patient during the installation, it fits tight!

Step Two

SECURE REAR SEAT

Locate the Web Buckle Strap in the parts kit. Thread the web end of the strap through the footman loop closest to the rear of the seat on the Driver's side. Fold the back of the seat down and thread the web through the bar on the seat back. Thread the end of the strap through the buckle and pull it tight. Tightening the strap securely will keep the seat from banging when the vehicle is moving.

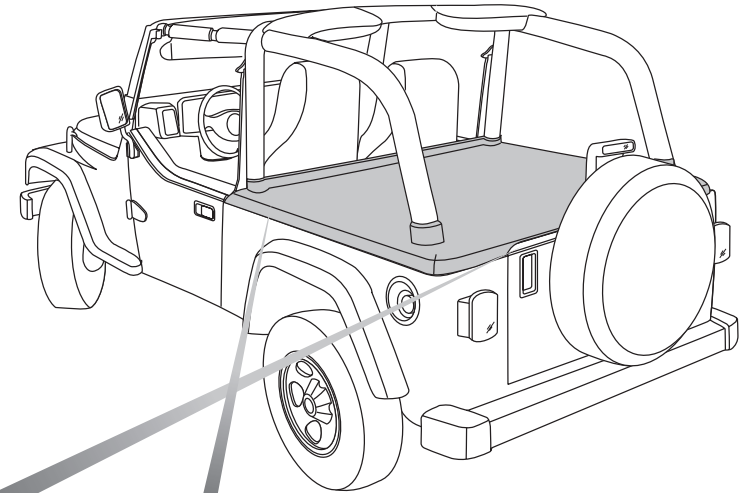
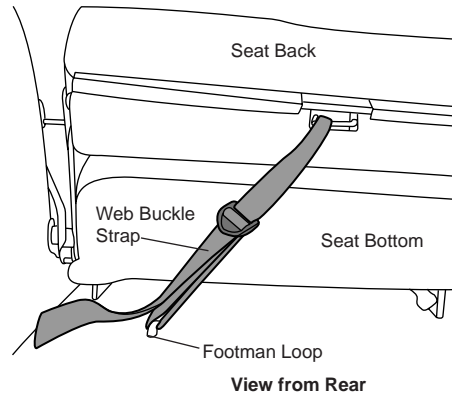

Step Three

INSTALL TAILGATE BAR

From the back of the vehicle, hold the Duster with the backing side toward you. Orient the Tailgate Bar with the rubber bulb facing down, in order to form a seal with the top of the tailgate. Slide the groove in the Tailgate Bar onto the tube inside the rear of the Duster. Roll the Tailgate Bar into the top of the Tailgate Retainer Mounts.

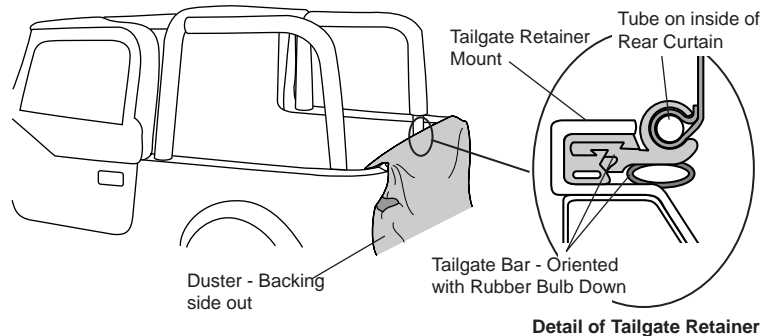

Step Four

SECURE WEB STRAPS

Drape the fabric forward over the rear of the vehicle and locate the web straps, with buckles attached, on the front of the Duster. Wrap the straps around the front sport bars and thread the ends loosely through the buckles. Do not pull the straps tight at this time.

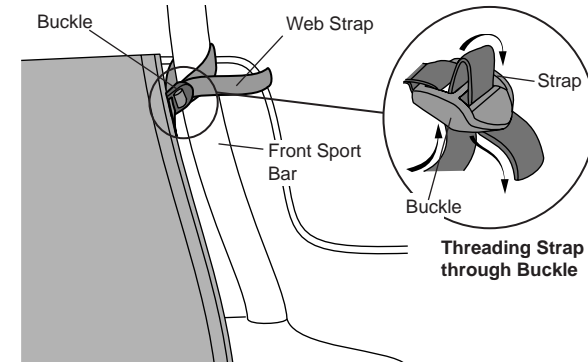

Step Five

SECURE PLASTIC STRIPS

Locate the plastic strip sewn to the Duster along each side of the vehicle. Start at one end on each side and roll the plastic strip into the Side Retainers.

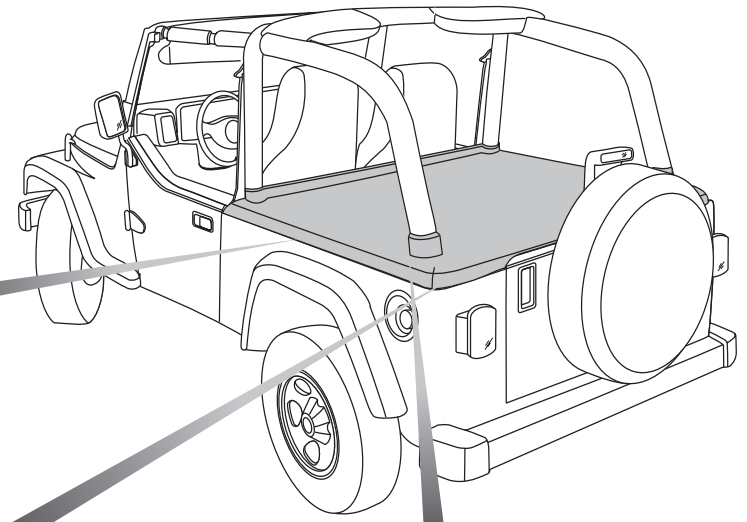
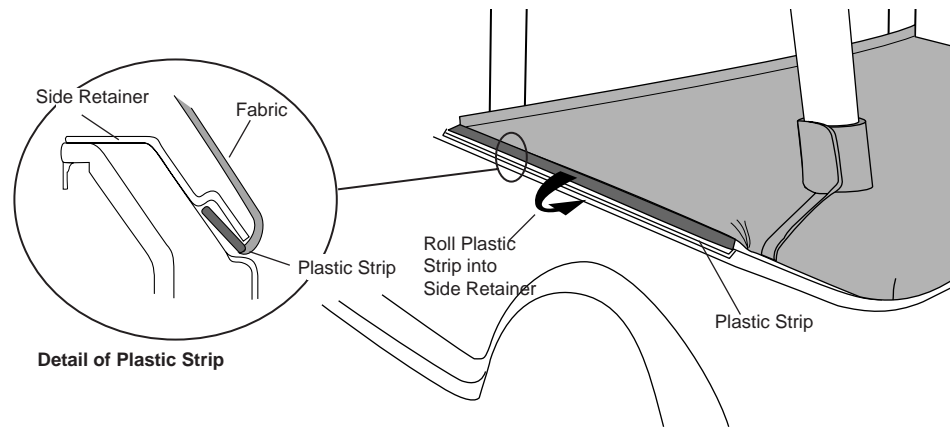

Step Six

SECURE REAR CORNERS

Roll the plastic strips, sewn into the rear corners of the Duster into the Corner Retainers. Slide the corner plastic strip toward the front of the vehicle and make sure that the plastic strip fits up into the retainer so that the collar fits properly.

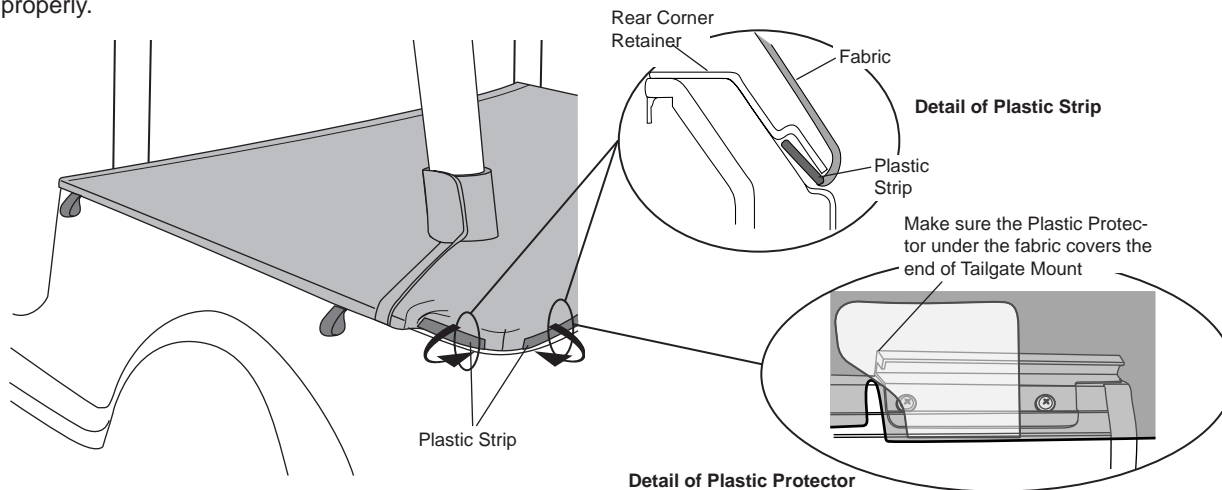

Note: The Plastic Protector sewn into the fabric must be located over the Tailgate Retainer Mounts.

Step Seven

SECURE COLLARS

Tuck the seat belt assemblies into the rear sport bar collars and close the rear sport bar collars by pulling firmly on the fabric and fastening the Hook and Loop Strips to each other.

Tighten the straps on the front of the Duster.

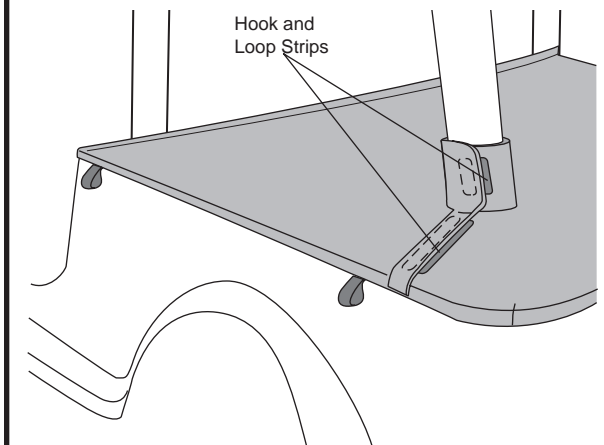

To Remove Duster

When removing the Duster, use the loops sewn to the fabric to release the plastic strips. Pull gently down, then straight out to release the plastic strip from the retainers.

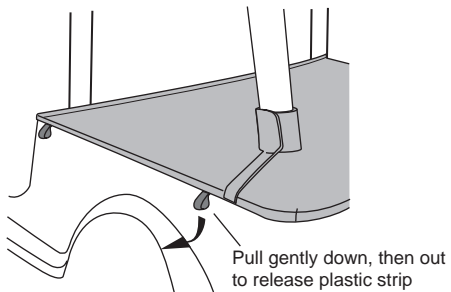

If You Have a New Windjammer on Your Vehicle Optional Installation

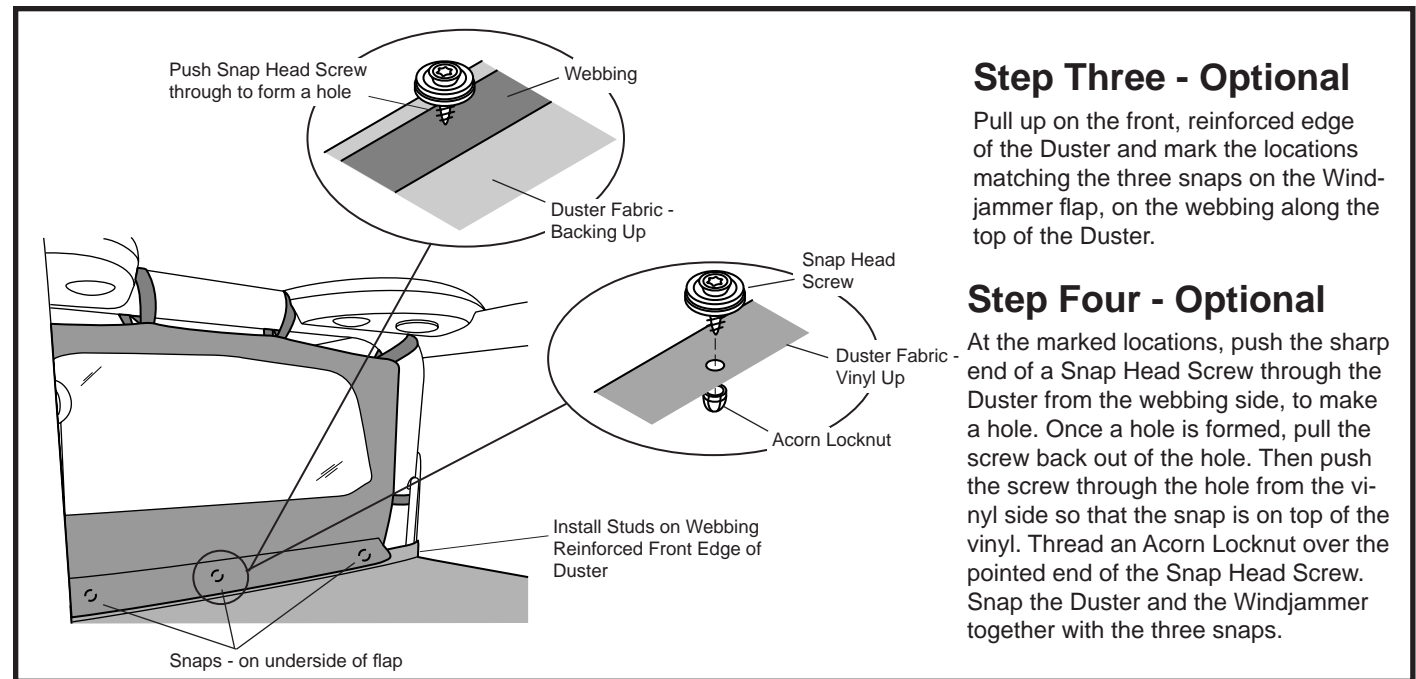
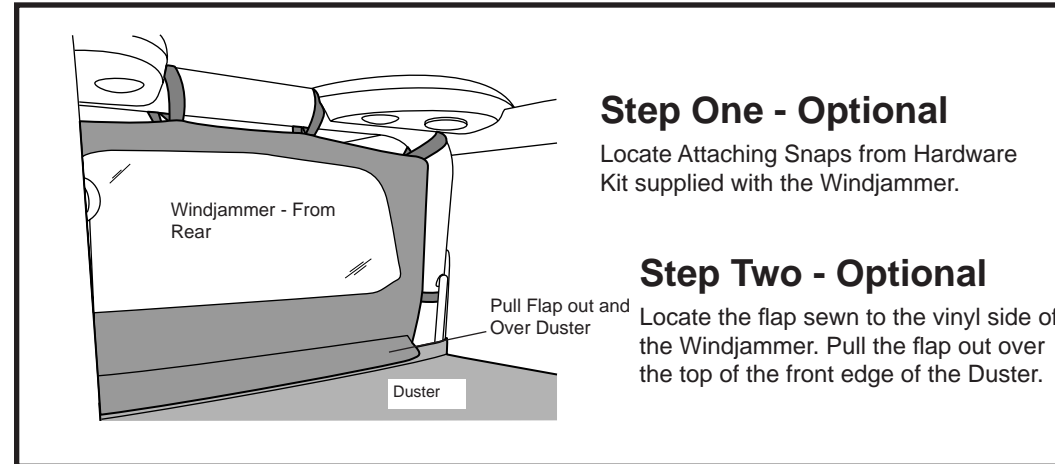

Care and Maintenance of your Bestop Product

Your Bestop product is made of the finest materials available. To keep it looking new and for the maximum possible wear, it will need periodic cleaning and maintenance.

Washing: The fabric should be washed often using soap, warm water and a soft bristle brush. Rinse with clear water to remove all traces of soap or use Bestop-recommended Bestop Cleaner and Bestop Protectant. Bestop Cleaner and Bestop Protectant are specially formulated to provide a total cleaning and protection system. Bestop Cleaner will not harm vehicle finish, is biodegradable and environmentally friendly. Bestop Protectant protects against UV-fading, cracking and hardening.

Water: Seeping through at the seams may be stopped by applying 3-M Scotchgard® on the inside of the seams. Rips in the fabric may be repaired with Bondex® iron on patches. Iron the patches to the Inside of the top, carefully following the Bondex® instructions.

Snaps: Keep snaps cleaned and lubricated with silicone to help prevent snaps from sticking to the studs. If a snap does become stuck to a stud, use a screwdriver and GENTLY pry apart to prevent permanent damage to the snap or the top fabric.

LIMITED WARRANTY

We warrant our product to be free from defects in material and workmanship, for the terms specified below, provided there has been normal use and proper maintenance. This warranty applies to the original purchaser only. All remedies under this warranty are limited to the repair or replacement of any item or items found by the factory to be defective within the time period specified. If you have a warranty claim, first you must call our factory at the number below for instructions. You must retain proof of purchase and submit a copy with any items returned for warranty work. Upon completion of warranty work, if any, we will return the repaired or replaced item or items to you freight prepaid. Damage to our products caused by accidents, fire, vandalism, negligence, misinstallation, misuse, Acts of God, or by defective parts not manufactured by us, is not covered under this warranty.

THE WARRANTY TIME PERIOD IS AS FOLLOWS FOR REPLACE-A-TOP™, SAILCLOTH REPLACE-A-TOP™, SUPERTOP®, SUPERTOP® REPLACEMENT SKINS, SUNRIDER®, AND TIGERTOP®: TWO YEARS FROM DATE OF PURCHASE.

THE WARRANTY TIME PERIOD IS AS FOLLOWS FOR ALL OTHER "SOFT GOODS" MANUFACTURED BY OUR COMPANY (USING PRIMARILY VINYL, PLASTICS, AND/OR FOAM): ONE YEAR FROM DATE OF PURCHASE.

THE WARRANTY TIME PERIOD IS AS FOLLOWS FOR ALL OTHER "HARD GOODS" MANUFACTURED BY OUR COMPANY (USING PRIMARILY METALS, PLASTICS, AND/OR FIBERGLASS): ONE YEAR FROM DATE OF PURCHASE.

ANY IMPLIED WARRANTIES OF MERCHANTABILITY AND/OR FITNESS FOR A PARTICULAR PURPOSE CREATED HEREBY ARE LIMITED IN DURATION TO THE SAME DURATION AND SCOPE AS THE EXPRESS WRITTEN WARRANTY. OUR COMPANY SHALL NOT BE LIABLE FOR ANY INCIDENTAL OR CONSEQUENTIAL DAMAGE.

Some states do not allow limitations on how long an implied warranty lasts, or the exclusion or limitation of incidental or consequential damages, so the above limitations or exclusions may not apply to you. This warranty gives you specific legal rights, and you may also have other rights which vary from state to state.



For further information or request for warranty work, please contact:
Bestop Inc., Customer Service
Toll-Free: (800)845-3567
Main: (303)465-1755
E-mail: csbestop@Bestop.com
Website: www.Bestop.com

Note: All or a portion of this product may be made in China.