

banks

with Installation Instructions
Owner's Manual

**Banks
High-Ram®
Intake**

Compatible with Optional Banks Boost Tube

**1998 to 2002 Dodge 5.9L Cummins (24-valve)
ISB Pickup Trucks**

USE WITH SYSTEM P/N 42721 & 42722

Gale Banks Engineering
546 Duggan Avenue • Azusa, CA 91702
(626) 969-9600 • Fax (626) 334-1743

Product Information & Sales: (888) 635-4565

bankspower.com

banks

General Installation Practices

Dear Customer,

If you have any questions concerning the installation of your Banks High-Ram Intake & Boost Tube, please call our Technical Service Hotline at (888) 839-2700 between 7:00 am and 5:00 pm (PT). If you have any questions relating to shipping or billing, please contact our Customer Service Department at (888) 839-5600.

Thank you.

1. For ease of installation of your Banks High-Ram Intake and optional Banks Boost Tube, Please familiarize yourself with the procedure by reading the entire manual before starting work.
2. Throughout this manual, the left side of the vehicle refers to the driver's side, and the right side to the passenger's side.
3. Disconnect the negative (ground) cable from the battery (or batteries, if there are two) before beginning work.
4. Route and tie wires and hoses a minimum of 6" away from exhaust heat, moving parts and sharp edges. Clearance of 8" or more is recommended where possible.
4. The installation should be performed at time when the vehicle has been allowed to completely cool. This installation requires the installer to work near surfaces that may remain hot after the vehicle has been run. Failure to allow the vehicle to cool may result in personal injury.
5. When raising the vehicle, support it on properly weight-rated safety stands, ramps or a commercial hoist.

Follow the manufacturer's safety precautions. Take care to balance the vehicle to prevent it from slipping or falling. When using ramps, be sure the front wheels are centered squarely on the topsides. When raising the front of the vehicle, put the transmission in park (automatic) or reverse (manual), set the parking brake, and block the rear wheels. When raising the back of the vehicle, be sure the vehicle is on level ground and the front wheels are blocked securely.

CAUTION! Do not use floor jacks to support the vehicle while working under it. Do not raise the vehicle onto concrete blocks, masonry or any other item not intended specifically for this use.

6. During installation, keep the work area clean. Do not allow anything to be dropped into intake, exhaust, or lubrication system components while performing the installation, as foreign objects will cause immediate engine damage upon start-up.

Tools Required:

- Drive ratchet
- Ratchet extensions
- Open-end Wrenches
- Inch and metric deep sockets
- Torx & Allen bits
- Flat blade screwdriver

Highly recommended tools:

- Torque wrench
- Gasket scraper

STOCK INTAKE ELBOW AND BOOST TUBE REMOVAL

1. Disconnect the negative battery cables from both batteries
2. Loosen the clamps that hold the rubber hose at the inlet of the stock intake elbow and slide the hose free of the intake elbow inlet.
3. Remove the bolt that holds the engine oil dipstick to the intake elbow. Save the bolt for re-use. Gently push and move the dipstick and its holder to the rear of the engine compartment to gain access to the engine.
4. Remove the electric heater wire harness from the stock intake elbow by pulling the plastic pin out. Remove the wire harness brackets that are mounted on the intake elbow by removing the nut and washer.
5. Unbolt and remove the 4 bolts at the base of the stock intake elbow. Remove the stock intake elbow from the vehicle.
6. Disconnect the wires on the electric heater block at the intake

manifold, then remove the heater block. Save the fasteners for re-use.

CAUTION: Cover the opening in the intake manifold with a clean rag to prevent foreign objects from entering the engine.

7. Being careful not to scratch or gouge the mating surfaces of the parts, completely remove the stock gaskets from both sides of the heater element block and intake manifold, using a gasket scraper as needed. Clean and dry all sealing surfaces thoroughly.

If Not Installing optional Banks Boost Tube, skip to step 10.

8. Remove the driver side boost tube, hoses and hose clamps. Retain the factory hose and hose clamps at the inlet of the factory driver side boost tube for reuse with Banks Boost Tube. The boost tube is the charge air ducting that routes air from the Charge Air Cooler (CAC) to the intake manifold.

Figure 2. High-Ram stud installation.

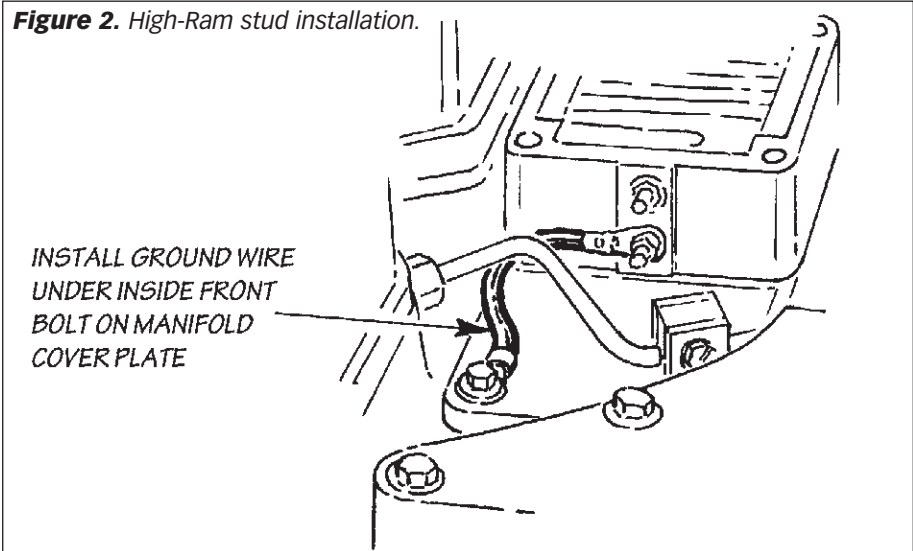

BANKS HIGH-RAM INTAKE AND BOOST TUBE INSTALLATION

9. Install Banks driver side boost tube. The driver side tubes use a 3.5 inch diameter hump hose and Spring loaded clamps at the connection to the Banks High-Ram and re-use the factory hose and clamps at the CAC. Keep the hose clamps loose until the High Ram is installed. Cover the opening of the boost tube to prevent foreign objects from entering the boost tube during the installation.

*Note: Before slipping any boost tubes and the corresponding hoses, into position, ensure that all connection ends are clean and free of any oil residue and contaminates. Clean all connection points with a **non-oil based solvent** such as Acetone, Mineral Spirits, Denatured Alcohol or Lacquer Thinner. Read and follow the manufactures operation instruction for non-oil based solvent cleaner.*

10. Remove the rag that was used to cover the intake. Reinstall the electric heater block onto the intake manifold with one of the supplied gaskets. Reattach the electrical connections to the heater element.

11. Loosen the nut on the ground strap for the intake heater element and rotate the cable around so that the ring terminal can be reinstalled under the head of the intake bolt.

Important: do not allow the terminal on the element end of the ground cable to come in contact with the upper heater lug or with the injector line. Retighten the retaining nut and reinstall the front intake manifold bolt through the ring terminal. See Figure 2.

13. CAUTION: The High Ram studs have different threads on each end. Make sure the M8 ends go into the engine intake manifold. The shorter studs are placed inboard closest to the valve cover. Apply the

Figure 3. High-Ram stud installation.

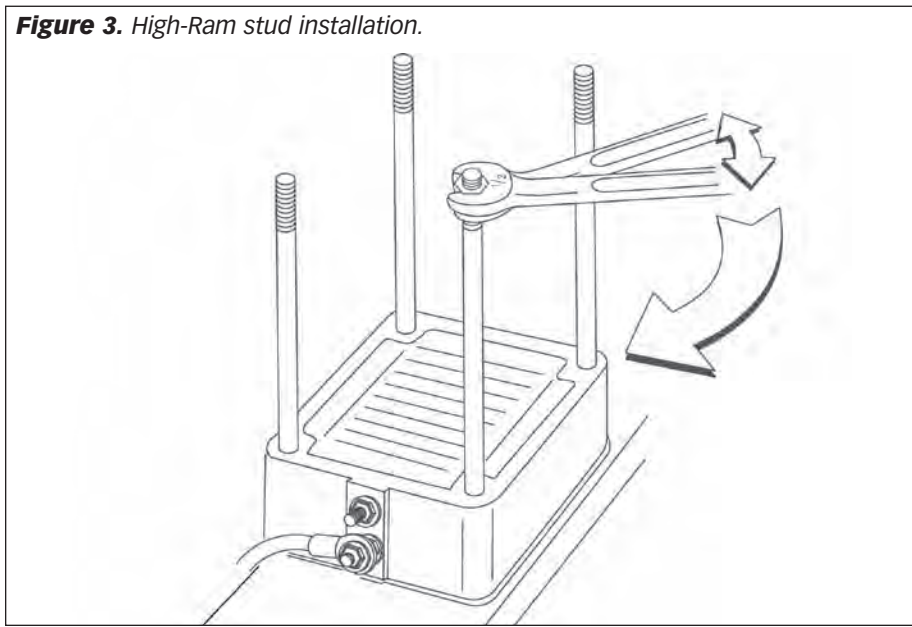

supplied thread locking compound to the M8 threaded end of the studs. Hand tighten the studs to the intake manifold.

14. Using the two $\frac{5}{16}$ "-24 hex nuts supplied, tighten the studs into the intake by threading both nuts onto the stud, then tighten the nuts against each other with two $\frac{1}{2}$ " open end wrenches. Tighten and torque the stud to 3-5 ft-lbs by turning the top nut. Remove the nuts from the stud by using the two open end wrenches to loosen the nuts in relation to each other. Repeat the process for each stud. The process is shown in **Figure 3**.

16. Slide the supplied intake gasket over the four studs, then slide the High-Ram over the studs.

17. Install the supplied Stat-O-Seal washers on the two driver side (longer) studs. Driver side studs are longer than passenger side studs. The washers should be installed in a twisting motion to prevent tearing their sealing element. Install the supplied $\frac{5}{16}$ " flat washer on all studs,

then fasten with the supplied $\frac{5}{16}$ -24 nylock nuts. The nuts should be tightened to 12 ft-lbs (144 in-lbs). An exploded view of the High-Ram assembly is shown in **Figure 4**.

18. For 2001 models, a spacer bracket is provided. Mount it to the High-Ram casting using the original factory bolt. Fasten the dipstick tube bracket to the spacer bracket using the $\frac{5}{16}$ " nylock nut and bolt.

For all other models, gently bend the engine oil dipstick tube to its mounting location on the High Ram as shown in **Figure 4**. Secure the dipstick tube with the factory bolt that was previously removed.

19. Remove the rag that was used to cover the boost tube opening. Make the connection between the driver side boost tube and the High-Ram. Tighten all the driver side hose clamps to 5 ft-lbs (60 in-lbs).

20. Re-connect the negative battery cables. Banks High-Ram Boost installation is now complete.

Figure 4. Exploded view of the High-Ram assembly

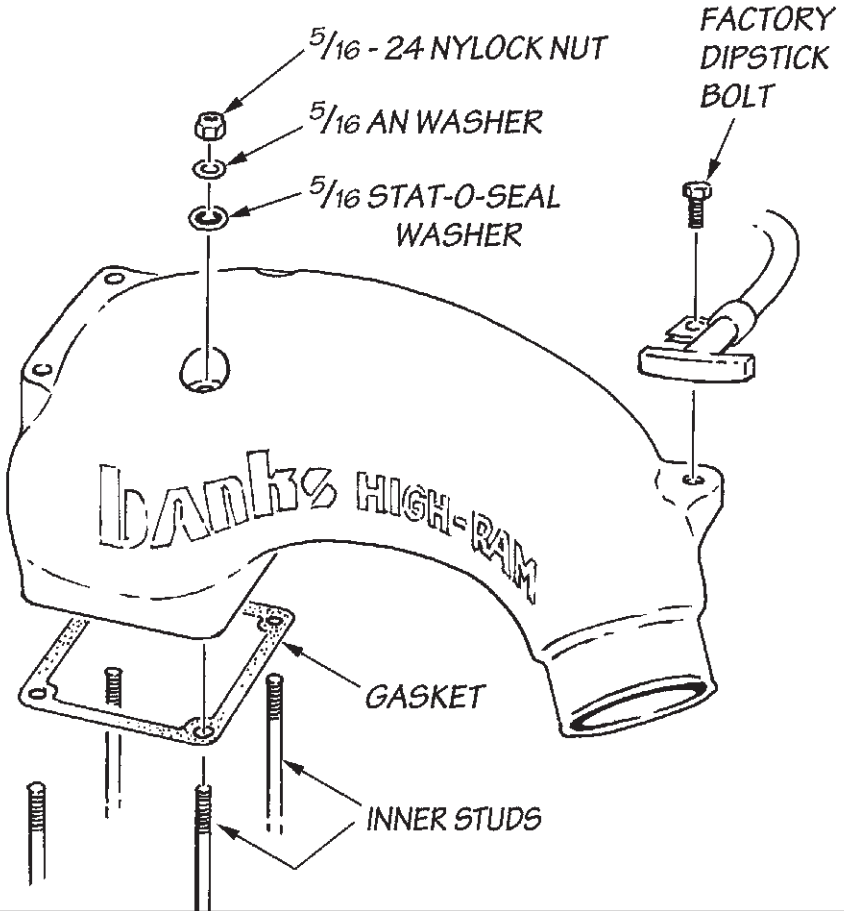

Notes

Gale Banks Engineering
546 Duggan Avenue • Azusa, CA 91702
(626) 969-9600 • Fax (626) 334-1743

Product Information & Sales: (888) 635-4565

bankspower.com