

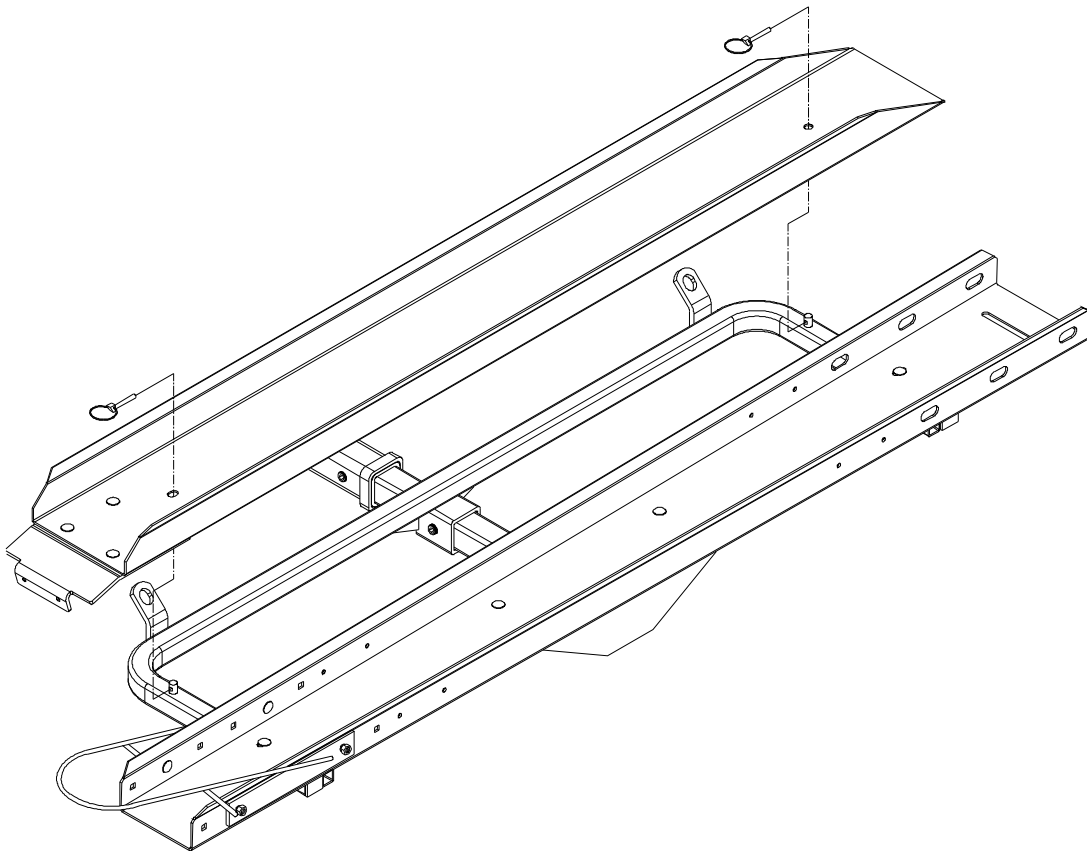

Strong As An Ox™

# MOTORCYCLE CARRIER II™



## OPERATOR, PARTS, AND INSTALLATION MANUAL

### SC2001 MOTORCYCLE CARRIER II™

Carrier Combined Capacity of 600lb.



## SC2001 Owner's Manual Motorcycle Carrier II

Serial No.

Congratulations in buying the SC2001 Motorcycle Carrier II from Blue Ox. A quality product Blue Ox that will give you many years of use.

The Motorcycle Carrier II is designed for pickup's, SUV's and other vehicles that have a Class III or greater, 2"square, trailer hitch receiver.

The following limitations must be observed for safe use of this product:

1. The combined weight of the motorcycle and carrier is **not** to exceed the tongue weight rating of the hitch receiver.

Note: The tongue weight rating is normally about 10% of the vehicle's total towing capacity and is normally labeled on the receiver or stated in the vehicle user's manual. **For example:** If your vehicle can tow a trailer weighing 5,000 lbs., it must be able to support 10% of that weight on the receiver hitch - 500 lbs. in this example.

Example:	Motorcycle Carrier II	200 lbs.
	Bike	<u>+370 lbs.</u>
	Required tongue weight rating Minimum =	570 lbs.

2. The weight of the motorcycle is **not** to exceed the 600 lb. capacity of the Motorcycle Carrier II.

### Be sure that you read the Owner's Manual completely to assure a proper and safe installation.

**IMPORTANT:** Use only genuine factory replacement parts on your Motorcycle Carrier. Do not substitute homemade or nontypical parts. If a bolt is lost or in need of replacement, for your safety and the preservation of your Motorcycle Carrier, be sure to use a replacement bolt of the same grade (Usually Grade 5, refer to parts list). Repair parts may be ordered through your nearest **Blue Ox** dealer or distributor.

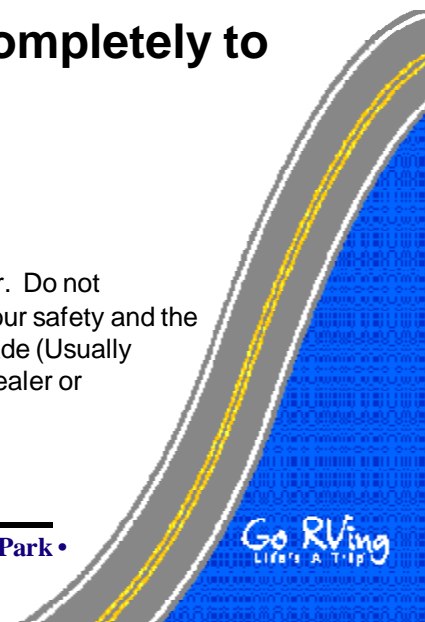



Strong As An Ox™

## TOOLS REQUIRED FOR ASSEMBLY

9/16" Socket  
Loctite Red

11/16" Socket

3/8" Allen Wrench

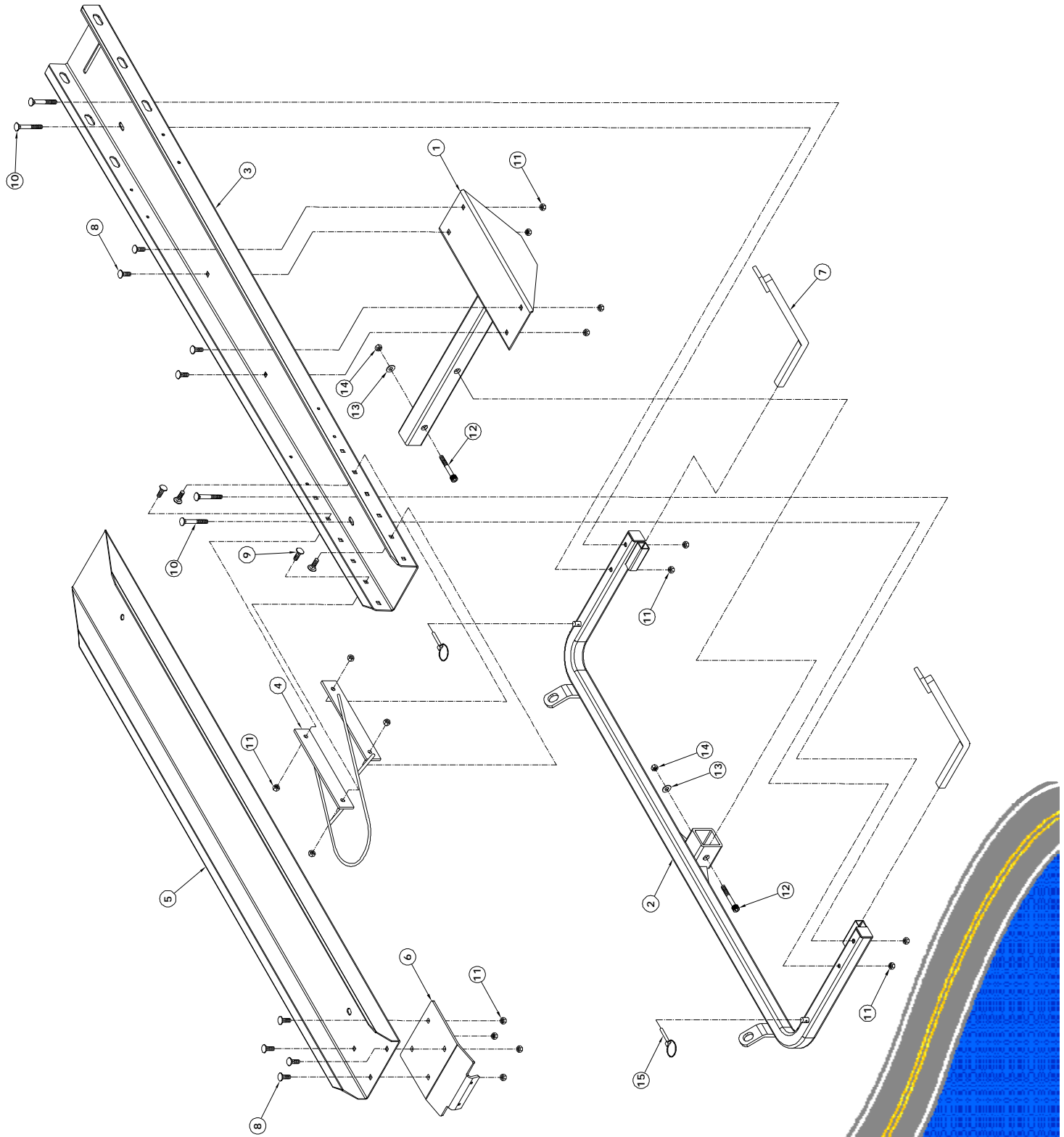



Strong As An Ox™

### Parts List

Ref. No.	Qty.	Part No.	Description
1	1	61-6099	Weldment, Stinger, SC2001
2	1	61-6100	Weldment, Tube Frame, SC2001
3	1	101-6743	Motorcycle Deck, SC2001
4	1	299-0376	Weldment, Tire Support, ZP
5	1	101-6751	Motorcycle Ramp, SC2001
6	1	101-6752	Connecting Plate, SC2001
7	2	61-6067	Weldment, Tie Down
8	4	201-0284	3/8-16 x 3/4" Carriage Bolt, Gr 5, ZP
9	8	201-0034	3/8-16 x 1" Carriage Bolt, Gr 5, ZP
10	4	201-0178	3/8-16 x 2 1/2" Carriage Bolt, Gr 5, ZP
11	16	202-0090	3/8-16 Nylon Hex Insert Lock Nut, ZP
12	2	201-0773	7/16-14 x 2 3/4" Cap Head Screw, Gr 5, ZP
13	2	203-0004	7/16" Flat Washer, ZP
14	2	202-0128	7/16-14 Nylon Hex Insert Lock Nut, ZP
15	2	84-0001	Quick Pin Assembly

## Motorcycle Carrier II Assembly

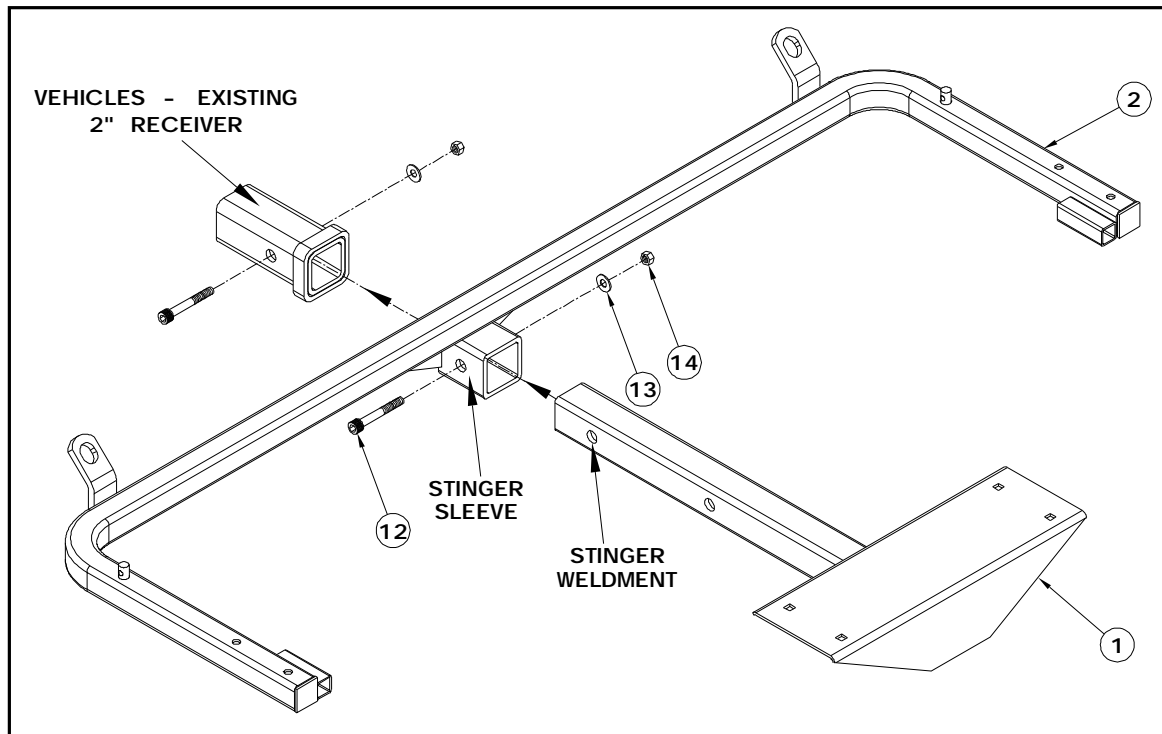

1. Insert stinger weldment into the stinger sleeve and tow vehicle's receiver to align 5/8" pin holes. Insert 7/16-14 x 2 3/4" cap screw (item 12) into receiver, tighten flat washer and 7/16-14 hex nut using the 11/16" socket and 3/8" allen wrench. **Torque 7/16-14 hex nuts to 54 ft. lbs.** Slide stinger sleeve back, align holes of stinger and sleeve. Insert 7/16-14 x 2 3/4" cap screw into hole, put on the 7/16" flat washer and 7/16 nylon hex locking nut. But do not tighten.



Strong As An Ox™

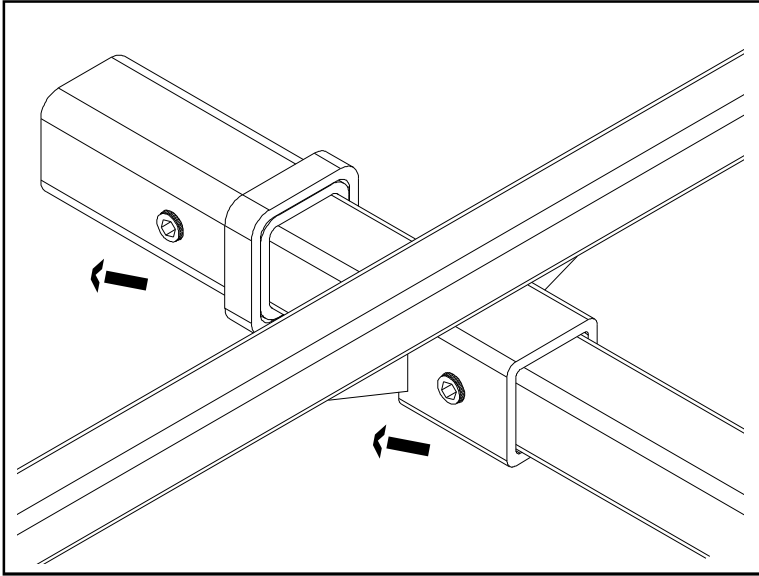

**NOTE:** The head of the 7/16-14 x 2 3/4" cap head screws are recessed into the 5/8" opening of receiver and stinger sleeve. This will allow stinger to be pulled to one side and eliminate stinger to wobble.

2. Align the square holes of the motorcycle deck (item 3) with the stinger weldment (item 1) holes, insert the four 3/8-16 x 1" carriage bolts into the four holes and finger tighten the 3/8-16 nylon hex locking nuts on the bottom side of stinger weldment. Insert the 3/8-16 x 2 1/2" carriage bolts through the square hole of the deck, into the frame and tighten 3/8-16 nylon hex lock nuts with the 9/16" socket.

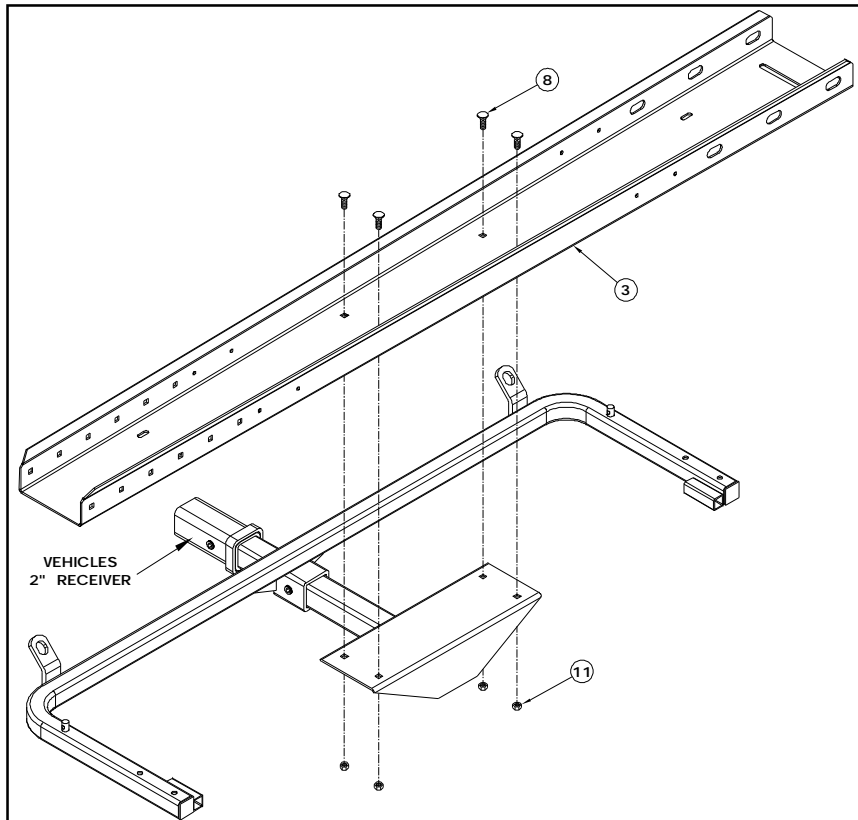

Using the 9/16" socket, tighten the four hex nuts on the bottom side of stinger weldment.

**Torque 3/8"-16 hex nuts to 33 ft. lbs.  
Torque 7/16"-14 hex nuts to 54 ft. lbs.**

**NOTE:** Carrier deck is shown as set up for curb side loading, but can be assembled with the track pointing either direction for loading from left or right. Do not use a washer on the head of the vertical carriage bolts. The bolt head should go through the square openings of the deck in the short outer tube section and rest against the main tube.



Strong As An Ox™

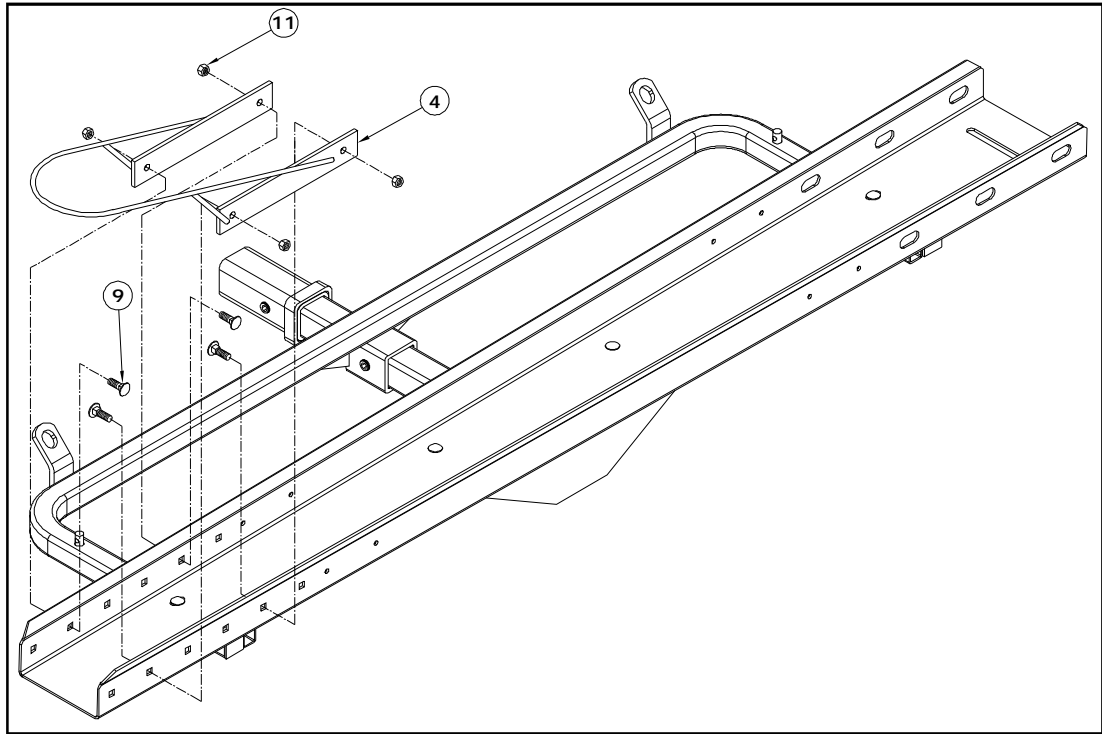

3. Slide the tire support weldment flats (item 4) on the outside edge of the narrow end on the motorcycle deck (item 3) to align the square holes of the deck with the round holes on the tire support. Insert the 3/8-16 x 1" carriage bolt into the square holes on the inside track of decking and tire support, tighten the 3/8-16 nylon hex locking nuts on the outside edge of tire support flats with the 9/16" socket. **Torque 3/8-16 hex nuts to 33 ft. lbs.**

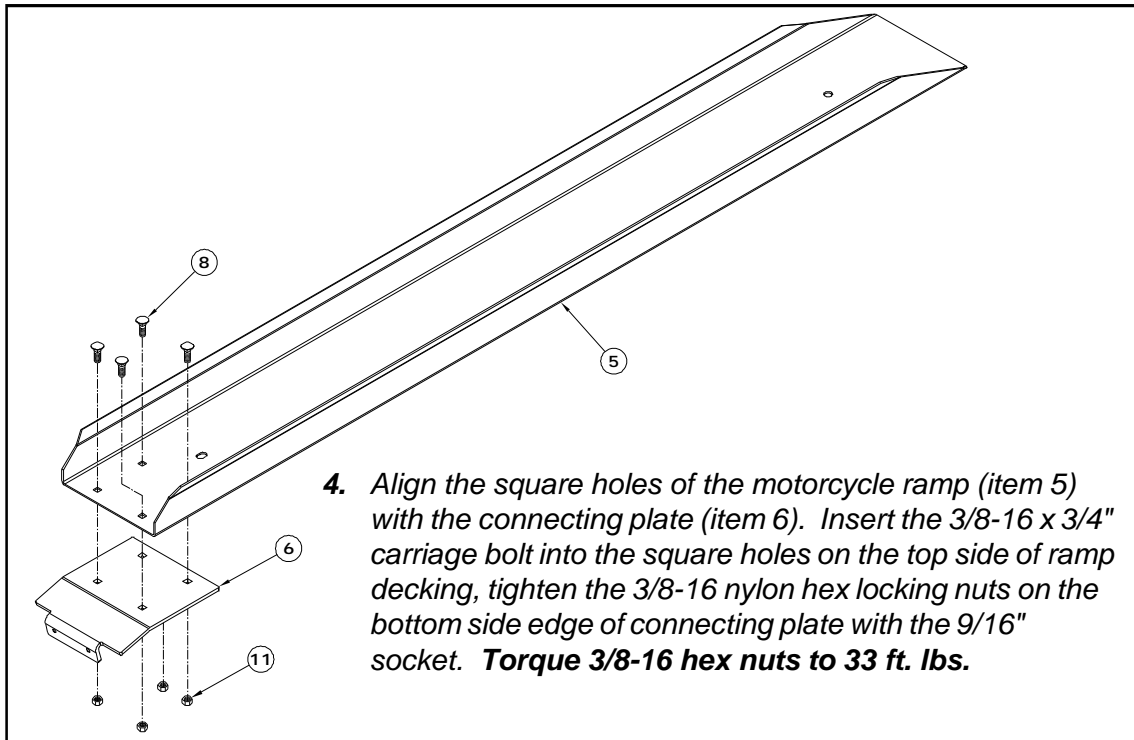

4. Align the square holes of the motorcycle ramp (item 5) with the connecting plate (item 6). Insert the 3/8-16 x 3/4" carriage bolt into the square holes on the top side of ramp decking, tighten the 3/8-16 nylon hex locking nuts on the bottom side edge of connecting plate with the 9/16" socket. **Torque 3/8-16 hex nuts to 33 ft. lbs.**





Strong As An Ox™

5. Stow the ramp next to the carrier track by aligning motorcycle ramp with the ramp attachment studs, set ramp on top of frame tubing and insert the quick clip into the attachment stud as shown in the drawing to the right.

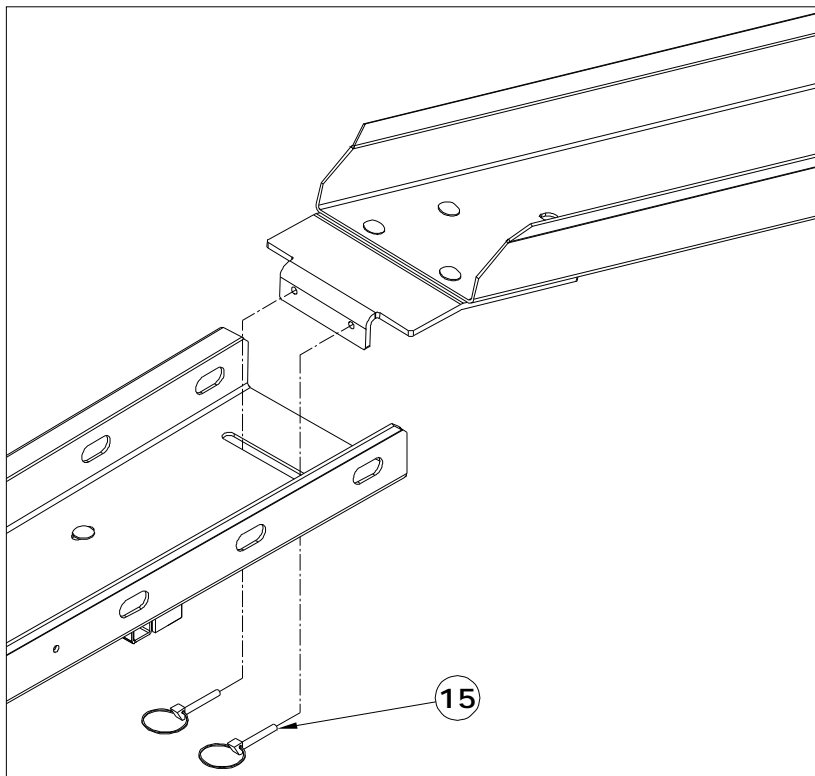
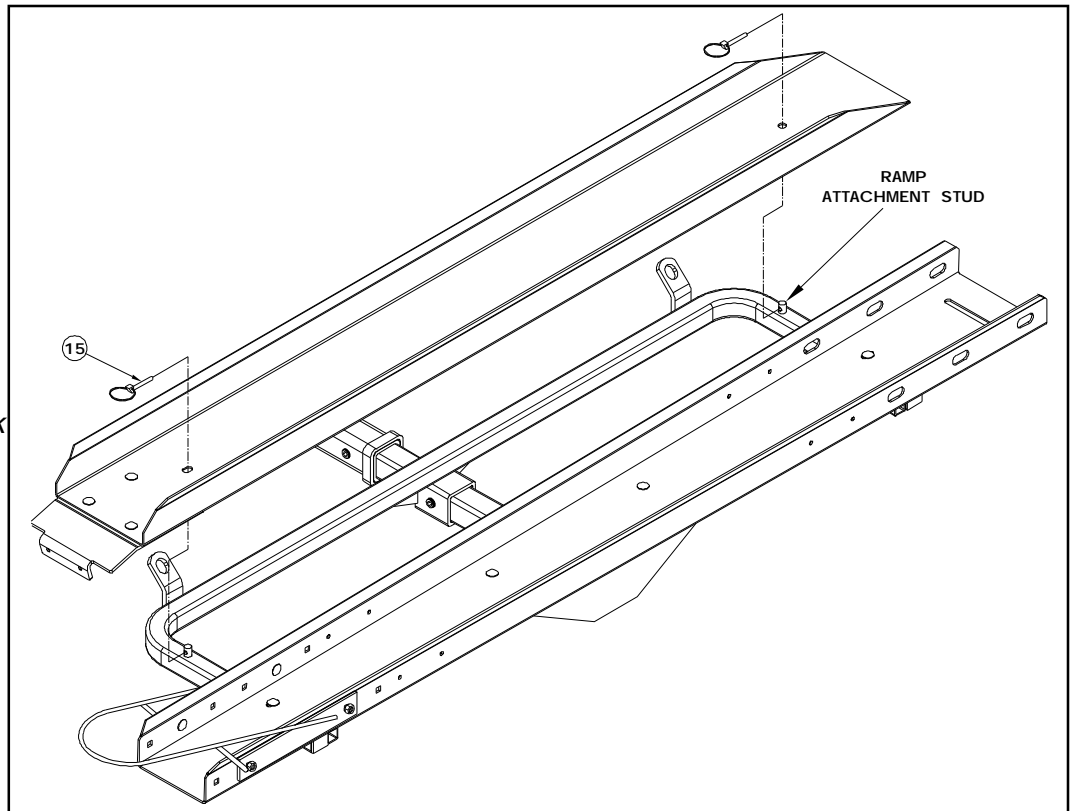

6. To prepare your motorcycle carrier for loading, remove the ramp from the motorcycle carrier, set the connecting plate flange into the slot at the end of the deck and insert the quick clips into the holes in the flange to stabilize the ramp for loading.



Strong As An Ox™

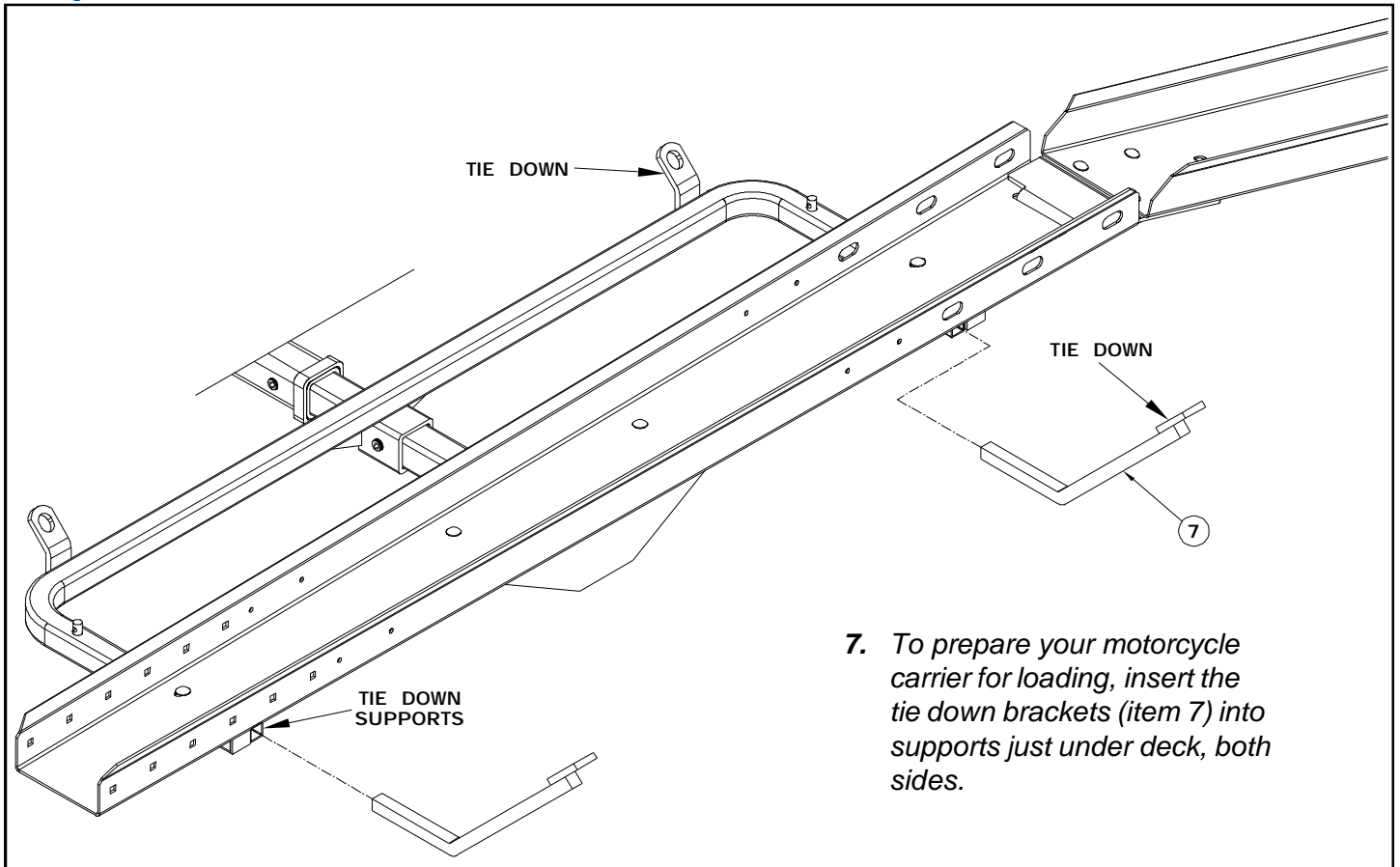

7. To prepare your motorcycle carrier for loading, insert the tie down brackets (item 7) into supports just under deck, both sides.

### LOADING INSTRUCTIONS

8. With ramp in place, roll the bike up the ramp and onto the carrier. Secure the bike with four tie downs using the tie down brackets. Use two tie-downs to secure the handlebars to the two front tie down brackets (shown in drawing above), compressing the suspension sufficiently so that the bike is secured tightly. Secure the rear tire using a tie down on the back tie down brackets. Run a tie-down from one foot peg under the deck to the other foot peg, then cinch down as tight as possible. **NOTE: After loading, the bike should be about vertical to the ground, not tilted to either side. Secure the loose ends of the tie-downs straps. Do not let them hang free.**





Strong As An Ox™

## **Do's and Don'ts**

### **Do:**

1. *Inspect the Motorcycle Carrier II before each use for any damage or defects. Do not use if any damage or defects are present.*
2. *Always use quality tie downs made for motorcycles.*
3. *Inspect tie downs for fray or wear. If present, do not use them.*
4. *Make sure to tie the foot pegs down to the Motorcycle Carrier II as well as the back tire.*
5. *Always secure the ends of the tie downs.*

### **Don'ts:**

1. *Use the Motorcycle Carrier II for uses other than those described in this instruction manual.*
2. *Haul more weight (bike and carrier combined) than the tongue weight rating of your vehicle.*
3. *Modify or change the Motorcycle Carrier II.*



Strong As An Ox™

**TO BE VALID, THE WARRANTY CARD MUST BE COMPLETED IN ITS ENTIRETY BY AN AUTHORIZED DISTRIBUTOR OR DEALER AND SENT TO AUTOMATIC EQUIPMENT MFG. CO., PENDER, NEBRASKA. FAILURE TO DO SO WILL VOID THE WARRANTY.**



### **Customer Service Commitment**

Blue Ox is focused on providing exemplary customer service, as observed in our mission statement and guiding principles. In accordance with this objective, Blue Ox is proud to provide services such as repairs and general maintenance of Blue Ox products at over 150 RV rallies. Look for our Destination America or Blue Ox Racing service crews at the next rally or race you attend. If you miss them, you may find an informative, personalized note explaining any service they may have provided your Blue Ox products in your absence.

Blue Ox also offers educational seminars at rallies and through our Park & Resort teams. In addition, Blue Ox customers visiting our factory may take advantage of free use of the well-equipped Blue Ox RV Park.