



SportLoader™

By OverBilt®

Owner's Manual



Serial Number



SC3000
(for long box
pickups)

SC3001
(for short box
pickups)

THANK YOU

for purchasing an OverBilt® SportLoader™ from Blue Ox®. We've organized this manual to make your installation simple and as trouble-free as possible. Please read it thoroughly before proceeding. Remember to keep your sales receipt and this manual in a safe place so that both are available for future use if necessary.

SportLoader™ from Overbilt®

WARRANTY INFORMATION

One Year Warranty

Automatic Equipment Manufacturing Company ("Automatic") warrants to the original retail purchaser that each product manufactured by Automatic shall be free from defect in material and workmanship under normal use and service for a period of one year from the date of delivery. In the case of equipment used for commercial or rental purposes, such warranty period is limited to 30 days from the date of delivery to the original retail purchaser.

During said one-year period (30 days in the case of equipment used for commercial or rental purposes), Automatic will repair or replace any parts which (a) shall be returned to an authorized dealer, distributor, or the factory, with transportation charges prepaid, and (b) after examination by Automatic, are found to be defective. This limited warranty will not cover, in any way, any alleged damages caused by incorrect or improper installation, improper use, modification or neglect of product, or failure of the user to follow the guidelines contained in the instructional material provided by Automatic.

REPAIR OR REPLACEMENT AS SET FORTH IN THIS LIMITED WARRANTY IS THE SOLE EXCLUSIVE REMEDY OF THE PURCHASER. AUTOMATIC SHALL NOT BE LIABLE FOR ANY INCIDENTAL OR CONSEQUENTIAL DAMAGES FOR BREACH OF ANY EXPRESS OR IMPLIED WARRANTY ON THIS PRODUCT. EXCEPT TO THE EXTENT PROHIBITED BY APPLICABLE LAW, ANY IMPLIED WARRANTY OF MERCHANTABILITY OR FITNESS FOR A PARTICULAR PURPOSE ON THIS PRODUCT IS LIMITED IN LENGTH TO THE DURATION OF THIS WARRANTY.

Some states do **NOT** allow the exclusion of incidental or consequential damages, or allow limitations on how long an implied warranty lasts, so the previous limitations or exclusions may **NOT** apply to you. This warranty gives you specific legal rights and you may also have other rights which vary from state to state.

Automatic reserves the right to make changes or add improvements to its products at any time without any obligation to make such changes to previously manufactured equipment.

No liability is assumed for bodily injury that may be inflicted on the operator, spectator or general public who is in the general area while this equipment is in use.

IMPORTANT

Coverage and performance under the foregoing limited warranty is conditioned upon the original retail purchaser completing and returning the customer registration card to Automatic or registering via our website www.blueox.us within ten days of delivery date and upon the original serial number being visible on the product and unaltered. Automatic will **NOT** honor any warranty claims unless the warranty registration card is on file at Automatic's factory in Pender, Nebraska. Some states do **NOT** allow exclusions or limitations of warranty coverage based on the return of the registration card to the manufacturer, so the above limitations may **NOT** apply to you.

Blue Ox® Division
Automatic Equipment Mfg. Co.
P.O. Box P
Pender, Nebraska 68047

24/7 Customer Care (402) 385-3051 or Toll Free (888) 425-5382

Product Information & Table of Contents

Equipment Information Record

Date Purchased: _____
Purchased From: _____
Address: _____
State: _____ Zip Code: _____
Phone Number of Dealership: _____
Installed By: _____
Service #: _____
Model #: _____
Serial #: _____

Notes: _____

 **WARNING**

Improper installation and/or operation can create a hazard which can cause serious injury, property damage or death. Improper installation and/or operation will void the warranty.

Table of Contents

Page I
Warranty Information

Page II
Equipment Information Record
24/7 Customer Care Information
Safety Warning

Page 1
Product Information

Page 2
Welcome to Blue Ox
Unpacking

Page 3
Parts List

Pages 4-5
Installation

Pages 6-7
Loading

At Blue Ox® we pride ourselves in offering exceptional customer service to our valued customers.

If you have any questions, comments, or concerns please feel free to contact a member of our 24/7 Customer Care Team by calling (402) 385-3051 or toll free at (888)425-5382.

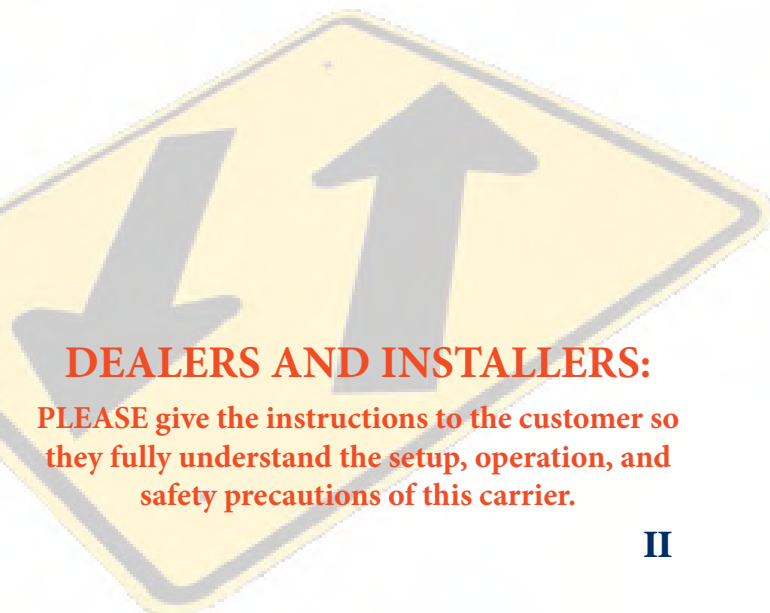

DEALERS AND INSTALLERS:
PLEASE give the instructions to the customer so they fully understand the setup, operation, and safety precautions of this carrier.

SportLoader™ Motorcycle Carrier from Overbilt®

Description of your product.

The SportLoader™ allows you to take your motorcycle along anywhere that you roam.



provides ample power to load motorcycle into your pickup truck and safely unload. There are no cables to worry about.

This powerful 12-volt motor and removable corded control makes loading and unloading your motorcycle a snap. The SportLoader requires a 12-volt (lawn and garden tractor) battery, which is not included.

The new Overbilt® SportLoader™ manufactured by Blue Ox® is the safest and most effective method for transporting your motorcycle using your pickup truck. The motorcycle is loaded safely and easily into the bed of your pickup truck. The SportLoader can be installed on virtually any pickup, short or long bed versions. As with many products manufactured by Blue Ox, minimal installation is required.

"I love my SportLoader™ – no death defying ride up the ramps, no trailers, no hassles. I'm able to load my bike by myself with ease. I now take my bike more places and when I'm done – I just take it out of the pickup. There are no modifications and installation was a breeze!"

SportLoader is equipped with a hand crank that clamps and holds the tire of the motorcycle as it sits in the tire cradle. Tie-downs are required for holding the motorcycle in position for transport.

The SportLoader lift features a durable powder-coated finish that prolongs product

An electric motor with a positive gear drive



life and prevents rusting. Your motorcycle sits approximately one inch off the bed of the pickup truck—keeping your motorcycle well protected and its center of gravity as low as possible.

Welcome to the Blue Ox® Experience.

Congratulations on purchasing your SportLoader™. The SportLoader design uses the latest technology and the highest quality materials. The SportLoader is designed to load and haul a motorcycle in the back of your pickup truck.

BEFORE using the Overbilt® SportLoader™ manufactured by Blue Ox®, **READ THESE INSTRUCTIONS THOROUGHLY**. You will find operating instructions, installation instructions, and safety precautions enclosed in this owner's manual. Read these instructions carefully and precisely follow these instructions. **REMEMBER**, proper installation and use of this product is the sole responsibility of the user. Improper installation, use or maintenance may result in malfunction or property damage. Please fill out your warranty card and mail it back to Blue Ox, or register your product(s) at www.blueox.us. For future reference, your serial number is located on the back cover of this manual and it is located on your SportLoader tire cradle.

Unpacking your SportLoader™

Remove the SportLoader from the shipping carton, referencing the parts list on this page or diagram on page 3. Verify that you have all of the parts **BEFORE** you start the installation process. If you do **NOT**, please contact a Blue Ox dealer or distributor or you can contact a member of Blue Ox's 24/7 Customer Care Team at (402)385-3051 or toll free at (888) 425-5382 to order replacement parts. **DO NOT** use homemade or non-typical parts.

Parts List

Ref. No.	Qty.	Part #	Description
1	1	61-6155	(SC3000) Weldment Ramp 104" (long box)
		61-6195	(SC3001) Weldment Ramp 86" (short box)
2	1	61-6156	Tire Cradle
3	1	61-6152	Weldment, Ramp Extension Mid
4	1	61-6153	Weldment, Ramp Extension End
5	1	61-6190	Bully Jack, Weldment (SC9012)
6*	4	201-0295	5/16-18 x 1 Flat Soc Hs Screw
7*	4	202-0002	5/16-18 Hex Nut, ZP
8*	4	203-0009	5/16 Lock Washer, ZP
9*	4	203-0002	5/16 Flat Washer, ZP
10*	2	270-0061	Cargo Buckle
11*	2	201-0691	7/16-14 x 1 Hex Head Bolt Grade 5
12*	2	202-0002	7/16-14 Hex Nut, ZP
13*	2	203-0003	7/16 Flat Washer, ZP
14*	2	203-0011	7/16 Lock Washer, ZP
15	1	294-0891	Winch, 12volt, No Sprocket
16*	1	294-0892	Solenoid, 12volt
17*	2	201-0691	3/8-16 x 1 1/4 Hex Head Bolt
18*	2	202-0003	3/8-16 Hex Nut
19*	2	203-0004	3/8 Flat Washer
20*	2	203-0010	3/8 Lock Washer
21*	1	229-0705	Gear, 8DP-14.5PA, 20T, 2.75OD, 1.25
22*	2	209-0141	Bearing, 5/8 Flange, Navigator
23*	8	229-0707	Wheel 3
24	2	229-0520	Pin, 1/2 x 2 5/8 EFF
25	2	84-0001	Quick Pin Assembly
26	1	294-0899	Corded Control

* Not visible in the drawing.

SC3000, SC3001

Parts Drawing

Figure 1-A

Main Ramp and Tire Cradle

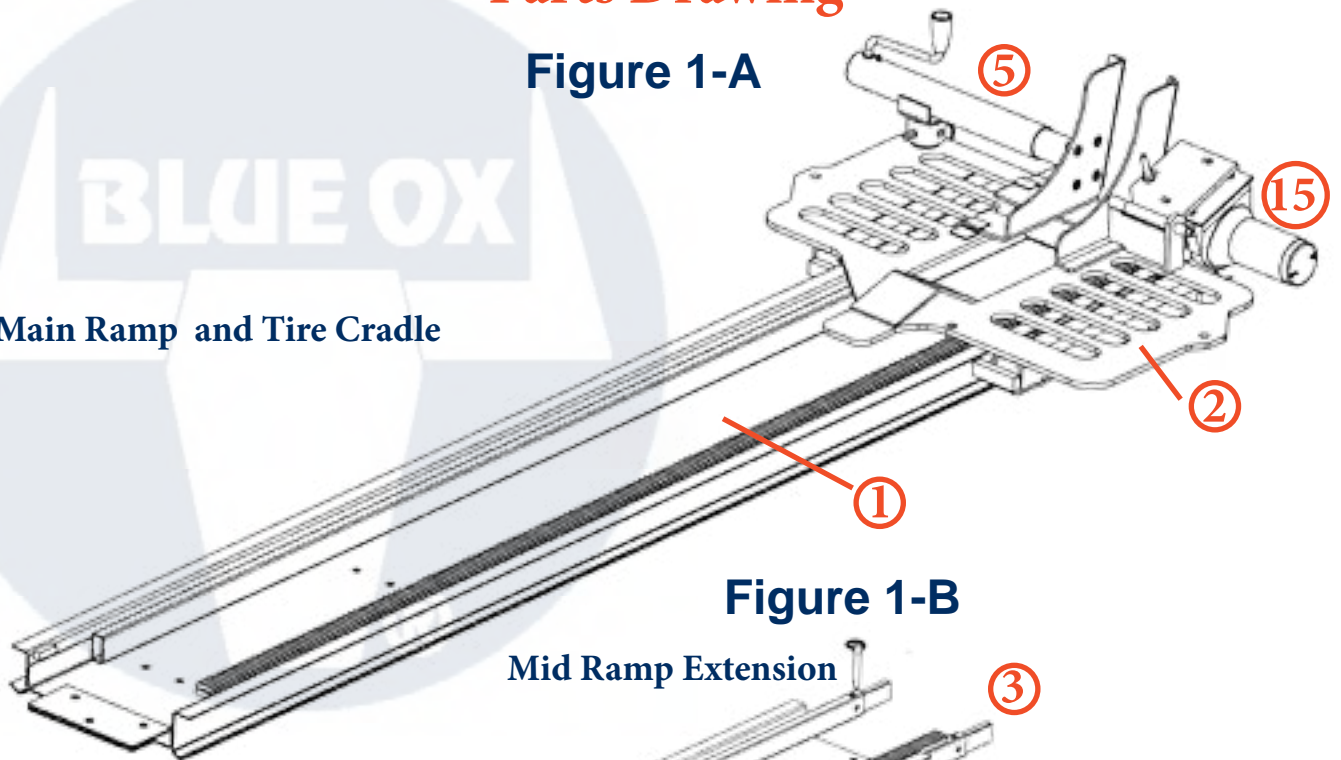

Figure 1-B

Mid Ramp Extension

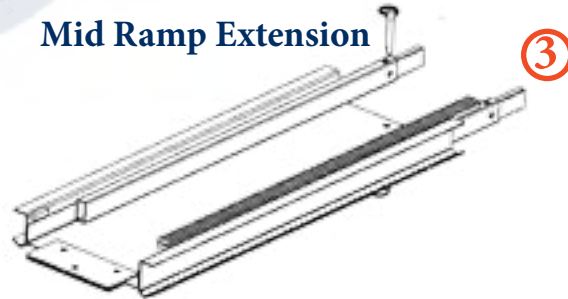

Figure 1-D



Corded Control

Figure 1-C

End Ramp Extension

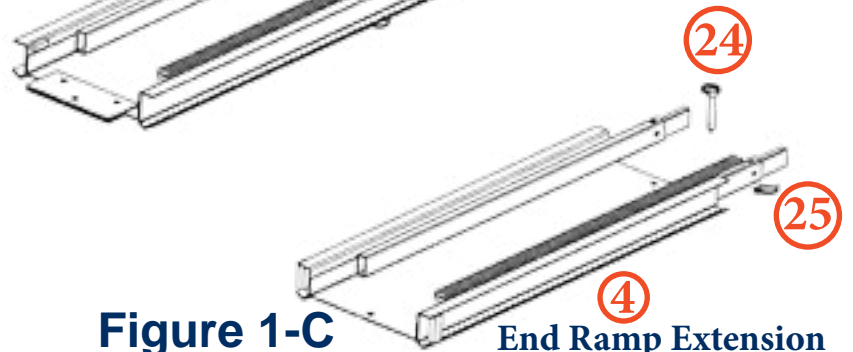

See page 2 for complete parts list.

Figure 1-E

Pivot Tube
(packaged separately)

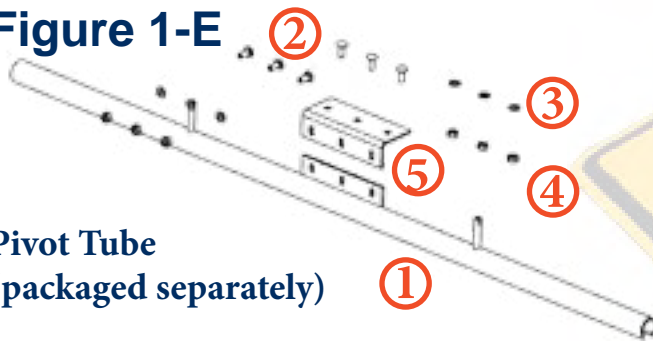

Parts List

Ref.#	Qty.	Part #	Description
1	1		Pivot Tube
2	6	201-0034	3/8-16 x 1 Carr. Bolt Grd. 5, ZP
3	6	203-0003	3/8 Flat Washer, ZP
4	6	202-0090	3/8-16 Hex Nylon Insert Lock Nut, ZP
5	1	102-6651	Ramp Adjustor Plate
6	12	290-0450	Plastic Washer (not shown)

Installation

1. Remove the tailgate from your pickup according to manufacturer's instructions.

NOTE: The tailgate cannot be reinstalled unless the SportLoader™ is removed from the box of your pickup truck.

2. Slide the pivot tube onto the OEM tailgate mount on the left or driver's side of truck bed (Figure 2A). Slide the slotted end over the OEM tailgate mount (Figure 2B) on the right (passenger's) side of truck bed.



3. Rotate pivot tube until the ramp adjustor plate (affixed to the pivot tube) does not obstruct the loading of the main ramp assembly into the bed. Figure 3 shows the tailgate pivot tube once in place.



4. Put the main ramp into pickup truck box. See main ramp in diagram on page 3 or shown in Figure 5 with tire cradle (61-6155 for long bed and 61-6195 for short bed). Slide until it is **ONLY** approximately one inch from the front of the bed of the pickup truck box. The electric motor side of the main ramp should be on the passenger's side of the pickup truck bed.



5. Insert and tighten six 3/8"-16x1" bolts, 3/8" flat washers, and 3/8"-16 nylon hex lock nuts (bolts 201-0034, flat washers 203-0003, nylon insert lock nut 202-0090) to fasten main ramp to pivot tube (Figure 4). Reference the pivot tube instructions included in the pivot tube packaging.



 **CAUTION**

Be sure to put **ALL** bolts in **ALL** ramps. Failure to do so could result in personal injury and/or property damage.

6. Install battery (12-volt lawn and garden tractor style battery, not included). Remove the strap and then the lid from the battery holster to place a 12-volt battery inside.
7. Slide the ramp extensions onto the main ramp. The mid ramp extension slides on first (Figure 6). The illustration on page 3 shows these as 61-6152 (mid extension) and 61-6153 (end extension).
8. Insert the ½-inch pins (229-0520). One pin fastens the mid ramp and end ramp extensions to each other. The other pin fastens this assembled ramp extension to the main ramp. Figure 7 shows the ramp extensions fastened with the ½-inch pin.
9. Attach corded control to the electrical connection near the battery and motor. Make sure the cord is away from **ALL** moving parts. If it is **NOT** clear of the rack, damage could occur.

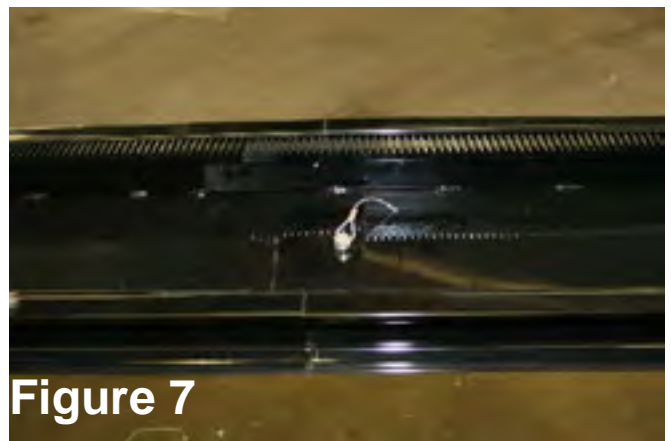

CAUTION

Be sure to install the 2 tethered pins and clips in the ramps. **FAILING** to do so could result in personal injury and/or property damage. (Figure 7)

KEEP YOUR HANDS AWAY FROM MOVING PARTS.

Make sure area around the SportLoader™ is clear of all bystanders. The operator is the only person who needs to hold the ramp so it does **NOT** slam into the ground or truck bed when operated.

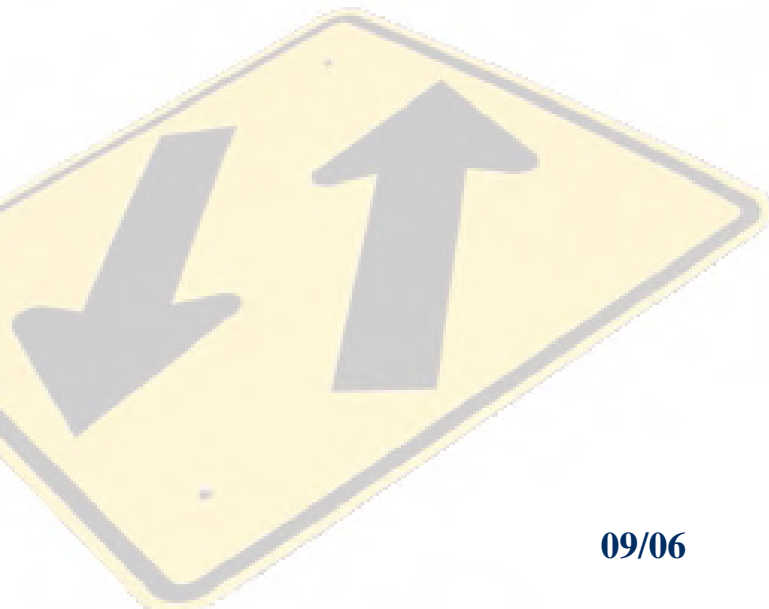

Loading

1. While using the corded control, hold the ramp to prevent uncontrolled tilting of the SportLoader. Press the button to start lowering the SportLoader. As the cradle nears the ground, let it rest on the ground (Figure 8). **Do NOT** let it push into the ground. You could cause damage to your SportLoader.
2. Verify that the clamp (tire backing plates) is slightly wider than the width of the tire. Verify the motorcycle is in neutral and roll it carefully onto the cradle (Figure 9).
3. Use the hand crank to close the clamp and hold the tire in place (Figure 10).
4. Two CargoBuckles are mounted to the tire cradle. (Figure 11) To further stabilize the motorcycle during loading, secure an “S” hook to handlebar and ratchet tight on both sides.
5. Operate the SportLoader by using the removable corded control switch. As the bike moves up the ramp, control the pivoting movement until the main ramp assembly comes to rest in the pickup bed (Figure 12).
6. After the main ramp assembly is resting on pickup bed, use the corded control to move the motorcycle forward until it stops short of the front of the pickup bed.
7. Remove and store ramp extensions in back of pickup.
8. Use tie-downs to strap down the rest of the bike. Installation and loading is complete.

Use additional tie downs (not included)—securing the bike to the pickup bed in a minimum of four additional places.
9. Periodically check straps during travel to make sure straps are secure.



Figure 8



Figure 9



Figure 10



Figure 11



Figure 12

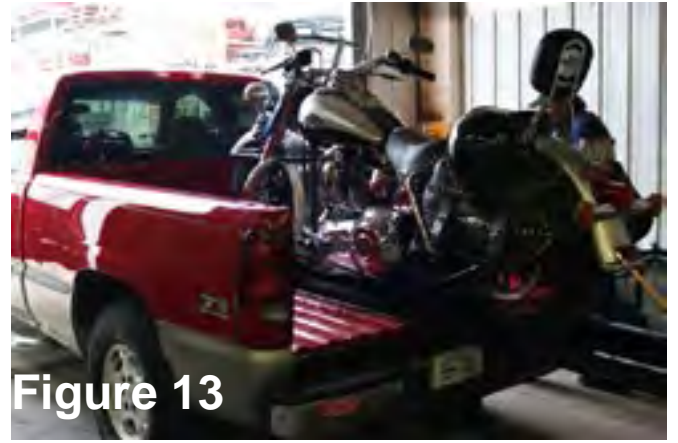

Figure 13



Figure 14

CAUTION

Tie down your motorcycle in a minimum of four additional locations.

TROUBLESHOOTING

- If the second of the two ramp extensions does not install properly during assembly, verify that they are in the correct positions. See page 3 for an illustration and pages 4 and 5 for the installation.

- In the unlikely event that the gear for the cradle on the main ramp should slip, simply torque the center adjustment bolt to 20 ft. lbs. to prevent future occurrences. See Figure A below for the location.

- If necessary, stop the bike short of the ramp pin when loading. Remove the pin and load the bike. Do this if one tire covers the ramp pin needing to be removed when taking apart the ramp.

Wiring Schematic

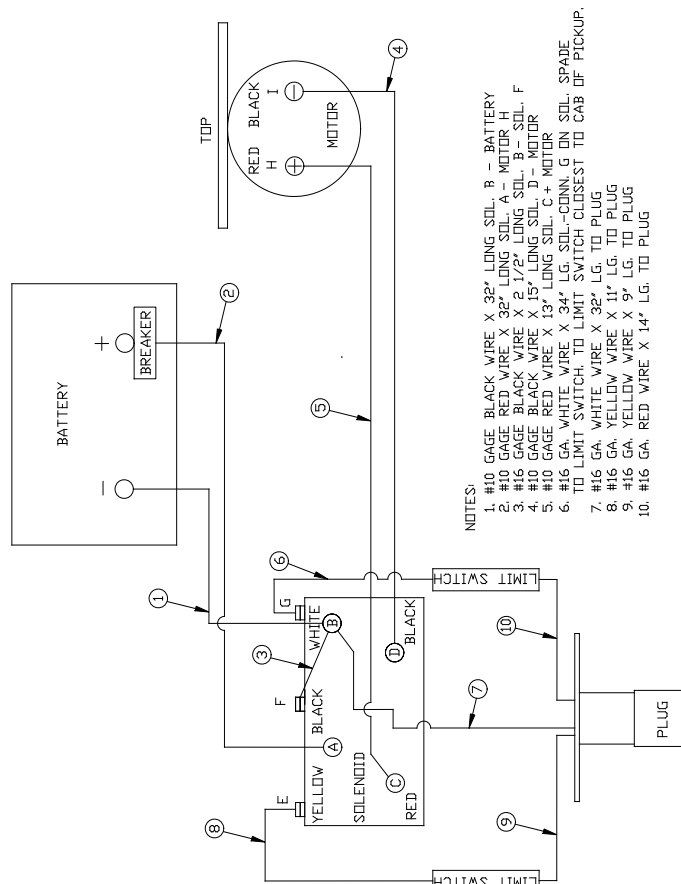
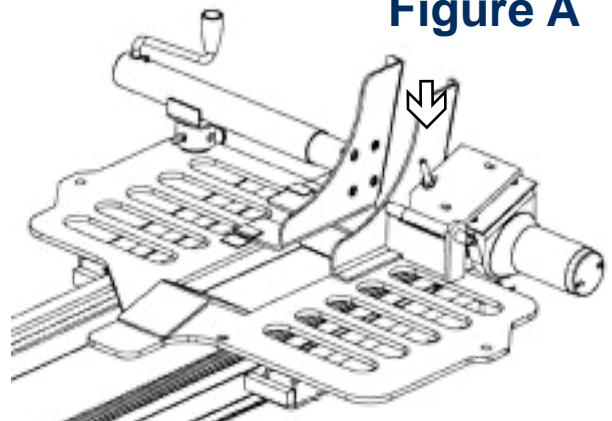

Figure A



Don't trust your equipment to just any carrier. Instead, rely on strong, durable carriers from the company synonymous with safe, reliable RVing. Blue Ox®.

Serial Number



Customer Service Commitment

Blue Ox® is focused on providing exemplary customer service, as observed in our mission statement guiding principles. In accordance with this objective, Blue Ox® is proud to provide services such as repairs and general maintenance of Blue Ox® products at over 150 RV Rallies. Look for our Destination America or Blue Ox® Racing service crews at the next rally or race you attend. If you miss them, you may find an informative, personalized note explaining any service they may have provided your Blue Ox® products in your absence.

Blue Ox® also offers educational seminars at rallies and through our Parks & Resort teams. In addition, Blue Ox® customers visiting our factory may take advantage of free use of the well-equipped Blue Ox® RV Park.



Blue Ox • One Mill Road, Industrial Park • Pender, Nebraska 68047
Phone: (402) 385-3051 • Fax: (402) 385-3360 • www.blueox.us