



Installation Instructions

6L80 Cast Aluminum Deep Transmission Fluid Pan

**SPECIFICALLY DESIGNED FOR 2010-2014 CAMARO SS (V8)
Part Number 70391**

(see www.bmracing.com for the latest vehicle fitment applications and model years)

© 2013 by B&M Racing and Performance Products

Congratulations! You have just purchased one of the finest cast aluminum pans available for the GM 6L80 transmissions. This **B&M Cast Aluminum Deep Transmission Fluid Pan** has been designed to work on most GM vehicles equipped with 6L80 transmissions (specifically 2010-2014 Camaro SS equipped with an automatic transmission). The **B&M Cast Aluminum Deep Fluid Pan** provides several advantages over stock factory oil pans. The extra capacity provides increased oil volume and added cooling, while the finned aluminum construction increases case rigidity and improved heat transfer. The magnetic drain plug feature allows regular transmission maintenance and oil changes without the usual mess associated with "dropping the pan," and limits ferrous debris from circulating in the transmission.

WARNING! This **B&M Cast Aluminum Deep Transmission Fluid Pan** has been designed with added capacity and external cooling fins which cause the pan to hang as much as $\frac{3}{4}$ " or more, lower than the original transmission pan. Extra care and caution should be taken when driving the vehicle over objects and/or straddling debris. As always, check underneath the vehicle if objects or features come into contact with under ve-

hicle components before continuing driving.

NOTE: The 6L80 transmissions do not come with a dip stick. For ease of fluid measurement and fill, it is suggested to use a B&M 6L80 Locking Dipstick P/N 22168 to measure fluid level and have a convenient location to fill the transmission.

When installing your **B&M Cast Aluminum Deep Fluid Pan** you may wish to consider a **B&M Transmission Temperature Gauge**. Most transmission and converter failures can be traced directly to excessive heat. This accurate temperature gauge comes with a light kit, color-coded dial face, antiglare enclosure, wires, terminals, special sending unit, and T-fitting for easy installation. Available at your **B&M** dealer.

INTRODUCTION

This deep fluid pan can be installed in about an hour by carefully following the instructions. Check the tool list at the end of these instructions for the tools required to install your **B&M Cast Aluminum Deep Fluid Pan**. Transmission components are precision fit and dirt is the number one enemy of an automatic transmission. Automatic transmissions operate at tem-

peratures between 150°F and 250°F. It is suggested that the vehicle be allowed to cool off for a few hours to avoid burns from hot oil and parts. The vehicle should be off the ground for ease of installation – jack stands, wheel ramps or a hoist will work fine. **MAKE SURE VEHICLE IS FIRMLY SUPPORTED - DO NOT WORK UNDER A VEHICLE IF IT IS SUPPORTED BY ONLY A JACK!** Try to raise the vehicle 1-2 feet so you will have plenty of room to work. Also, have a small box to put bolts in and a drain pan to catch oil.

NOTE: This kit does not come with a transmission filter or gasket.

INSTALLATION

BEFORE BEGINNING INSTALLATION IT IS RECOMMEND TO INSTALL B&M 6L80 LOCKING DIPSTICK P/N 22168 FIRST TO INSURE CORRECT FLUID FILL LEVEL!

STEP 1. Place a drain pan underneath transmission. To drain the oil pan, first unscrew the rear center oil level check plug, using a 14mm deep socket and ratchet (**see figure 1**). Allow the transmission fluid to drain and then re-install the check plug.

NOTE: At this point only a small portion of the fluid in the pan has

drained (~ 1.5 quarts (1.4L) – cold transmission).

STEP 2. Loosen two opposing corner bolts and remove the rest of the pan bolts using a 10mm socket, extension, and ratchet. If the pan and gasket sticks, pry it down slightly with a screwdriver to break the seal (see figure 2).

NOTE: Be careful not to damage the transmission surface and/or pan gasket as leaks could develop.

STEP 3. Carefully remove the two remaining corner bolts while holding the pan and lower the pan without spilling the remaining fluid. The pan will be about 7/8 or more, full of fluid (~4 quarts (3.8L)), so keep the pan level and slowly move it out from underneath the vehicle where it can be safely drained (see figure 3).

STEP 4. Remove the magnet from the pan, fully clean it and set it aside as it will be re-used.

STEP 5. The oil filter will now be exposed. If changing the filter (recommended), pull the filter out of the valve body, being careful not to bend the filter pickup tube as it is plastic and may crack or break (see figure 4). If the seal remains in the valve body and does not come out with the filter, remove it by using a flat head screwdriver. Be careful not to damage the surface. Then install the new filter (GM p/n: 24236931).

STEP 6. Place the magnet removed earlier on the bottom of the **B&M Cast Aluminum Deep Transmission Fluid Pan** directly on top of the star feature with threaded hole (see figure 5). Using the supplied button head screw and over-sized washer, affix the magnet to the bottom of the pan and tighten with a 4mm hex wrench.

STEP 7. Place Teflon tape on the threads of the magnetic drain plug and temperature sensor plug (or sending unit if using a temperature gauge) and tighten them into the pan using a 3/8" hex wrench and 7/16" box wrench (see figure 6).

STEP 8. Using a 14mm deep socket, extension, and ratchet; remove the oil level check plug from the stock pan and install it into the oil level check recess of the **B&M Cast Aluminum**



Figure 1



Figure 2

Deep Fluid Pan. Tighten to 18 ft-lbf (25 N-m).

STEP 9. Closely inspect the transmission pan gasket for any signs of problems including, rips, tears, or excessive deformation. Replace with a new gasket (GM p/n: 24224781) if necessary. Align the gasket onto the mounting flange of the **B&M Cast Aluminum Deep Fluid Pan** and push the nubs of the gasket into the guide hole

of the pan to hold the gasket in place (see figure 7).

STEP 10. Clean the transmission mating surface with a clean rag (see figure 8).

STEP 11. Install the **B&M Cast Aluminum Deep Oil Pan** using the supplied bolts and washers (see figure 9). Using a 5mm hex drive, extension, and torque wrench tighten the bolts to 80 in-lbf (9N-m) in the sequence



Figure 3



Figure 4



Figure 5



Figure 6

shown in **diagram A**. Do not over tighten as this can cause leaks or damage to the transmission case or gasket.

STEP 14. Add ~7.3 quarts (6.9L) Dexron VI transmission fluid (only) to the transmission using one of these methods:

-Method A (preferred): With the dipstick removed, use a funnel and slowly add the transmission fluid through the previously installed **B&M 6L80 Locking Dipstick P/N 22168** tube. Pouring the fluid in too quickly can cause fluid to back-up in the tube and spill. Pour slowly and carefully.

-Method B: Locate the fill plug on the right side of the transmission case (see figure 10) and remove it by pulling it straight out from the top. Using a tube and a pump, pump the fluid into

the transmission pan through the fill plug hole.

-Method C: Remove the oil level check plug and using a tube and pump, pump the fluid into the transmission pan through the oil level check hole. NOTE: Using this method you will only be able to add ~5.8 quarts (5.5L) of fluid before the fluid starts to spill back through the oil level check hole. NOTE: Using this method you will only be able to add ~5.8 quarts (5.5L) of fluid before the fluid starts to spill back through the oil level check hole.

STEP 15. Reinstall any caps or plugs that were removed during the transmission fluid fill procedure in the previous step and then lower the vehicle.

STEP 16. Check the fluid level of the transmission. **CAUTION!** The transmission fluid level must be checked

when the operating range of the transmission fluid temperature (TFT) is between 86-122°F(30-50°C). If the transmission fluid is outside this range the level of the transmission fluid cannot be accurately determined resulting in either an over filled or under filled transmission.

A. Observe the TFT using the driver information center (DIC) or other temperature measuring tool.

B. Start and idle the engine.

C. Depress the brake pedal and move the shift level through each gear range.

Pause for at least 3 seconds in each range. Move the shift level back to PARK. Ensure the engine RPM is low (500-800 RPM).



Figure 7



Figure 8



Figure 9



Figure 10

D. Allow the engine to idle for at least 1 minute.

STEP 17. CAUTION!: THE ENGINE MUST BE RUNNING AND TFT WITHIN THE RANGE AS STATED ABOVE when the transmission fluid level is checked:

- Method A (preferred): Using the previously installed **B&M 6L80 Locking Dipstick P/N 22168** unscrew the dipstick cap and check the transmission fluid level according to the instructions. Add (see step 14) or remove fluid (use drain plug or oil level check plug) accordingly.

-Method B: Carefully raise and support the vehicle (with the engine still running and TFT in range). Ensure the vehicle is level. Remove the oil level check plug from the pan and allow any fluid to drain until the fluid begins to drip. If no fluid comes out, add fluid as described in step 14.

WARNING!: An under-filled transmission will cause premature component wear and damage. An over-filled transmission will cause fluid to discharge out the vent tube, fluid foaming, and/or pump cavitation. DO NOT operate the vehicle

with an incorrect transmission fluid level.

STEP 18. Inspect the pan gasket and any of the ports for any signs of leaks and correct immediately before operating vehicle.

STEP 19. Reset the oil life monitor in the DIC.

STEP 20. Over the next several cycles of vehicle operation inspect the transmission, pan, and ports for any signs of leaks and periodically check the transmission fluid level as described in steps 16 & 17.

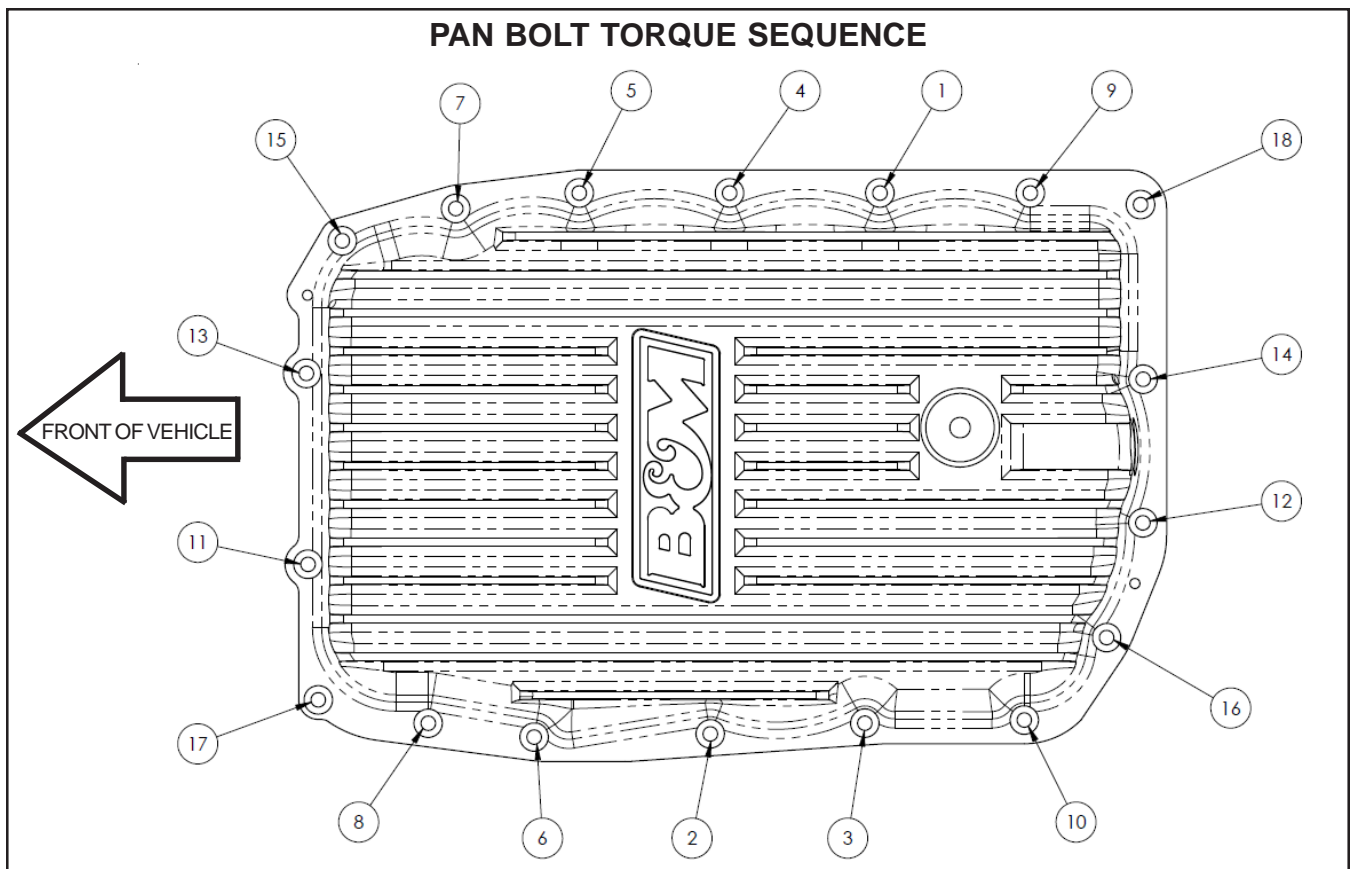

Parts List	
1	B&M Cast Alum. Pan
1	Magnetic Drain Plug
1	1/8" NPT Pipe Plug
1	M6-1.0x10mm Screw
1	Oversized Washer
18	M6-1.0x25 mm Bolts
18	M6 Flat Washers
1	Transmission Filter*
	*(not included - but recommended)

Tools List	
Drain Pan	Torque Wrench(s)
14mm Deep Socket	Clean Rags
Ratchet Extension	8 Quarts (7.6L) Dexron VI Trans Fluid
Ratchet	Jack & Jack Stands
10mm Socket	Funnel
Flat Blade Screwdriver	B&M P/N 22168-Locking Dip Stick (suggested - otherwise use:)
4mm & 3/8" Hex Wrench	Fluid Pump
5mm Hex Drive	Tubing
7/16" Box Wrench	
Teflon Tape	

Technical Service

A highly trained technical service department is maintained by B&M Racing and Performance Products to answer your technical questions, provide additional product information and offer various recommendations. B&M offers a wide variety of transmission related products to improve cooling and ultimately longevity of your transmission. See your local retailer of B&M products for specific prices.

Technical service calls, correspondence, and warranty questions should be directed to the following address:

B&M Racing and Performance Products
 100 Stony Point Rd., Ste. 125
 Santa Rosa, CA 95401
 Phone (707) 544-4761
 Monday-Friday 7AM to 5PM PST



P/N 22168

**LOCKING TRANSMISSION DIPSTICK
FOR 6L80 TRANSMISSIONS**

*(specifically designed for 2010-2014 Camaro
SS with Automatic Transmission)*

www.bmracing.com



P/N 70297

**HI-TEK ENGINE OIL & AUTOMATIC
TRANSMISSION COOLER**

*(for 2010-2014 Camaro SS with Automatic
Transmission)*

www.bmracing.com



P/N 70274

**SUPERCOOLER - TRANSMISSION OIL
COOLER**

*(for 2010-2014 Camaro SS with Automatic
Transmission)*

www.bmracing.com

