



## Installation Instructions

# ***Changeover Kit TH-200 & TH-700 to TH-350***

Part Number 30299

© B&M Automotive Products 1994

The B&M TH-200/TH-700 to TH-350 Changeover Kit was designed to simplify the installation of a TH-350 or TH-350C transmission in any 1982 through 1992 Chevrolet Camaro or Pontiac Firebird originally equipped with either a TH-200 or TH-700 transmission. This kit uses your existing transmission mount and cross member.

GM manufactured the TH-350 and TH-350C with a large variety of bellhousings and extension housings. When selecting your TH-350 or TH-350C the bellhousing and the speedometer driven gear housing bore (located in the extension housing) must match your current transmission. You will also have to purchase a detent cable and vacuum modulator that are appropriate for your application.

B&M #30287 is a fully adjustable TH-350 kickdown cable suitable for this transmission swap as well as the B&M vacuum modulator #20234.

The catalytic converter is supported by a bracket normally attached to the rear of the transmission. Because these braces differ with year and model, you will have to fabricate a suitable bracket to brace the catalytic converter.

This kit includes a torque arm mounting bracket and mounting hardware. For a TH-700 you will need to purchase one of two different torque arm outer brackets. (See Step 8.) For a TH-700 you will also need a longer drive shaft.

**NOTICE:** The TH-350 and TH-350C transmission will not necessarily interface with your vehicle's E.C.M. system. As a result your vehicle may not meet the original equipment specifications required by your state's emissions laws.

B&M also manufactures the following quality products which can enhance your TH-350 transmission conversion installation:

1. Holeshoot 2400 (#20412), Holeshoot 3000 (#20413) and Holeshoot 3600 (#20425). The B&M line of high stall speed

torque converters are designed to provide much greater acceleration from standstill, more torque at lower speeds, and smoother idle, without pulling against the brakes at stoplights as a stock torque converter will with a highly modified engine.

2. Transkits and Transpaks. B&M offers a full line of high performance transmission products for your TH-350. B&M's Transkit closely resembles a B&M street & strip transmission in a do it yourself kit. This kit contains a complete seal and gasket kit, new intermediate and direct clutch plates and steels, all necessary parts for the modifications to convert your valve body to a full B&M Manual/Automatic valve body. B&M's Transpak is the next step beyond a shift improver. Transpak offers all the features found in the shift improver kit plus provides for additional driver manual control, with this three stage kit you can select the performance mode which best suits your application. The three performance modes are as follows: RV/Heavy Duty, High Performance Street and Full Competition.

3. Trick Shift A.T.F. The first and only real performance fluid for automatic transmissions. A specially blended oil with foam inhibitor, extreme pressure agents and shift improvers, this fluid assures protection while delivering the fastest possible shifts. Conveniently available in quart bottles.

4. B&M Deep Pan. B&M offers both chrome plated stamped steel deep pans as well as premium grade cast aluminum deep pans. Deep pans provide 3 to 4 additional quarts of fluid capacity. All B&M deep pans are fitted with a built-in drain plug, an important feature for regular transmission maintenance.

5. Oil cooler. B&M transmission oil coolers extend transmission and transmission fluid life and reduce the possibility of overheating, the major cause of transmission failure. Coolers come complete with mounting hardware and high grade hose

for fast easy installation. B&M highly recommends the installation of an oil cooler on all high performance applications.

6. Megashifter (#80692) for 1982-92 Camaro and Firebird. The Megashifter is capable of ratcheting to any position on the quadrant from first to neutral.

### PREPARATION

Before proceeding with the installation READ THE INSTRUCTIONS THOROUGHLY particularly the PARTS REQUIRED list for your application. For an efficient installation make sure you have all of the required components to complete the job before you begin. Note: Hardware used on the TH-200 and TH-700 is METRIC, while the TH-350 is INCH and the TH-350C uses both INCH and METRIC hardware. Equipment rental yards are a good source for transmission jacks and jack stands if you do not have them available.

**STEP 1.** Raise and SECURELY support the vehicle. Drain transmission oil pan. Remove drive shaft taking care to wrap a piece of tape around the rear universal joint bearings to keep them clean and on the journals.

**STEP 2.** Disconnect or remove the following:

**A.** Disconnect the cooler lines located on the right side of the transmission. Use a fitting wrench to avoid damaging the tube fittings. We recommend flushing the cooler lines to remove any foreign matter that may be trapped in the cooler. Cooler lines should be flushed in both directions with clean solvent and compressed air (wear eye protection whenever using solvent and/or compressed air.)

**B.** Disconnect the throttle valve cable from the carburetor and manifold bracket, then carefully pull the cable to the bottom of the car.

**C.** Remove the shift lever and cable bracket.

**D.** Remove outer torque arm bracket.

**E.** Remove the catalytic converter bracket from the rear of the transmission. Because these braces differ with year and model, you will have to fabricate a suitable bracket to brace the catalytic converter.

**F.** Disconnect the speedometer cable and electrical connector from the left side of the transmission.

**STEP 3.** Remove the torque converter splash shield, then, remove the flexplate to converter bolts. Use the starter to "bump" (disconnect coil wire before trying this) each bolt into position.

**STEP 4.** Remove the distributor cap to prevent damage while lowering transmission. Place transmission jack in position and take weight off lower transmission support. Remove lower transmission support, upper transmission support and transmission mount, then lower transmission enough to remove the dip stick lube and bellhousing bolts. Make sure all connections are removed, then lower and pull transmission/torque converter away from engine. Exercise extreme caution while handling transmission/converter as it is heavy and difficult to handle under the vehicle.

**STEP 5.** Inspect engine block and flexplate. Remove any dirt or burrs that would prevent transmission from bolting up flat against the engine block. The dowel pins should protrude at least 1/2" from surface of block to insure proper transmission alignment. Check flexplate for distortion, cracks or elongated bolt holes. Check ring gear for excessively worn or missing gear teeth. Check for loose or missing flexplate to crankshaft bolts.

**STEP 6.** Install TH-350 torque converter on crankshaft to insure the torque converter's hub fits into the crankshaft pilot

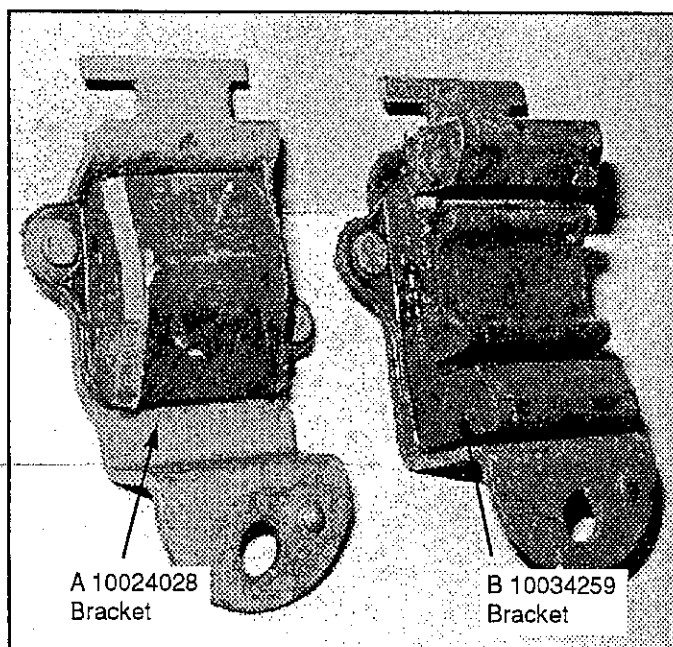

Figure 1A

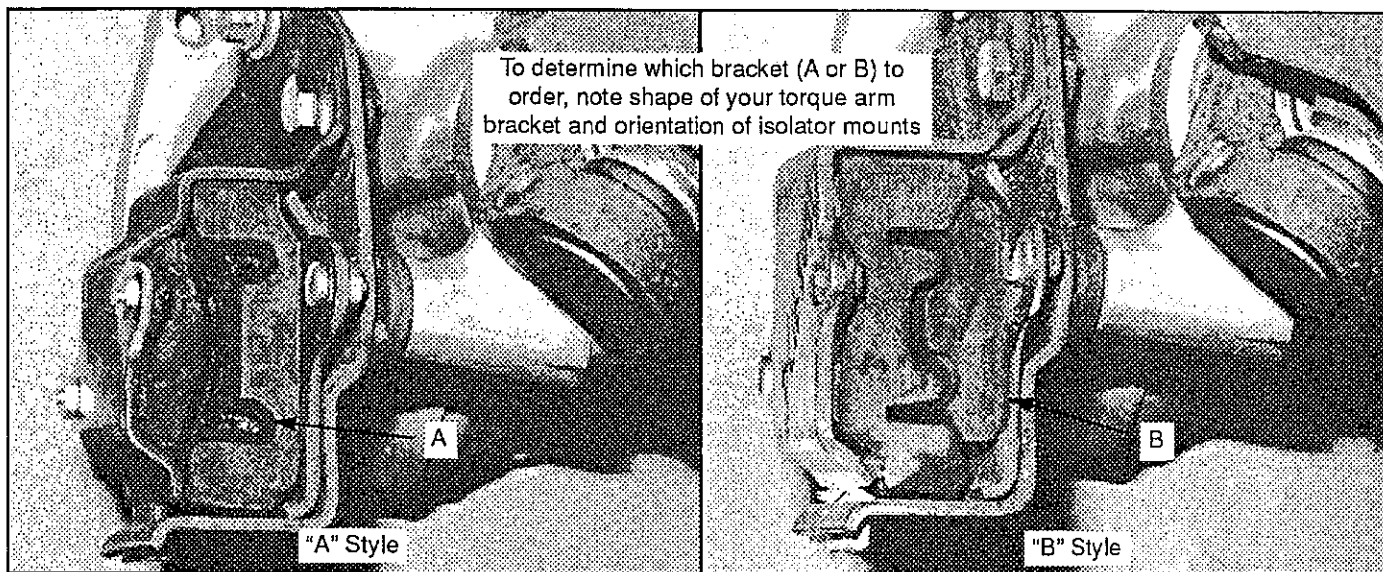

Figure 1B

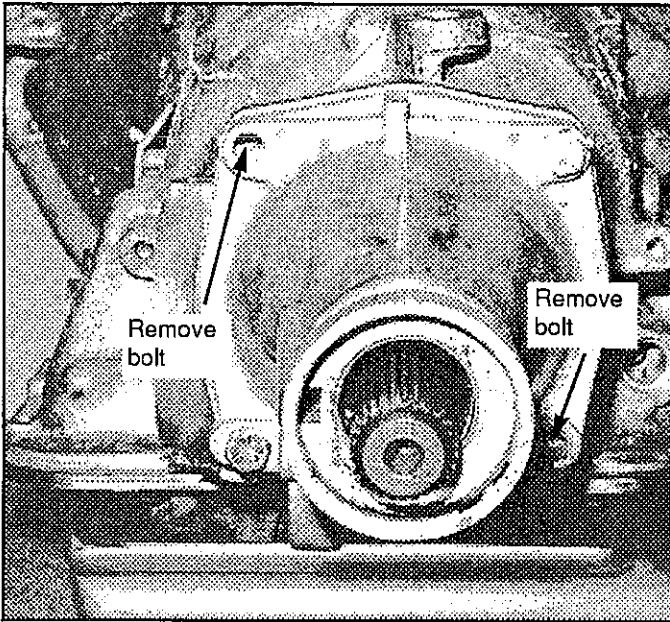

Figure 2

bore snugly without excessive clearance. With the torque converter's hub pressed firmly against the crankshaft a gap of 1/16" to 1/8" should exist between the flexplate and the torque converter's drive lugs. When the drive bolts are installed the flexplate will bow rearward and hold the torque converter against the crankshaft (do not install bolts at this time.)

**STEP 7.** Torque arm inner bracket installation. Remove two extension housing bolts shown in Fig. 2. Install two (2) 3/8"-16 x 1 5/8" bolts where shown as a check to see if the bolts bottom out before the head makes contact. The objective is to obtain a gap between the bolt's head and extension housing of 1/8" or less (Fig. 3), this will insure maximum thread engagement when the inner torque arm bracket is installed. If necessary, tap the case threads deeper with a 3/8"-16 tap rather than shortening the bolts. Remove extension housing (This is a good time to swap speedometer gears if you have not already done so), and thread the short threaded end of supplied stud in lower left hand case hole (See Fig. 4). Use two nuts wrenched together on opposite end of stud to drive stud in. Install the B&M inner torque arm bracket as shown (Fig. 5 or

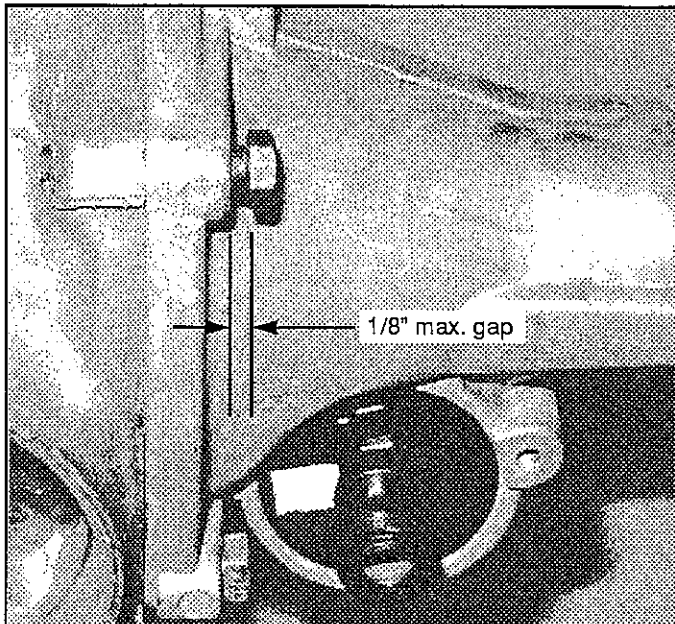

Figure 3

6) using split lock washers under nut and bolt heads. Torque extension housing to case fasteners to 35 ft.-lbs. (48 Nm.).

**Step 8.** Assembling torque arm insulator mounts.

**A.** TH-200 Applications. Remove the insulator mount from inner torque arm support bracket and attach it to the B&M torque arm bracket in the position shown in Fig. 5. You will reuse the stock outer bracket and isolator.

**B.** TH-700 Applications. Refer to Fig. 1B to determine which style outer torque arm bracket you have, "A" or "B". The outer arm brackets are not interchangeable because of the isolator's shape. Once you have determined which outer bracket is required, Order the GM part number shown in Fig. 1A (GM #10024028 for type "A" or GM #10034259 for type "B"). Remove the isolator mount from the inner torque arm mount and attach it to the B&M torque arm mount in the position shown in Fig. 6. The new GM outer bracket comes with the isolator mount already attached.

**STEP 9.** Remove oil pan and install detent cable (if required). Clean all old gasket material from pan and case, re-install pan with new gasket (not supplied) and torque pan bolts to 13 ft.-lbs. To prevent damage to the gasket do not overtighten pan bolts.

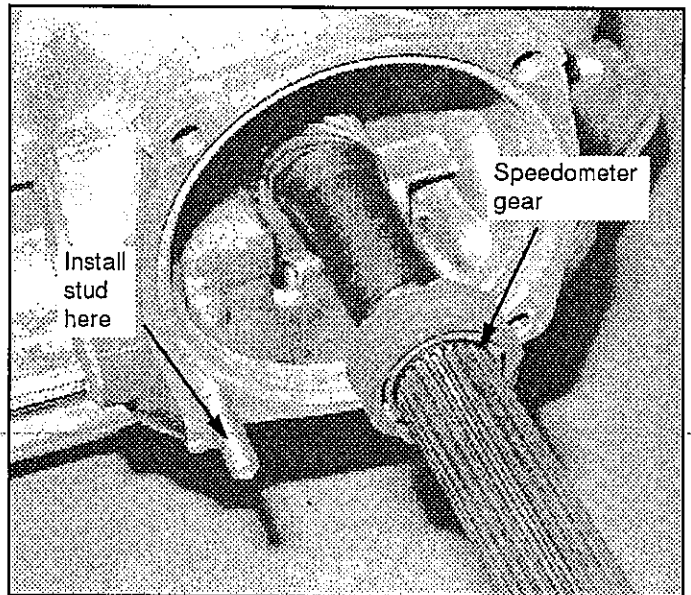

Figure 4

**STEP 10.** Lubricate the torque converter pump drive tube with clean ATF then carefully guide the torque converter over the input shaft onto transmission. Gently push and rotate the torque converter to engage the input shaft, reaction shaft and oil pump rotor drive tangs. Using a straight edge placed across the bell housing face, make sure the drive lug faces are at least 1" inside the bellhousing surface. A measurement of less than 1" indicates the torque converter is not fully engaged, continue to push and turn the torque converter until fully engaged. If the transmission is installed without full torque converter engagement the torque converter and oil pump will be damaged.

**STEP 11.** Using transmission jack install transmission assembly against engine block. The transmission should engage the dowel pins and sit flat against the block with hand pressure only. If the transmission does not sit flat against the block then either the torque converter is not fully engaged or some other interference problem exists. Do not attempt to pull the transmission up against the block with the bellhousing bolts as this will damage the transmission or torque converter, the transmission must engage freely. With the transmission properly located install bellhousing bolts and torque to 35 ft.-lbs. (48 Nm.).

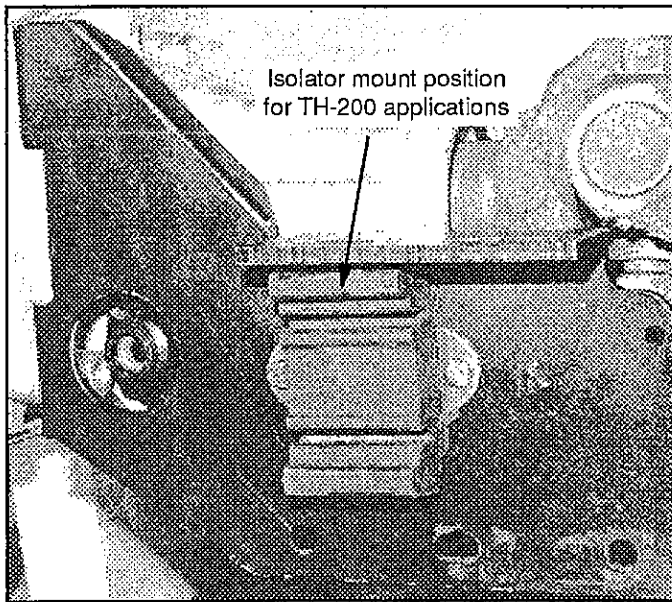

Figure 5

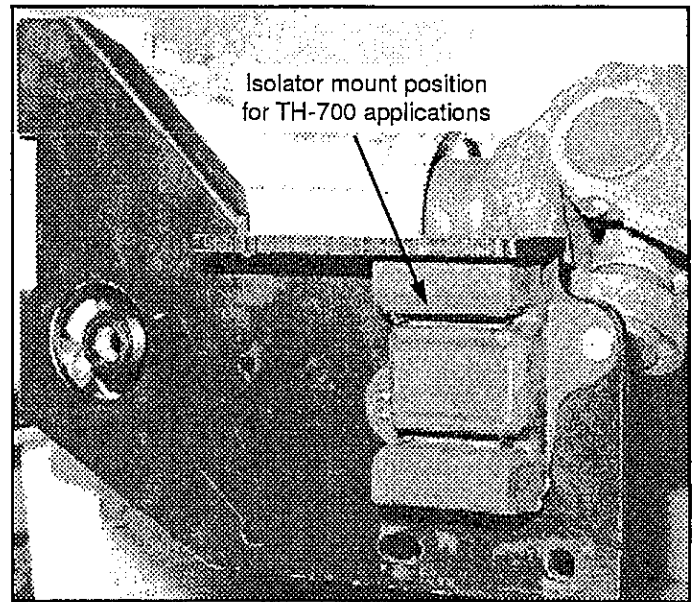

Figure 6

**STEP 12.** Install the TH-350 dip stick tube and tube seal. Connect TH-350 detent cable to carburetor and manifold bracket. Install the vacuum modulator and connect it to intake manifold with 7/32" ID hose. Assemble outer torque arm bracket into appropriate slot on inner torque arm bracket, do not install bolts at this time.

**STEP 13.** Install transmission crossmember and mount assembly.

**A. TH-200 installations.** Install transmission mount and upper transmission support, raise transmission high enough to install lower transmission support to frame. Sandwich torque arm between inner and outer torque arm brackets making sure the isolator mounts match the shape of torque arm, then bolt inner and outer brackets together. Install lower transmission support to frame then remove transmission jack and finish support installation.

**B. TH-700 installations.** Bolt the supplied mount adapter to the transmission mount holes on the TH-350 transmission as shown in Fig. 7. The two welded in studs should point down and be towards the rear of the vehicle. Install transmission mount to the two studs with flat washers, lock washers and nuts, Install the upper transmission support, raise transmission high enough to install lower transmission support to frame. Sandwich torque arm between inner and outer torque arm brackets making sure the isolator mounts match the shape of torque arm, then bolt inner and outer brackets together. Install lower transmission support to frame then remove transmission jack and finish support installation.

**STEP 14.** Install driveshaft. For TH-200 installations use the original drive shaft. For TH-700 installations you may need to have your drive shaft lengthened or replace it with GM #7840541. *N/A*

**STEP 15.** Re-connect oil cooler lines to transmission. Lubricate drive shaft slip yoke with clean ATF and install drive shaft. Install catalytic converter support bracket (fabricate as required).

**STEP 16.** Shifter connections:

**A.** Vehicle originally equipped with TH-200. You can reuse the stock shift lever and cable bracket. The shifter will work the same as before the swap.

**B.** Vehicle originally equipped with TH-700. You can reuse the stock shift lever and cable bracket. The shifter will work the same as before the swap with two EXCEPTIONS: The indi-

cated forward gears moved up one gear, i.e. O.D.=D, 3=2, 2=1, and the shifter will not shift to the 1" position.

**STEP 17.** Check complete installation for omitted steps and loose or missing fasteners or components. Replace distributor cap and coil wire. Fill transmission with clean ATF. Start engine and check fluid level. Check transmission for oil around converter area, oil pan flange, vacuum modulator, dip stick, detent cable and servo cover.

**STEP 18.** Lower vehicle and test drive.

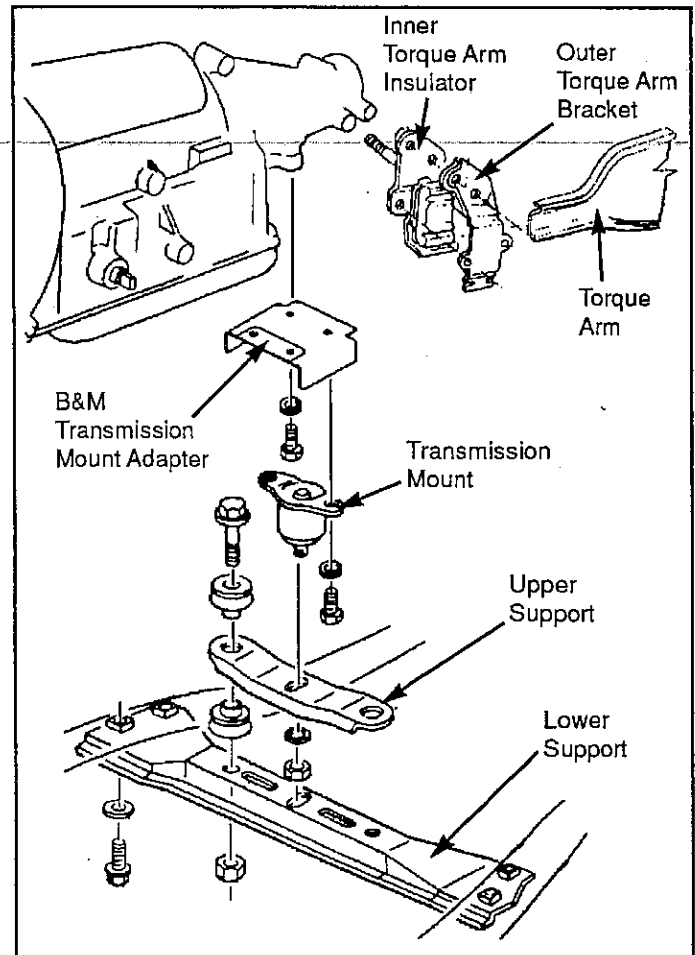

Figure 7