

Installation for Cadillac CTS-V Coupe PN -12662**



These instructions have been written to help you with the installation of your Borla Performance Exhaust System. Please read this document completely before beginning the installation of your system.

Please compare the parts in the box with the bill of materials provided to assure that you have all the parts necessary for this installation.

To ensure this part number fits your specific model year, please visit our website for the latest model year listings at www.BORLA.com.

Thank you for purchasing a Borla Performance Exhaust System.

Borla Performance Exhaust System (PN-12662) is designed for the Cadillac CTS-V Coupe equipped with a 6.2L engine, rear-wheel drive with automatic or manual transmissions.

****THIS SYSTEM HAS BEEN DEVELOPED FOR RACING USE ONLY. NOT LEGAL FOR USE ON PUBLIC ROADS OR HIGHWAYS.****

Borla Performance Industries recommends that an exhaust shop or professional after market parts installer perform the installation of this system. However, if you decide to perform the installation on your own it is recommended that two people are used. This installation should not be performed by one person due to the risk of injury. Ensure the installers use all under car safety precautions including eye protection.

Please take time to read and understand the following...

By installing your Borla Performance Exhaust System, you indicate that you have read this document and you agree with the terms stated below.

It is the responsibility of the purchaser to follow all installation instruction guidelines and safety procedures supplied with your Borla Performance Exhaust System

Borla Performance Industries assumes no responsibility for damages occurring from misuse, abuse, improper installation, improper operation, lack of responsible care, or all previously stated reasons resulting from incompatibility with other manufacturer's products and/or systems.

Included with your Borla Performance Exhaust System is a warranty card. Please read it carefully before you begin any work on your vehicle. If you should have any questions regarding our warranty policy, installation, or any other matter pertaining to your new Borla Performance Exhaust System, please give us a call at the number provided on the warranty card.

****THIS SYSTEM HAS BEEN DEVELOPED FOR RACING USE ONLY. NOT LEGAL FOR USE ON PUBLIC ROADS OR HIGHWAYS. ****

Minimum Required Tool List:

TOOLS:

- 1 3/8" Drive Ratchet
- 2 3/8" Drive Extension 3"
- 3 15mm Deep Well Socket
- 4 Pry Bar
- 5 Metal-cutting Sawsall

SHOP SUPPLIES:

- 1 Spray Lubricant

Borla Performance Bill of Materials

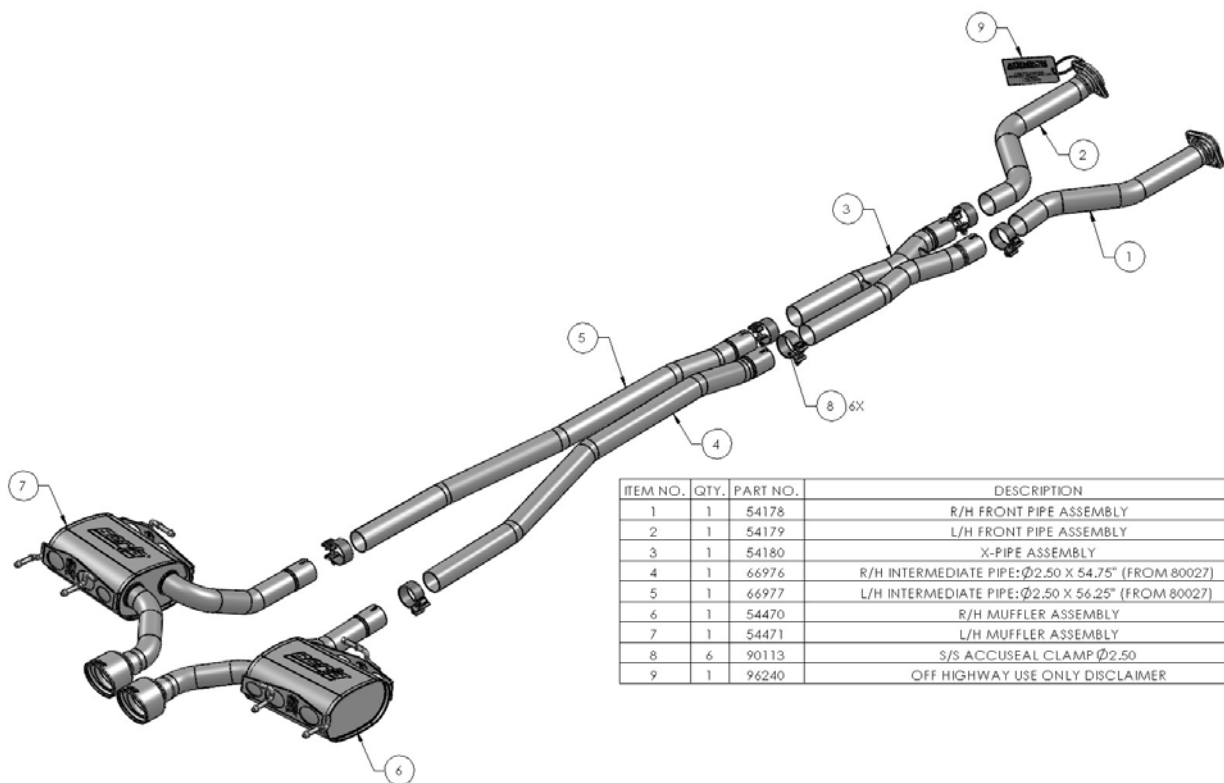

ITEM NO.	QTY.	PART NO.	DESCRIPTION
1	1	54178	R/H FRONT PIPE ASSEMBLY
2	1	54179	L/H FRONT PIPE ASSEMBLY
3	1	54180	X-PIPE ASSEMBLY
4	1	66976	R/H INTERMEDIATE PIPE: Ø2.50 X 54.75" (FROM 80027)
5	1	66977	L/H INTERMEDIATE PIPE: Ø2.50 X 56.25" (FROM 80027)
6	1	54470	R/H MUFFLER ASSEMBLY
7	1	54471	L/H MUFFLER ASSEMBLY
8	6	90113	S/S ACCUSEAL CLAMP Ø2.50
9	1	96240	OFF HIGHWAY USE ONLY DISCLAIMER

Caution!!! Never work on a hot exhaust system. Serious injury in the form of burns can result If the vehicle has been in use and the exhaust system is hot, allow vehicle to cool for at least 1 hour. Always wear eye protection when working under any vehicle.

Note: It is our recommendation that you use a hoist or hydraulic lift to facilitate the installation of your new Borla Performance Exhaust System.

Taking all under car safety precautions, lift the vehicle using a hoist or hydraulic lift. Once this has been done, you may begin the removal of your old exhaust system from your vehicle.

Note: Before removing the original exhaust system from your vehicle, please compare the parts you have received with the bill of materials provided on the previous page to assure that you have all the parts necessary for the installation of your new Borla Performance Exhaust System.

****THIS SYSTEM HAS BEEN DEVELOPED FOR RACING USE ONLY. NOT LEGAL FOR USE ON PUBLIC ROADS OR HIGHWAYS.****

Original Exhaust System Removal

Note: With a used vehicle, we suggest a penetrating spray lubricant to be applied liberally to all exhaust fasteners and allowing a significant period of time for the chemical to lubricate the threads before attempting to disassemble.

1. Remove (2) bolts and crossbar. Place this hardware aside for installation later. (See Fig. 1)
2. Unbolt (4) front flange bolts and put aside for installation later. (See Fig.2)
3. Support the exhaust system using muffler stands. Carefully remove muffler hangers from rubber isolators and remove OE exhaust system. (See Figs. 3 & 4)

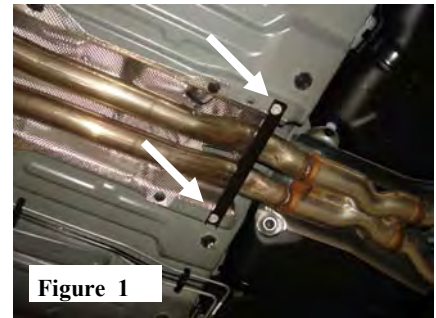

Figure 1



Figure 2



Figure 3



Figure 4

Warning: Use extreme caution during installation. Torque all fasteners according to manufacturer's torque values and tightening sequence. DO NOT use air impact tools to tighten fasteners on Borla Performance Exhaust Systems. Use of such tools may result in bent flanges or gasket contact areas leading to exhaust leaks.

****THIS SYSTEM HAS BEEN DEVELOPED FOR RACING USE ONLY. NOT LEGAL FOR USE ON PUBLIC ROADS OR HIGHWAYS.****

Borla Performance System Installation

1. Read and remove Off Highway Use Only Disclaimer on L/H Front Pipe Assembly.
2. Attach both Front Pipe Assemblies using original hardware.
3. Place a clamp over both inlet pipes of X-Pipe Assembly and slide over both Front Pipe Assembly outlets. pipe. Insert hangers into the original rubber isolators. DO NOT TIGHTEN CLAMPS(See Fig.3)
4. Place a clamp over each outlet of X-Pipe. Starting with L/H Intermediate Pipe, insert inlet into X-pipe making sure to support pipe. Repeat for R/H Intermediate Pipe. DO NOT TIGHTEN CLAMPS.
5. Place a clamp over outlet of each outlet of Intermediate Pipe. Starting with L/H Muffler Assembly insert inlet into L/H Intermediate Pipe and insert hangers into factory rubber isolators. Repeat for R/H Muffler Assembly. DO NOT TIGHTEN CLAMPS.(See Fig.4)
6. Check your exhaust system for proper clearance under the vehicle and also for tip alignment. Once tip position has been determined to be correct, position clamps making sure the bolt is positioned between the pipe notch. (See Figs. 5,6 & 7)
7. Tighten clamp bolts to 35 lb.ft. torque. Tighten (4) flange bolts. Reinstall cross-brace using factory hardware.
8. Before starting your vehicle, make sure to check all wires, hoses, brake lines, body parts and tires for safe clearance from the exhaust system.
9. Start vehicle and check for any leaks. If any leaks are found, determine cause (such as loose hardware or incorrectly positioned clamp) and repair as necessary.

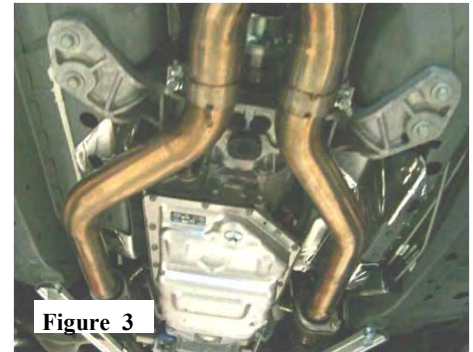

Figure 3

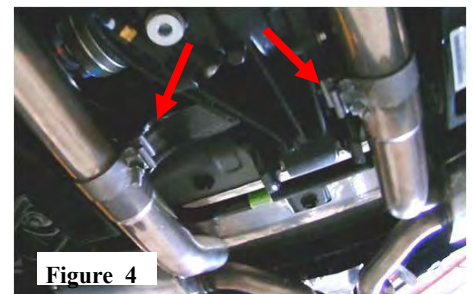

Figure 4



Figure 5

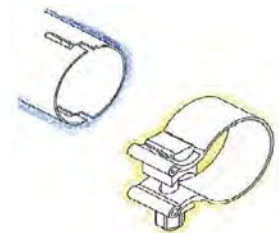

Figure 6

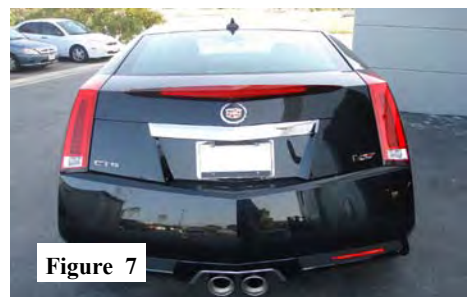

Figure 7

Note: When you first start your vehicle after the installation of your new Borla Performance Exhaust System, there may be some smoke and fumes coming from the system. This is a protective oil based coating used in the manufacturing of mandrel bent performance exhaust tubing. This is not a problem and will disappear within a very short period of time after the exhaust has reached normal operating temperatures.