

Exhaust System Installation For 2007 Maserati Quattroporte



Precision manufactured using high quality austenitic stainless steel; this system is designed to endure years of heavy use. Installing a Borla Performance Exhaust System on your vehicle will eliminate the restrictive design of the stock exhaust, allowing your engine to discharge exhaust gas easier. The result is more horsepower and torque, longer engine life, and a distinctive throaty growl- all this, with easy bolt-on installation. These installation instructions have been written to help you in the installation of your Borla Performance Exhaust System. Please read it completely before installing your system.

Thank you for purchasing a Borla Performance Cat-Back™ Exhaust System.

This Borla Performance Cat-Back™ Exhaust System (Part number 140288) has been designed for the 2007 Maserati Quattroporte equipped with a 4.2L V8 engine and an automatic transmission.

Borla Performance Industries recommends that an exhaust shop or professional after market parts installer, who has all the necessary equipment, tools and experienced personnel needed for proper installation, should perform the installation of this system. However, if you decide to perform the installation, we recommend someone should help you. Ensure the installer uses all under car safety precautions including eye protection.

Please take time to read and understand the following...

By installing your Borla Performance Cat-Back™ Exhaust System, you indicate that you have read this document and you agree with the terms stated below.

It is the responsibility of the purchaser to follow all installation instruction guidelines and safety procedures supplied with your Borla Performance Cat-Back™ Exhaust System.

Borla Performance Industries assumes no responsibility for damages occurring from misuse, abuse, improper installation, improper operation, lack of responsible care, or all previously stated reasons resulting from incompatibility with other manufacturer's products and/or systems.

Included with your Borla Performance Cat-Back™ Exhaust System is a warranty card. Please read it carefully before you begin any work on your vehicle. If you should have any questions regarding our warranty policy, installation, or any other matter pertaining to your new Borla Performance Cat-Back™ Exhaust System, please give us a call at the number provided on the warranty card.

Minimum Required Tool List:**TOOLS:**

- 1 3/8" Drive Ratchet
- 2 3/8" Drive Extension 3"
- 3 15mm Socket
- 4 13mm Socket
- 5 Pry Bar

SHOP SUPPLIES:

- 1 Spray Lubricant

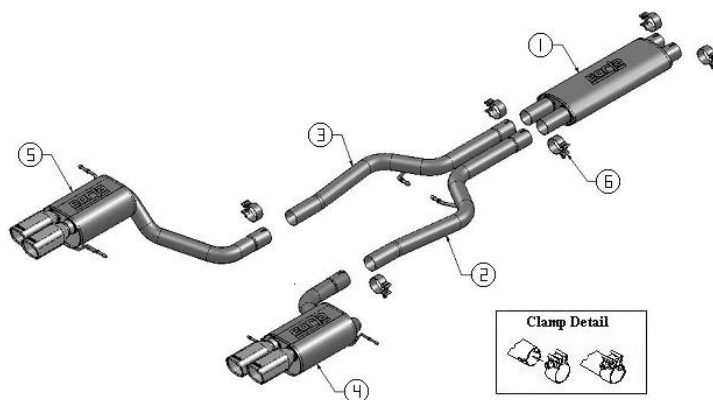
Borla Performance Cat-Back™ Bill of Materials

1. Front muffler assembly
2. R/H intermediate pipe assembly
3. L/H intermediate pipe assembly
4. R/H rear muffler assembly
5. L/H rear muffler assembly
6. 2.50" clamp (qty 6)

Caution!!! *Never work on a hot exhaust system. Serious injury in the form of burns can result* If the vehicle has been in use and the exhaust system is hot, allow vehicle to cool for at least 1 hour. Always wear eye protection when working under any vehicle.

Note: It is our recommendation that you use a hoist or hydraulic lift to facilitate the installation of your new Borla Performance Cat-Back™ Exhaust System.

Taking all under car safety precautions, lift the vehicle using a hoist or hydraulic lift. Once this has been done, you may begin the removal of your original exhaust system from your vehicle.

Note: Before removing the original exhaust system from your vehicle, please compare the parts you have received with the bill of materials provided on the previous page to assure that you have all the parts necessary for the installation of your new Borla Performance Cat-Back™ Exhaust System.

Original Exhaust System Removal

Note: With a used vehicle, we suggest a penetrating spray lubricant to be applied liberally to all exhaust fasteners and allowing a significant period of time for the chemical to lubricate the threads before attempting to disassemble.

1. Unbolt and remove the bracket shown in figure 1 located in front of the rear muffler assemblies.
2. Loosen the clamps also shown in figure 1 located just in front of the cross bracket.
3. Lubricate all hangers and rubber isolators.
4. Beginning with the left (driver) side and using a muffler stand or an additional person to hold the rear muffler assembly up into position, unbolt the front and back hanger bracket isolators shown in figure 2 and remove the rear muffler assembly from the vehicle. Place hardware to the side.
5. Remove the bracket isolators shown in figure 2 from the muffler assembly and using the original hardware install them back to their original location.
6. Repeat steps 4 and 5 for the removal of the right (passenger) side rear muffler assembly.
7. Loosen the clamps located just behind the factory x-pipe assembly.
8. Remove the hangers from the rubber isolators and remove the left and right intermediate pipes from the vehicle as shown in figure 3.
9. Loosen the clamps located just ahead of the front muffler assembly and remove the muffler from the vehicle as shown in figure 4.



Figure 1

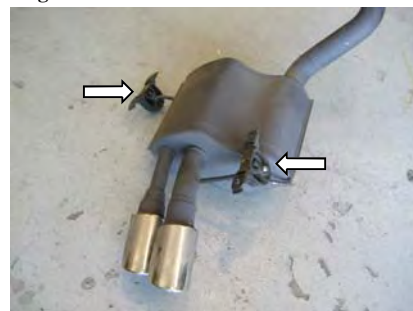

Figure 2



Figure 3



Figure 4

Warning: Use extreme caution during installation. Torque all fasteners according to manufacturer's torque values and tightening sequence. **DO NOT** use air impact tools to tighten fasteners on Borla Performance Exhaust Systems. Use of such tools may result in bent flanges or gasket contact areas leading to exhaust leaks.

Borla Performance Cat-Back™ Exhaust System Installation

1. Place the clamps provided over the expanded ends of the front muffler assembly and set it up into position as shown in figure 5. Do Not tighten the clamps.
2. Place a clamp provided over the expanded end of the left (driver side) and right (passenger) side intermediate pipe assemblies and set them up into position as shown in figure 6. Making sure to install the hangers into the rubber isolators Do Not tighten the clamps.
3. Place a clamp provided over the expanded end of the left (driver) and right (passenger) side rear muffler assemblies and set them up into position as shown in figure 7 making sure to install the hangers into the rubber isolators. Do Not tighten the clamps.
4. Check your exhaust system for proper clearance under the vehicle and also for tip alignment.
5. Once position has been determined to be correct, tighten the Accuseal™ clamps to 32-35 ft. lbs making sure the clamp opening is not over any of the notches.
7. Before starting your vehicle, make sure to check all wires, hoses, brake lines, body parts and tires for safe clearance from the exhaust system.
8. Start vehicle and check for any leaks. If any leaks are found, determine cause (such as loose or incorrectly positioned clamp) and repair as necessary.

Note: When you first start your vehicle after the installation of your new Borla Performance Exhaust System, there may be some smoke and fumes coming from the system. This is a protective oil based coating used in the manufacturing of mandrel bent performance exhaust tubing. This is not a problem and will disappear within a very short period of time after the exhaust has reached normal operating temperatures.



Figure 5



Figure 6



Figure 7