

Exhaust System Installation For 2008/2009 SmartCar ForTwo



Precision manufactured using high quality austenitic stainless steel; this system is designed to endure years of heavy use. Installing a Borla Performance Exhaust System on your vehicle will eliminate the restrictive design of the stock exhaust, allowing your engine to discharge exhaust gas easier. The result is more horsepower and torque, longer engine life, and a distinctive throaty growl- all this, with easy bolt-on installation. These installation instructions have been written to help you in the installation of your Borla Performance Exhaust System. Please read it completely before installing your system.

Thank you for purchasing a Borla Performance Cat-Back™ Exhaust System.

Borla Performance Cat-Back™ Exhaust System (part number 140311) has been designed for the 2008/2009 SmartCar ForTwo Hatchback equipped with a 1.3L 3-cylinder engine, rear-wheel drive and automatic transmission.

Borla Performance Industries recommends that an exhaust shop or professional after market parts installer, who has all the necessary equipment, tools and experienced personnel needed for proper installation, should perform the installation of this system. However, if you decide to perform the installation, we recommend someone should help you. Ensure the installer uses all under car safety precautions including eye protection.

Please take time to read and understand the following...

By installing your Borla Performance Exhaust System, you indicate that you have read this document and you agree with the terms stated below.

It is the responsibility of the purchaser to follow all installation instruction guidelines and safety procedures supplied with your Borla Performance Exhaust System

Borla Performance Industries assumes no responsibility for damages occurring from misuse, abuse, improper installation, improper operation, lack of responsible care, or all previously stated reasons resulting from incompatibility with other manufacturer's products and/or systems.

Included with your Borla Performance Exhaust System is a warranty card. Please read it carefully before you begin any work on your vehicle. If you should have any questions regarding our warranty policy, installation, or any other matter pertaining to your new Borla Performance Exhaust System, please give us a call at the number provided on the warranty card.

Minimum Required Tool List:

TOOLS:

1. 3/8" Drive Ratchet
2. 3/8" Drive Extension 3"
3. 10mm Socket
4. Torx socket
5. Pry Bar

SHOP SUPPLIES:

- 1 Spray Lubricant

Borla Performance Cat-back™ Bill of Materials

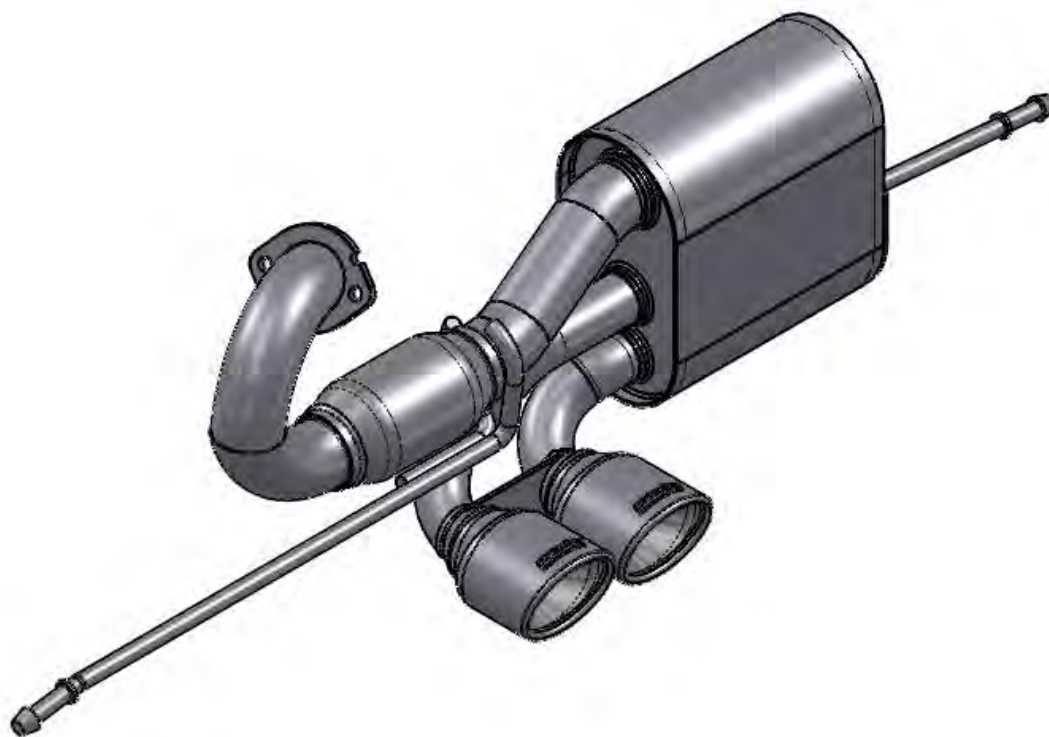

1. Muffler assembly

Caution!!! Never work on a hot exhaust system. Serious injury in the form of burns can result! If the vehicle has been in use and the exhaust system is hot, allow vehicle to cool for at least 1 hour. Always wear eye protection when working under any vehicle.

Note: It is our recommendation that you use a hoist or hydraulic lift to facilitate the installation of your new Borla Performance Rear Section Exhaust System.

Taking all under car safety precautions, lift the vehicle using a hoist or hydraulic lift. Once this has been done, you may begin the removal of your old exhaust system from your vehicle.

Note: Before removing the original exhaust system from your vehicle, please compare the parts you have received with the bill of materials provided on the previous page to assure that you have all the parts necessary for the installation of your new Borla Performance Rear Section Exhaust System.

Original Exhaust System Removal

Note: With a used vehicle, we suggest a penetrating spray lubricant to be applied liberally to all exhaust fasteners and allowing a significant period of time for the chemical to lubricate the threads before attempting to disassemble.

1. Remove rear valance with (2) torx screws (figure 1) and (2) reusable clips on firewall. Put hardware aside. Carefully remove rear valance (figure 2).
2. Lubricate all the hangers and rubber isolators.
3. Using a muffler stand or an additional person to hold the rear muffler into position, remove the hangers from the rubber isolators and remove the rear muffler from the vehicle.
4. Unbolt the flange (2-bolts) as shown located just behind the catalytic converter (figure 3). Place the hardware to the side for use during the installation of your new exhaust system.
5. Using a muffler stand or an additional person to hold the front muffler assembly into position, remove the hangers from the rubber isolators and remove the muffler from the vehicle (figure 4).

Warning: Use extreme caution during installation. Torque all fasteners according to manufacturer's torque values and tightening sequence. DO NOT use air impact tools to tighten fasteners on Borla Performance Exhaust Systems. Use of such tools may result in bent flanges or gasket contact areas leading to exhaust leaks.



Figure 1



Figure 2



Figure 3

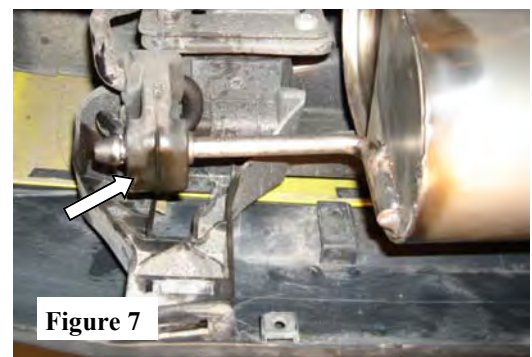

Figure 4

Borla Performance Cat-Back™ Exhaust System Installation

1. Create cut-out in valance. Place valance face-up on flat work-space. Carefully measure side-to-side and mark a vertical center-line. Position (included) template on valance and align (figure 4).
2. Using a cutting saw cut inside of line leaving 1/16" material for trimming (figure 5). Use a sanding wheel and carefully remove material to the marked line (figure 6). Hand-finish sanding for best results.
3. Install muffler by inserting hangers into (2) rubber isolators (figure 7). Bolt muffler flange using original bolts. Reinstall rear valance.
4. Check your exhaust system for proper clearance under the vehicle and also for tip alignment (figure 8).
5. Once position has been determined to be correct, tighten the flange hardware to 18-22 ft. lbs
6. Before starting your vehicle, make sure to check all wires, hoses, brake lines, body parts and tires for safe clearance from the exhaust system.
7. Start vehicle and check for any leaks. If any leaks are found, determine cause (such as loose hardware or incorrectly positioned clamp) and repair as necessary.

Note: When you first start your vehicle after the installation of your new Borla Performance Exhaust System, there may be some smoke and fumes coming from the system. This is a protective oil based coating used in the manufacturing of mandrel bent performance exhaust tubing. This is not a problem and will disappear within a very short period of time after the exhaust has reached normal operating temperatures.

**Figure 4****Figure 5****Figure 6****Figure 7****Figure 8**