



Thank you for purchasing a Borla Performance Down-Pipe.

This Down-Pipe has been designed for use only with a Borla Performance Cat-Back™ Exhaust System. Replacement down-pipes are designed exclusively for farm, line inspection off-highway and competition vehicles where the use of a catalytic converter is a fire hazard and are prohibited from being driven on public or publicly funded roads.

Precision manufactured using aircraft quality T-304 stainless steel; this down pipe is designed to endure years of heavy use. Installing a Borla Performance down pipe on your vehicle will eliminate the restrictive design of the stock down pipe, allowing your engine to discharge exhaust gas easier. The result is more horsepower and torque, longer engine life, and a distinctive throaty growl- all this, with easy bolt-on installation. These installation instructions have been written to help you in the installation of your Borla Performance down pipe. Please read it completely before installing your system.

This Borla Performance Down-Pipe (Part number 60077) has been designed for 2003-2004 Ford F250 and F350 crew cab, long bed equipped with a 6.0 V8 Power stroke turbo diesel engine and automatic or manual transmissions.

<p>Borla Performance Industries recommends that an exhaust shop or professional after market parts installer, who has all the necessary equipment, tools and experienced personnel needed for proper installation, should perform the installation of this system. However, if you decide to perform the installation, we recommend someone should help you. Ensure the installer uses all under car safety precautions including eye protection.</p>

Please take time to read and understand the following...

By installing your Borla Performance down pipe, you indicate that you have read this document and you agree with the terms stated below.

It is the responsibility of the purchaser to follow all installation instruction guidelines and safety procedures supplied with your Borla Performance down pipe.

Borla Performance Industries assumes no responsibility for damages occurring from misuse, abuse, improper installation, improper operation, lack of responsible care, or all previously stated reasons resulting from incompatibility with other manufacturer's products and/or systems.

Included with your Borla Performance down pipe is a warranty card. Please read it carefully before you begin any work on your vehicle. If you should have any questions regarding our warranty policy, installation, or any other matter pertaining to your new Borla Performance down pipe, please give us a call at the number provided on the warranty card.

Borla Performance Down-Pipe Bill of Materials

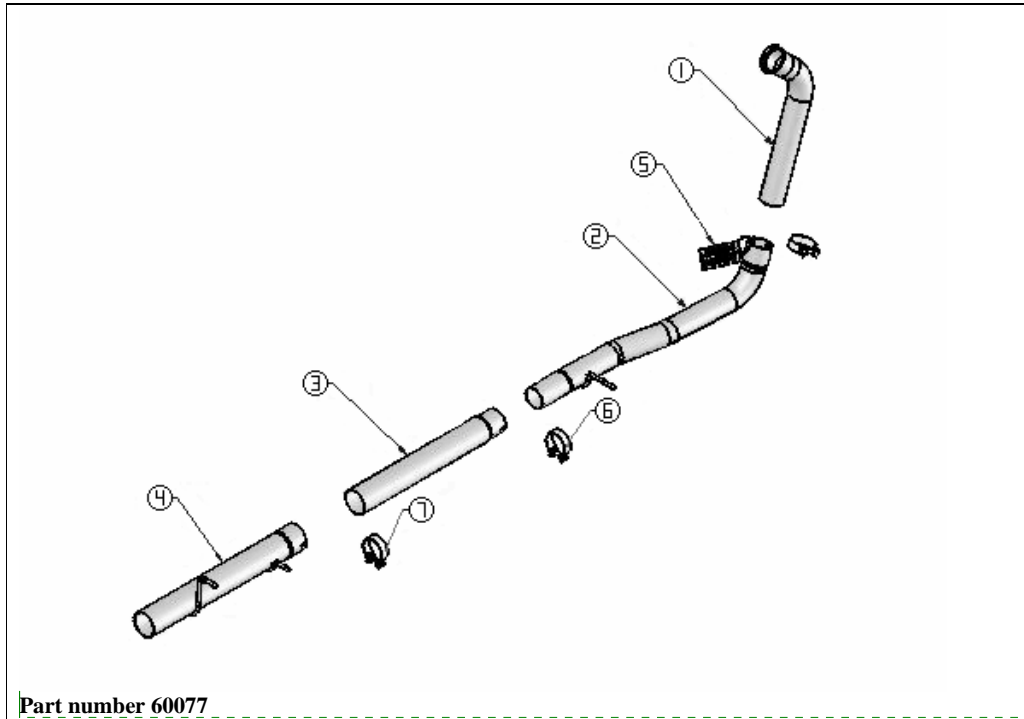

1. Upper down pipe
2. Lower down pipe
3. Front extension pipe
4. Rear extension pipe
5. Pollution control tag
6. 3.50" Accuseal™ clamp (qty 2)
7. 4.00" Accuseal™ clamp

Caution!!! Never work on a hot exhaust system. Serious injury in the form of burns can result If the vehicle has been in use and the exhaust system is hot, allow vehicle to cool for at least 1 hour. Always wear eye protection when working under any vehicle.

Note: It is our recommendation that you use a hoist or hydraulic lift to facilitate the installation of your new Borla Performance down-pipe.

Taking all under car safety precautions, lift the vehicle using a hoist or hydraulic lift. Once this has been done, you may begin the removal of your old exhaust system from your vehicle.

Note: Before removing the original exhaust system from your vehicle, please compare the parts you have received with the bill of materials provided on the previous page to assure that you have all the parts necessary for the installation of your new Borla Performance down-pipe.

Original Exhaust System Removal

Note: With a used vehicle, we suggest a penetrating spray lubricant to be applied liberally to all exhaust fasteners and allowing a significant period of time for the chemical to lubricate the threads before attempting to disassemble.

1. Disconnect the vehicle's battery.
2. Following the vehicle manufacturer's recommendations, remove the spare tire from vehicle.
3. Loosen the clamp shown in figure 1 located just after the catalytic converter.
4. Lubricate all hangers and rubber brackets.
5. Using a muffler stand or an additional person to hold the exhaust up in place, remove the hangers from the rubber brackets and remove the exhaust system shown in figure 2 from the vehicle.

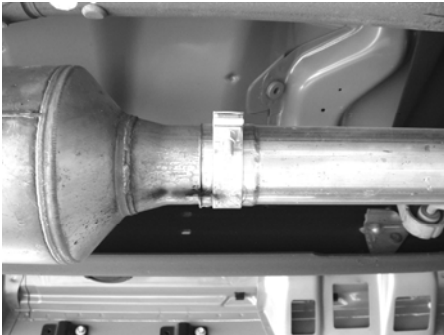

Figure 1



Figure 2

6. Lubricate all hangers and rubber brackets.
7. Unbolt the flange shown in figure 3 located in front of the catalytic converter.
8. Using a muffler stand or an additional person to hold the catalytic converter up in place, remove the hangers from the rubber brackets and remove the catalytic from the vehicle as shown in figure 5.

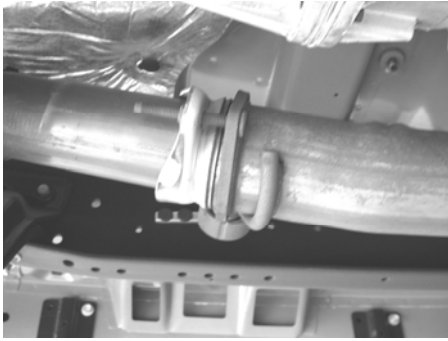

Figure 3

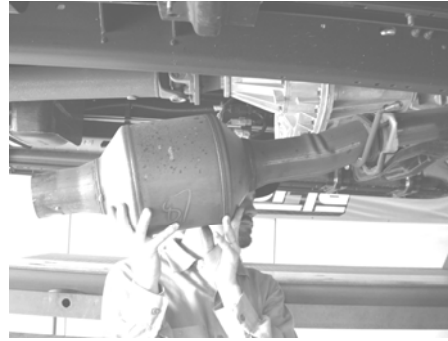

Figure 4

9. From under the vehicle, support the transmission using a transmission jack or something similar.
10. Unbolt and remove the transmission cross member as shown in figure 5.
11. Unbolt and remove the clamp shown in figure 6 located on the outlet side of turbocharger.



Figure 5

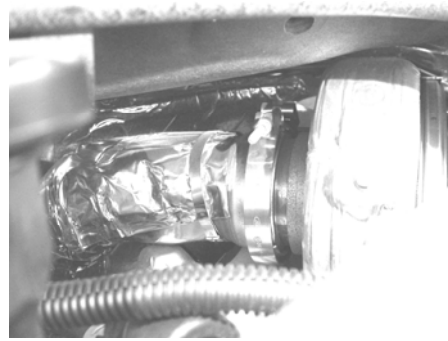

Figure 6

12. Remove the factory down pipe from the vehicle as shown in figure 7.



Figure 7

Borla Performance Down-Pipe Installation

Replacement down-pipes are designed exclusively for farm, line inspection off-highway and competition vehicles where the use of a catalytic converter is a fire hazard and are prohibited from being driven on public or publicly funded roads.

Warning: Use extreme caution during installation. Torque all fasteners according to manufacturer's torque values and tightening sequence. DO NOT use air impact tools to tighten fasteners on Borla Performance Exhaust Systems. Use of such tools may result in bent flanges or gasket contact areas leading to exhaust leaks.

1. Remove pollution control disclaimer from upper down pipe than using the original clamp, place the upper down pipe into position on the outlet side of the turbocharger as shown in figure 8. DO NOT tighten the clamp.
2. Place a clamp over the expanded end of the lower down pipe and set it into position as shown in figure 9. DO NOT tighten the clamp.



Figure 8



Figure 9

3. Place a clamp over the expanded end of the front extension pipe and set it up into position. DO NOT tighten the clamp.
4. Place a clamp over the expanded end of the rear extension pipe and set it into position installing the hangers into the rubber brackets. DO NOT tighten the clamp.
5. Using the original hardware, install the transmission cross member. Secure the hardware to the vehicle manufacturer's recommendations.
6. Install your Borla Performance Cat-Back™ exhaust system using the installation instructions provided with it.
7. Check your exhaust system for proper clearance under the vehicle.
8. Once position has been determined to be correct, tighten the Accuseal clamps to 32-35 ft. lbs.
9. Before starting your vehicle, make sure to check all wires, hoses, brake lines, body parts and tires for safe clearance from the exhaust system.
10. Start vehicle and check for any leaks. If any leaks are found, determine cause (such as loose or incorrectly positioned clamp) and repair as necessary.

Note: When you first start your vehicle after the installation of your new Borla Performance Down-Pipe, there may be some smoke and fumes coming from the system. This is a protective oil based coating used in the manufacturing of mandrel bent performance exhaust tubing. This is not a problem and will disappear within a very short period of time after the exhaust has reached normal operating temperatures.