

## X-Pipe Installation For 2009 Chevrolet Corvette



Precision manufactured using high quality austenitic stainless steel; this system is designed to endure years of heavy use. Installing a Borla Performance Exhaust System on your vehicle will eliminate the restrictive design of the stock exhaust, allowing your engine to discharge exhaust gas easier. The result is more horsepower and torque, longer engine life, and a distinctive throaty growl- all this, with easy bolt-on installation. These installation instructions have been written to help you in the installation of your Borla Performance Exhaust System. Please read it completely before installing your system.

**Thank you for purchasing a Borla Performance X-Pipe.**

**This Borla Performance X-Pipe (Part number 60505) has been designed for 2009 Chevrolet Corvette C6 equipped with a 6.2L V-8 engine and automatic or manual transmissions.**

Borla Performance Industries recommends that an exhaust shop or professional after market parts installer, who has all the necessary equipment, tools and experienced personnel needed for proper installation, should perform the installation of this system. However, if you decide to perform the installation, we recommend someone should help you. Ensure the installer uses all under car safety precautions including eye protection.

*Please take time to read and understand the following...*

By installing your Borla Performance X-Pipe, you indicate that you have read this document and you agree with the terms stated below.

It is the responsibility of the purchaser to follow all installation instruction guidelines and safety procedures supplied with your Borla Performance X-Pipe

Borla Performance Industries assumes no responsibility for damages occurring from misuse, abuse, improper installation, improper operation, lack of responsible care, or all previously stated reasons resulting from incompatibility with other manufacturer's products and/or systems.

Included with your Borla Performance X-Pipe is a warranty card. Please read it carefully before you begin any work on your vehicle. If you should have any questions regarding our warranty policy, installation, or any other matter pertaining to your new Borla Performance X-Pipe, please give us a call at the number provided on the warranty card.

**Minimum Required Tool List:**

**TOOLS:**

- 1 3/8" Drive Ratchet
- 2 3/8" Drive Extension 3"
- 3 13mm Socket
- 4 15mm Socket
- 5 Pry Bar

**SHOP SUPPLIES:**

- 1 Spray Lubricant

**Borla Performance X-Pipe Bill of Materials**

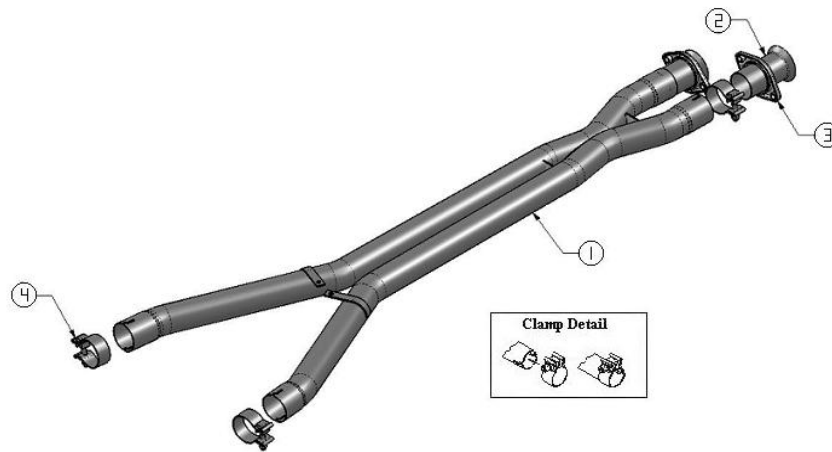

1. X-pipe assembly
2. Flared inlet pipe
3. 2-bolt formed flange
4. 2.50" Accuseal clamp (qty 3)

**Caution!!!** *Never work on a hot exhaust system. Serious injury in the form of burns can result* If the vehicle has been in use and the exhaust system is hot, allow vehicle to cool for at least 1 hour. Always wear eye protection when working under any vehicle.

*Note: It is our recommendation that you use a hoist or hydraulic lift to facilitate the installation of your new Borla Performance X-Pipe.*

Taking all under car safety precautions, lift the vehicle using a hoist or hydraulic lift. Once this has been done, you may begin the removal of your old exhaust system from your vehicle.

**Note: Before removing the original exhaust system from your vehicle, please compare the parts you have received with the bill of materials provided on the previous page to assure that you have all the parts necessary for the installation of your new Borla Performance X-Pipe.**

## Original H-Pipe Removal

*Note: With a used vehicle, we suggest a penetrating spray lubricant to be applied liberally to all exhaust fasteners and allowing a significant period of time for the chemical to lubricate the threads before attempting to disassemble.*

1. Loosen the clamps shown in figure 1 located just under the transmission at the rear of the vehicle.
2. Using a 13mm socket, unbolt the spring hangers located just in front of the clamps as shown in figure 2. Place the bolts aside for use during the installation of your new exhaust system.
3. With a muffler stand or an additional person to hold the h-pipe assembly up into position, using a 15mm socket, unbolt the flanges shown in figure 3 located just behind the catalytic converters. Place the hardware and gaskets to the side for use during the installation of your new Borla Performance X-Pipe.
4. Remove the h-pipe assembly from the vehicle by dropping the front down as shown in figure 4, than sliding the rear portion out of the factory over axle pipe/muffler assemblies .



Figure 1



Figure 2



Figure 3



Figure 4

**Warning:** Use extreme caution during installation. Torque all fasteners according to manufacturer's torque values and tightening sequence. **DO NOT** use air impact tools to tighten fasteners on Borla Performance Exhaust Systems. Use of such tools may result in bent flanges or gasket contact areas leading to exhaust leaks.

## Borla Performance X-Pipe Installation

1. Slide the flange over the flared inlet pipe as shown in figure 5 making sure the chamfered side is facing the flared portion of the pipe.
2. Place a clamp over the expanded end at the front of the x-pipe assembly and place the flared inlet pipe/flange assembly into the x-pipe assembly as shown in figure 6. Do Not tighten the clamp.
3. Place a clamp over the rear expanded ends of the x-pipe assembly and set it up into position as shown in figure 7. Do Not tighten the clamps.
4. Using the original hardware, secure the flanges as shown in figure 8. Hand tighten the hardware for now.
5. Using the original hardware, secure the spring hangers onto the connection pipes as shown in figure 9.
6. Check your x-pipe for proper clearance under the vehicle.
7. Once position has been determined to be correct, tighten the Accuseal clamps to 32-35 ft. lbs. Tighten the flange hardware to 18-22 ft. lbs.
8. Before starting your vehicle, make sure to check all wires, hoses, brake lines, body parts and tires for safe clearance from the x-pipe.

*Note: When you first start your vehicle after the installation of your new Borla Performance X-Pipe, there may be some smoke and fumes coming from exhaust. This is a protective oil based coating used in the manufacturing of mandrel bent performance exhaust tubing. This is not a problem and will disappear within a very short period of time after the exhaust has reached normal operating temperatures.*



Figure 5



Figure 6



Figure 7



Figure 8



Figure 9