

# Jeep 6" Conversion

Set Part # 10913  
Rev-D 03-26-09



## Step 1: Prior to Installation:

(A) Bushwacker only approves installing the flares according to these written instructions with the hardware provided. **WARNING:** Failure to install according to these instructions will invalidate the warranty. This includes, but is not limited to using alternative installation methods, hardware, or materials. **DO NOT USE:** Loctite, SuperGlue, or similar products on the hardware or the flares.

### (B) Verify Fit.

1. Hold the flares onto the vehicle to verify fit.
  - (a) **Vehicle moldings and/or other body accessories may need to be trimmed or removed for proper fit of flares.**
  - (b) **Some filing, sanding, or cutting of flare edge may be necessary to ensure proper fit.**

## Step 2: Painting: (optional)

(A) Painting must be done prior to final installing flares on the vehicle

(B) Clean outer surface of flare with a good grade degreaser.

1. **DO NOT USE LACQUER THINNER OR ENAMEL REDUCER AS A DEGREASER.**
2. Wipe outer surface thoroughly with a tack rag prior to paint.

(C) Paint flares using a high quality enamel, or polyurethane automotive paint. (Application of a primer coat is optional)

(D) If painting edge trim (not recommended) use a flex additive.

## Step 3: Performance:

(A) Using larger Tires may increase the area required to turn the vehicle. Some Tire/Rim combinations may require lowering bump stops and or installing steering stops to prevent tire from contacting flare.

**Step 4: Exhaust System:** Modifications may be necessary to maintain a minimum 4" clearance between flares and exhaust pipes. (Exhaust gases should not vent directly onto flares)

## TOOLS FOR EASY INSTALLATION

- Utility Knife
- Drill
- Drive bit extension
- #2 Phillips Drive bit/Screw Driver
- Socket Wrench
- 8mm socket
- 8mm wrench
- Automotive trim pry tool
- 1/4" Drill Bit
- Drill Motor

## FLARE INSTALLATION PROCEDURES

Illustration #1

### Step 5: Preparing the Work Area (Front and Rear)

- (A) Remove the marker light from the factory front fender flares.
- (B) Remove the rear wheel well liner using an automotive trim pry tool (a pry bar or claw hammer can work) to release the Christmas tree fasteners. Save for re-installation.
- (C) Remove the factory fender flares and stone guards using an 8mm socket and 8mm wrench.

### Step 6: Edge Trim Installation (See Illustration #1)

- (A) Peel two to three inches of red vinyl backing away from edge trim tape. Applying the adhesive side of the edge trim to the inner side of the flare, affix the edge trim to the top edge of the flare (the portion that comes in contact with the vehicle). **See Illustration #1**
- (B) Press edge trim into place along the top edge of the flare in one-foot increments, pulling red vinyl backing free as you continue to work your way around the top edge of the flare.



## Step 7: Flare and Stone Guard Installation

- (A) Install the marker lights from the factory front flares into the marker light area formed in the Bushwacker front flares.
- (B) Place a supplied washer on each Torx head screw in the hardware kit.
- (C) Place a Torx head screw / washer through the hole in one of the pockets in the flare.
- (D) Slide a 3/8" thick rubber spacer onto the screw from the back side of the pocket until snug.
- (E) Repeat steps 7:(B&C) for the remaining pockets in the flares.
- (F) Holding the flare into position on the fender, insert the screws through the factory holes in the fender.
- (G) To hold the flare in place on the fender, start a supplied nut onto one of the screws in the top area of the flare and leave loose.
- (H) Gently start the screws that correspond with the factory threaded inserts and leave screws loose.
- (I) Start a supplied nut onto the rest of the screws.
- (J) Tighten all the screws using a drive bit extension, the supplied T-30 Torx bit and an 8mm wrench.
- (K) Fasten the stone guard to the vehicle with the factory screws that were previously removed.

## Step 8: Front Bumper Piece Installation

- (A) Using the supplied T-30 Torx Bit remove the factory bumper end caps.
- (B) Holding the bumper piece in position on the bumper, place a Torx head screw / washer through each of the holes in the front of the bumper piece.
- (C) Start a supplied nut on the screws and tighten partially with the supplied T-30 Torx bit and an 8mm wrench.
- (D) Line up the bumper piece and flare at the wheel well. (See Illustration #3 and 4).
- (E) (There is a hole in the bumper piece and not in the flare). With a pencil or marker, mark the flare through the hole in the bumper piece. (See illustration #4).
- (F) Pull bumper piece wheel well area out of way before drilling marked hole in flare with 1/4" bit.
- (G) Drill hole.
- (H) Slide a supplied clip onto the fender flare under the marker light aligning it with the hole in the flare just drilled in step "G".
- (I) Fasten the bumper piece to the flare with a supplied #2 Phillips screw.

Illustration #2

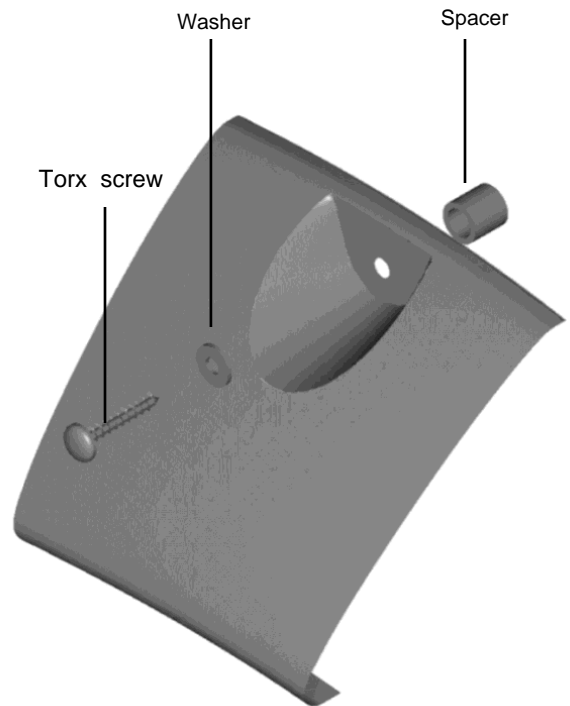

Illustration #3

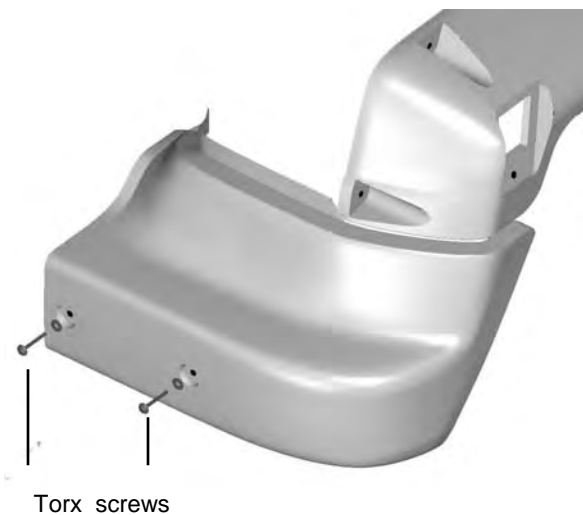
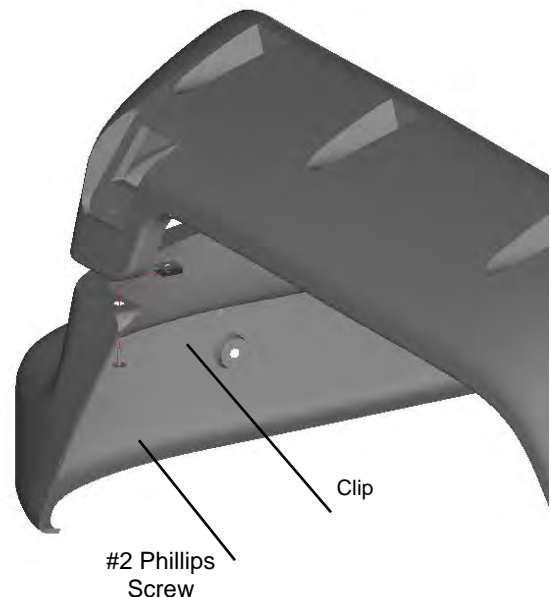

Illustration #4



## Step 9: Seating Edge Trim

- (A) Using supplied Edge Trim Tool, seat edge trim against vehicle by hooking curved end under edge trim at one end of flare. Next, slide around outer edge of flare to the other end. **See Illustration #5.**
- (B) Using flat end of supplied Edge Trim Tool, seat edge trim against flare by inserting straight end between edge trim and flare at one end. Next, slide around entire edge to the other end. **See Illustration #6.**



**Illustration #5**



**Illustration #6**