

STEP 1 – PRIOR TO INSTALLATION

- A) Bushwacker only** approves installing the flares according to these written instructions with the hardware provided. **WARNING:** Failure to install according to these instructions will invalidate the warranty. This includes, but is not limited to using alternative installation methods, hardware, or materials. **DO NOT USE:** Loctite, SuperGlue, or similar products on the hardware or the flares.
- B) Fit:** Verify the fit of the flares to vehicle. (Some filing, sanding, or cutting may be necessary to ensure proper fit).
- C) Painting:** (Optional) if paint is desired it must be done prior to installing flares on vehicle. Clean outer surface with a good grade degreaser. **DO NOT USE LACQUER THINNER OR ENAMEL REDUCER AS A DEGREASER.** Wipe outer surface thoroughly with a tack rag prior to paint. Application of plastic adhesion promoter for ABS plastic as per your paint system manufacturer's recommendations is required. Paint flares using a high quality enamel, or polyurethane automotive paint. If painting edge trim (not recommended), use a flex additive.
- D) Performance:** Using larger Tires may increase the area required to turn the vehicle. Some Tire/Rim combinations may require lowering bump stops and or installing steering stops to prevent tire from contacting flare.
- E) Exhaust System:** Modifications may be necessary to maintain a minimum 4" clearance between flares and exhaust pipes. (Exhaust gases should not vent directly onto flares)
- F) Metal Protection:** All exposed fasteners and bare metal should be treated with rust resistant paint **BEFORE** installing flares. Spray inner fender wells with undercoating **AFTER** flare attachments have been completed.
- G) Decals:** Flares may interfere with existing decals on vehicle. If you wish, remove decals prior to installation of flares.

Ford Cut-Out™ Fender Flares Front Pair

Front Part #20047-02

Rev-4 9/6/2013

For complete fitment info visit : www.bushwacker.com

TOOLS FOR EASY INSTALLATION:

- Grease Pencil
- Masking Tape
- Measuring Tape
- Pry Tool
- Pliers
- #2 Phillips Driver
- Socket Wrench
- 8 mm Socket
- 7/32 mm Socket
- Electric Drill
- 1/8" Drill Bit
- 13/64" Drill Bit
- Awl or Similar Pointed Tool
- Angle Grinder
- Cut Off Wheel
- Sawsall
- Center Punch
- Hammer

LIMITED LIFETIME WARRANTY AGAINST ANY MANUFACTURING DEFECTS

- To claim a warranty, you must provide Proof of Purchase.

Included in Hardware Kit:

- | | | | | | | | | | | | | | |
|----|---|----|---|----|---|----|---|----|--|----|---|----|---|
| 1. |  | 2. |  | 3. |  | 4. |  | 5. |  | 6. |  | 7. |  |
| | CL1-0022,
#10 "U" Clip,
4 pcs | | SW1-0056,
#8 x 3/4"
PH Screw,
10 pcs | | SP1-0009,
3/8" x 5/8" x .187"
Neo Black Spacer,
18 pcs | | SW1-0045,
#14-14 x 1"
Torx Screw,
18 pcs | | SW1-0052,
T-45 Torx Bit,
1 pc | | GP1-0008,
Duro (NC02/S 70)
Edge Trim,
156 inches | | ET1-0002,
Edge Trim Tool,
1 pc |

STEP 2 - EDGE TRIM INSTALLATION

A. Peel two to three inches of red vinyl backing away from Edge Trim (GP1-0008) tape. Applying the adhesive side of the edge trim to the inner side of the flare, affix the edge trim to the top edge of the flare (the portion that comes in contact with the vehicle).

B. Press edge trim into place along the top edge of the flare in one-foot increments, pulling red vinyl backing free as you continue to work your way around the top edge of the flare.



Front Flare Installation Procedures (Driver's Side):

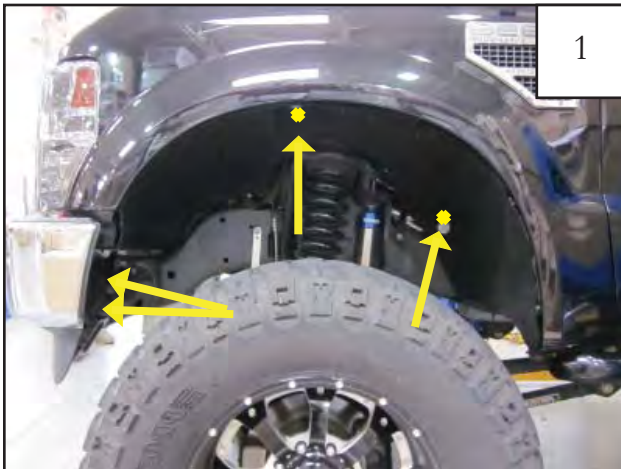

Remove four factory installed screws inside wheel well with 8 mm socket wrench. *Save for reinstallation.*

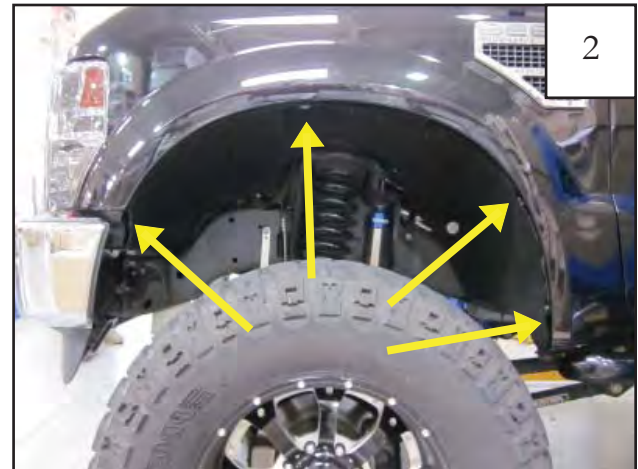

Remove four factory installed screws along edge of wheel well using a 7/32mm socket wrench.



Using a pry tool, remove factory installed tufloc rivet located at the bottom rear of the wheel well.



Remove the splash guard.

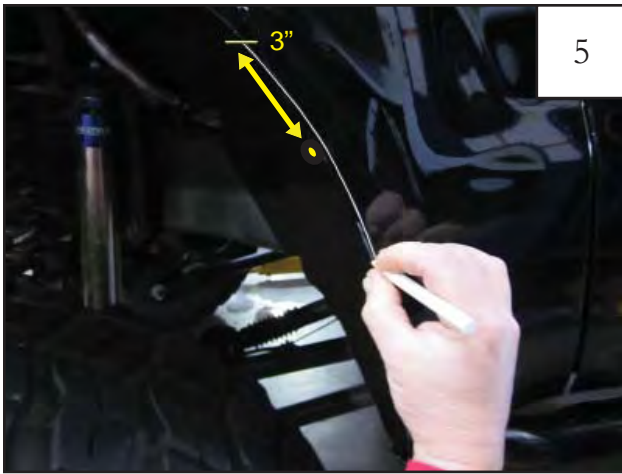

5

Use grease pencil to mark edge of inside wheel well flange. Start 3" up from top flange screw hole.

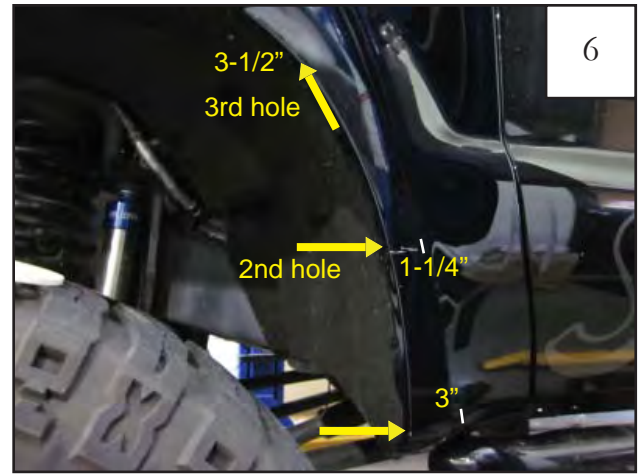

6

Measure 3" from edge of rearward wheel well and mark with grease pencil. Make another mark 1-1/4" in from 2nd factory hole from the bottom. Make last mark 3-1/2" up from 3rd hole from the bottom.



7

Using marks as a guide, use masking tape to create an arc from the lower mark to the upper mark. Inner edge of tape should be *outside* of marks made in previous step.

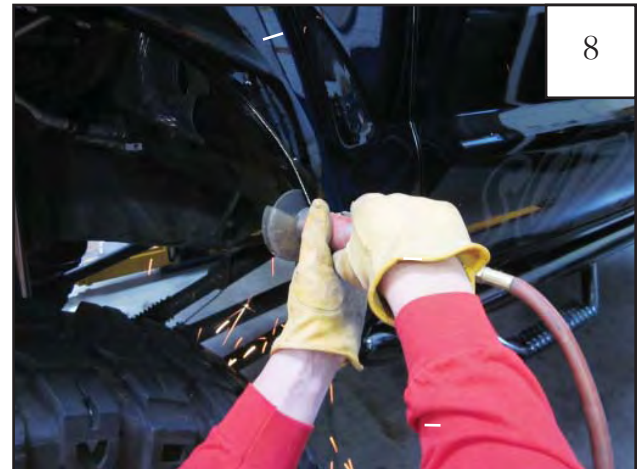

8

Using a cut-off wheel, cut and remove inner flange.



9

Mark fender with grease pencil about every 2" up to edge of masking tape.



10

Using a cut-off wheel, cut fender along marked lines up to inner edge of tape.

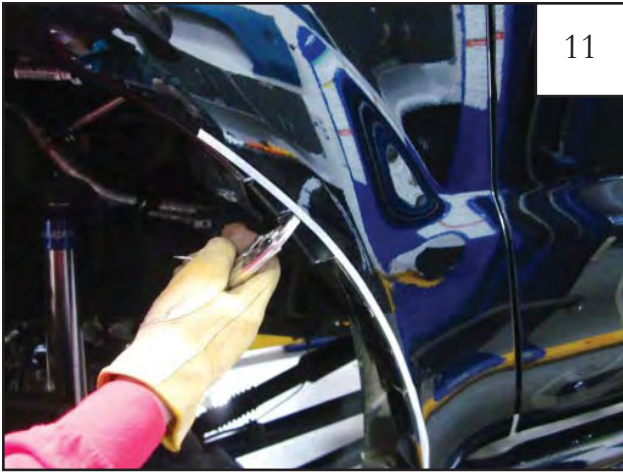

Bend tabs into wheel well with pliers and flatten.

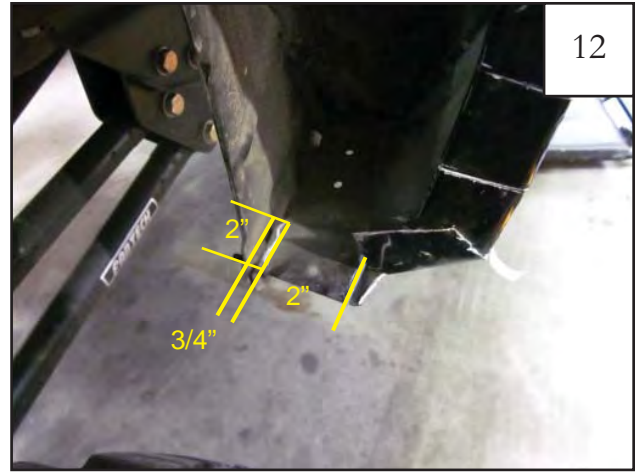

Using a tape measure and grease pencil, make a mark 3/4" from back of wheel well, then 2" from first mark. Then make two parallel lines 2" long inside of bottom rearward flange as shown.



Using a Sawsall, cut off outlined area.



Using cut-off wheel, cut marked lines along bottom flange.

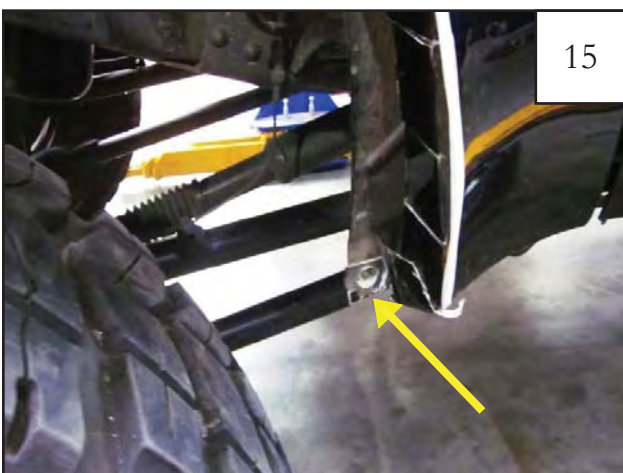

Remove factory screw located at back of wheel well.



Using a grease pencil, make a line on flange at back of wheel well parallel to the outer edge. Using a cut-off wheel, cut away flange area indicated. **DO NOT CUT BACK WALL OF WHEEL WELL.** See step 17.



17

This is how it should look after you cut off back lower flange.



18

Draw a line along the inner wheel well wall that parallels the outer edge.



19

Using a Sawsall, cut along reference line.



20

Using a hammer and an angle grinder, flatten tabs then grind down any sharp edges.

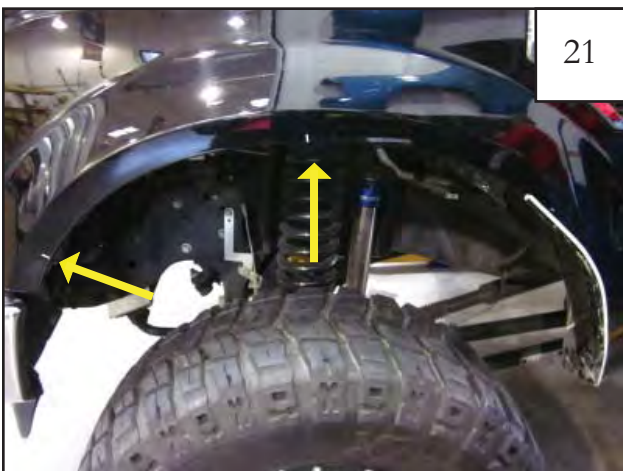

21

Install Clip (CL1-0022) in two locations. See Step 22 & 23.

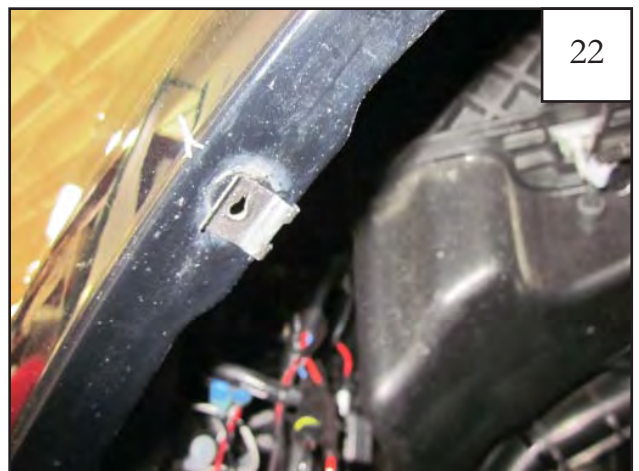

22

Install Clip (CL1-0022) over hole on outer edge where indicated in Step 21.



23

Install flare and start Screw (SW1-0056) through clips installed in previous step with a #2 Phillips Driver. *Do not tighten.*



24

Hold flare tightly against fender, lining it up along style lines, drill into sheet metal through pre-drilled flare holes at rear side using 1/8" drill bit.



25

Install screw (SW1-0056) into holes drilled in previous step. **Tighten ALL** screws installed in Steps 23 & 24 to ensure proper alignment of flare for pocket hardware installation.



26

Hold flare in place. Using a scratch awl and pocket holes in flare as a guide, mark vehicle for drilling.



27

Remove screws and flare. Using marks made with scratch awl as a guide, use a center punch to score sheet metal prior to drilling.



28

Using a 1/8" bit, drill marked hole locations. Then, using a 13/64" bit, drill holes again.



Reinstall splash guard using saved factory clips to fasten to outer edge.

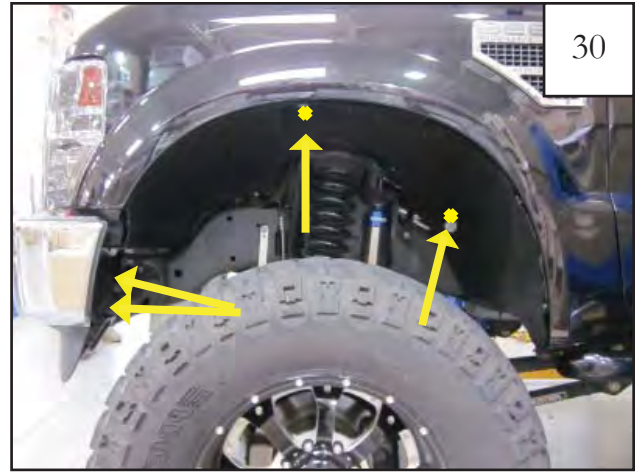

Reinstall saved factory screws through splash guard using 8mm socket.



Thread bolt (SW1-0045) through pocket hole in flare then install spacer (SP1-0009) over end of bolt. *Hand tighten* spacer on bolt until snug near flare plastic.



Install flare using screw (SW1-0056) through holes indicated.



Using torx bit (SW1-0052), *start* bolts installed in Step 31 through holes drilled in Step 28. *Once all bolts are in place, tighten all screws.*



Completed front flare installation.

Edge Trim Tool Procedures:

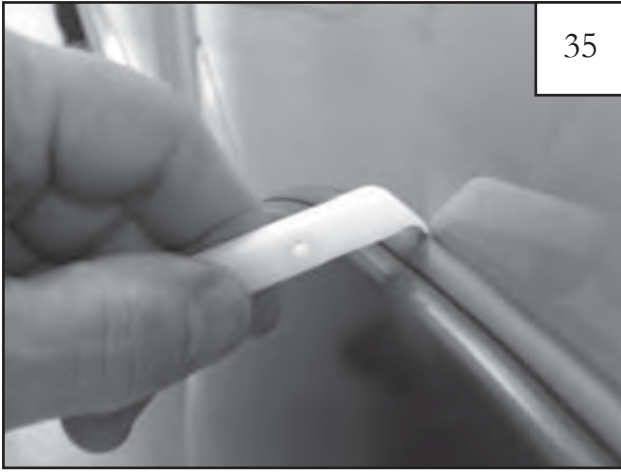

Using supplied Edge Trim Tool (ET1-0002), seat edge trim against vehicle by hooking curved end under edge trim at one end of flare. Next, slide around outer edge of flare to the other end.



Using flat end of supplied Edge Trim Tool (ET1-0002), seat edge trim against flare by inserting straight end between edge trim and flare at one end. Next, slide around entire edge to the other end.

Flare Height & Tire Coverage (Driver's Side):

