



INSTALLATION INSTRUCTIONS FOR Ford Expedition, 20503

20503
Rev-1
12/08/09

TOOLS REQUIRED FOR INSTALLATION:

- Jack and Jack Stands
- Medium Phillips Head Screwdriver
- Red Oxide Primer
- Electric Drill
- 3/16" Drill Bit
- Duct Tape

IMPORTANT: READ BEFORE BEGINNING INSTALLATION

Verifying Fit – Flare parts should be held to the vehicle surface to verify correct type and fit BEFORE beginning installation or painting. Small fit adjustments can be made by trimming (filing, sanding, or scraping) excess plastic.

Exhaust system - Modifications may be necessary to maintain a minimum 4" clearance between flares and exhaust pipes. Exhaust gases should not vent directly onto flares.

Metal Protection – All bare metal should be treated with red oxide primer BEFORE installing flares.

DO NOT USE: Loctite, SuperGlue, or similar products on the hardware or the flares.

FLARE INSTALLATION PROCEDURES

Note: should additional room between the tire and wheel well rim be required, support vehicle and remove wheel using jack and jack stands.

Step 1: Painting Flares (Optional)

It is recommended that painting (when desired) be done prior to installation.

- (A) Sand (optional) before application of paint.
- (B) Clean outer surface with a good grade degreaser. DO NOT USE LACQUER THINNER OR ENAMEL REDUCER as a degreaser. Wipe outer surface thoroughly with a tack cloth prior to painting.
- (C) Paint flares using a high quality enamel or polyurethane automotive paint. Application of a primer coat is optional.
- (D) Use a flex additive when painting edge trim.

Step 2: Preparing Flare and Fender

- (A) Remove factory installed fender trim when necessary.
- (B) Pre-fit flare parts to wheel well area and trim if necessary.
- (C) Install edge trim along outside edges of flare as shown in Illustration #1.
- (D) Attach edge trim to the flare using the pre-applied adhesive strip. **Adhesive strip should be placed against the inside surface of the flare.** See Illustration #2 – "Edge Trim Detail." To use the pre-applied adhesive strip, pull 4 inches of plastic protective covering from adhesive before pressing edge trim onto flare. After edge trim is in place on flare, pull off remaining tape protection and press edge trim firmly against flare.

Step 3: Attaching Front Flares

Front and rear flares can be attached as a replacement for factory equipment or as an accessory.

- (A) Remove and save the four screws used to hold the wheel well liner (and mud flap when installed) along inside rim of wheel wells.
- (B) Drill six 3/16" holes at the indents located along the inside surface of the flare.
- (C) Tape the flare in position on the fender, and mark two drill locations on the wheel well inner lip and fender roll-under area. These locations are shown as Kit Supplied in Illustration #1 – "Front."
- (D) Remove flare and drill two 9/64" holes with kit supplied drill bit at the locations marked in Step 3C.
- (E) Secure flare to fender at 4 original hole locations and at the two locations drilled in Step 3D. Secure using both the original screws and kit provided screws. Secure mud flap and lower rear portion of flare with original screws.

Step 4: Attaching Rear Flares

- **As a new installation:**
 - (A) Remove mud flap (when installed) and save screws.
 - (B) Drill ten 3/16" holes at the indents located along the inside surface of the flare.
 - (C) Tape the flare in position on the fender. Using the holes drilled in the flare as a guide, mark drill locations on the wheel well inner lip and fender roll-under areas.
 - (D) Using kit supplied drill bit, drill 9/64" holes as previously located in wheel well inner lip and fender roll-under areas.
 - (E) Attach the flare to the fender using the kit supplied screws and the original screws from step 4A.
- **As a replacement for factory flares:**
 - (A) Remove factory flare and mudflap (when installed) and save screws.
 - (B) Repeat Step 4B above.
 - (C) Attach the flare to the fender using the eight screws removed from the factory flare; use two kit supplied screws at the bottom of the flare to attach to the fender roll-under areas. See Illustration #1 – "Rear."

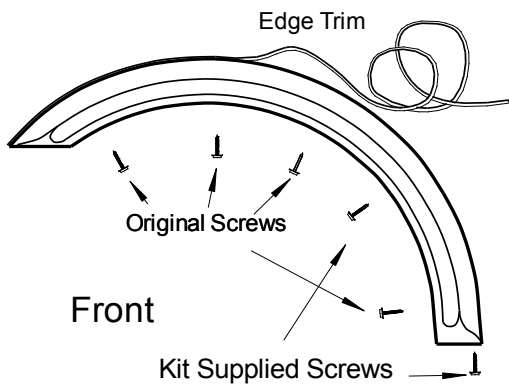
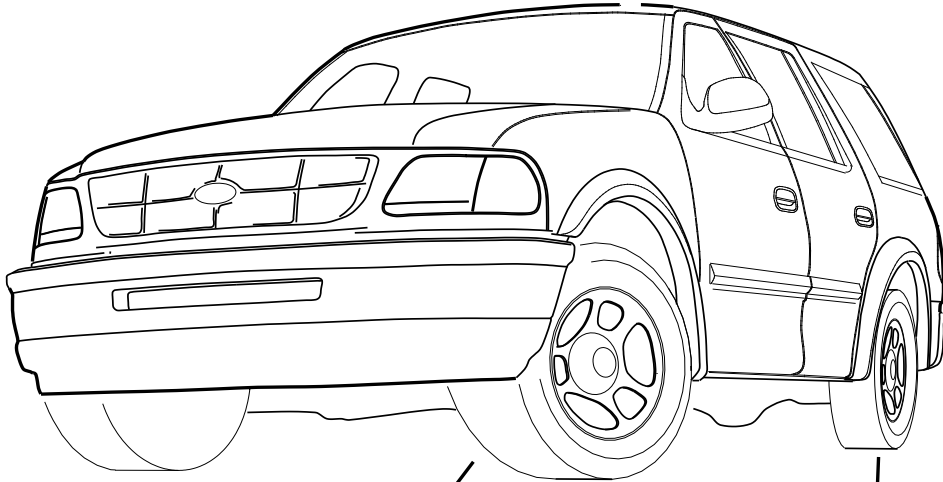

Illustration #1

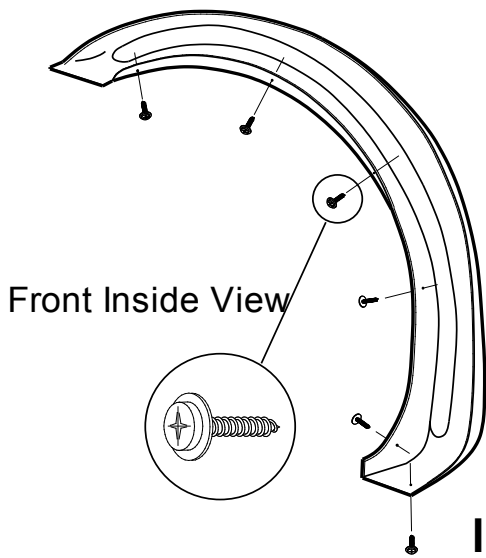
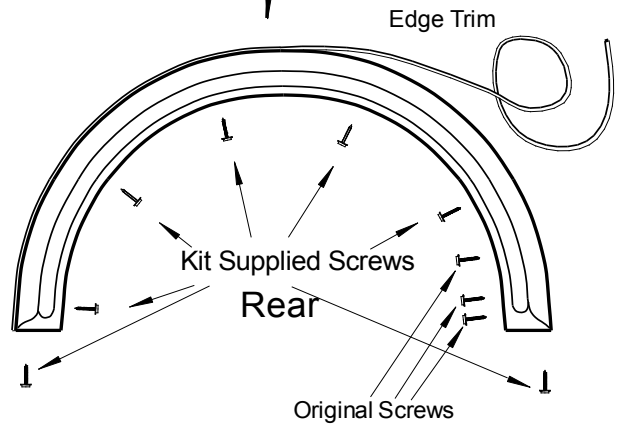

Illustration #2

