



INSTALLATION INSTRUCTIONS FOR Ford Excursion OE Style Flare Part # 20910

**IMPORTANT:
READ INSTRUCTIONS THOROUGHLY BEFORE BEGINNING INSTALLATION**

TOOLS REQUIRED FOR INSTALLATION:

- Electric Drill
- #2 Phillips Driver Bit
- 3/16" Drill Bit
- 7/32" Socket
- Socket Wrench
- Tape Measure
- Utility Knife

FLARE INSTALLATION PROCEDURES

Step 1: Verifying fit

- (A) Verify Fit by holding Bushwacker flares against the vehicle body. Small fit adjustments can be made by trimming excess plastic.
- (B) **DO NOT USE:** Loctite, SuperGlue, or similar products on the hardware or the flares.

Step 2: Painting.

Note: Painting (when desired) must be done after fit verification, but prior to full installation.

- (A) Clean outer surface with a good grade degreaser. **DO NOT USE LACQUER THINNER OR ENAMEL REDUCER AS A DEGREASER.** Wipe outer surface thoroughly with a tack rag prior to painting.
- (B) Paint Flares using a high quality lacquer, enamel, or polyurethane automotive paint. Sanding or application of a primer coat is optional.

Step 3: Edge Trim Installation

- (A) The 26' roll of edge trim that is included with each kit needs to be cut to the following lengths: two 67" pieces, and two 85" pieces.
- (B) Peel two to three inches of red vinyl backing away from the edge trim tape. Applying the adhesive side of the edge trim to the inner side of the flare, affix the edge trim to the top edge of the flare (the portion that comes in contact with the side of the vehicle).
- (C) Press edge trim into place along the top edge of the flare in one-foot increments, pulling red vinyl backing free as you continue to work your way around the top edge of the flare.

See Illustration #1.

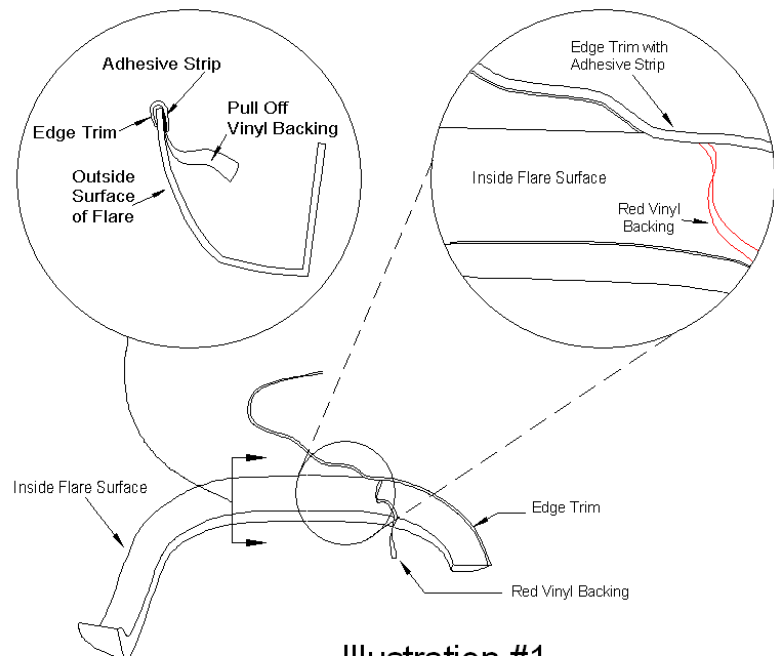

Illustration #1

Step 4: Front Flare Installation

- (A) Pre-drill all flares with a 3/16" drill bit using the indents formed into the flare as a guide.
- (B) Remove the three factory screws from front wheel well using the 7/32" socket.
- (C) Holding front flare in place on fender, secure with factory screws through holes drilled in flare. **See FIGURE 2.**

Step 5: Rear Flare and Rocker Panel Installation

- (A) Removing factory rocker panel pieces
 1. Remove the two screws at the inside lip of the wheel well using a 7/32" socket and a Phillips drill bit.
 2. Cut the four Christmas tree type fasteners at the lower inside edge of the sheet metal using a utility knife or snips.
 3. Squeeze and twist the four barbed clips from inside the sheet metal using pliers to release the part.
- (B) FOR PROPER INSTALLATION OF TAPE, the vehicle, the parts to be installed, and the tape should be between 60° and 110°F for proper adhesion.
- (C) Adhere a strip of double stick tape along the top and bottom edges of the Replacement Rocker Panel Piece. Apply 30 lbs. of pressure per inch of tape for proper bond.
- (D) Pre-drill all flares with a 3/16" drill bit using the indents formed into the flare as a guide. Applying moderate pressure to the outside surface of the rear flare, fasten with five kit supplied drill tip screws using the holes in the flare as a guide. **See FIGURE 3.**

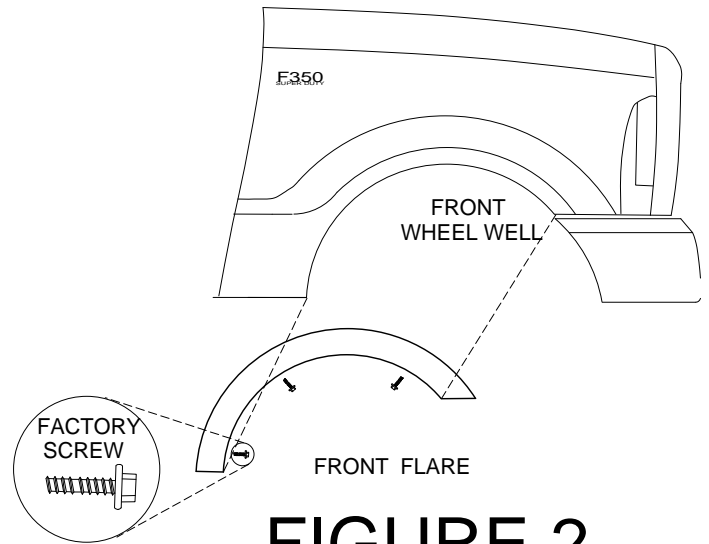

FIGURE 2

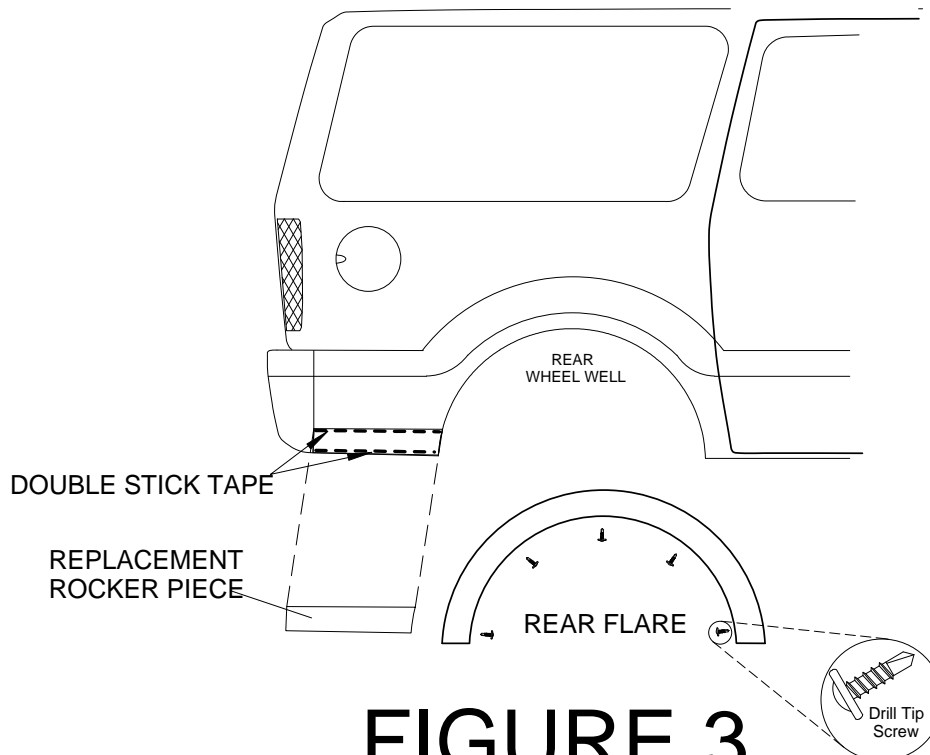

FIGURE 3