



INSTALLATION INSTRUCTIONS FOR

Toyota Tundra

Extend-A-Fender® 30902

TOOLS REQUIRED FOR INSTALLATION

- 10 mm Socket / Ratchet
- Utility Knife

IMPORTANT: READ BEFORE BEGINNING INSTALLATION

Verifying Fit – Flares should be held to the vehicle surface to verify correct type and fit BEFORE beginning installation or painting. Small fit adjustments can be made by trimming (filing, sanding or scraping) excess plastic.

Exhaust System - Modifications may be necessary to maintain a minimum 4" clearance between flares and exhaust pipes. Exhaust gases should not vent directly onto flares.

DO NOT USE: Loctite, SuperGlue, or similar products on the hardware or the flares.

FLARE INSTALLATION PROCEDURES

Note: Should additional room between the tire and wheel well rim be required, support vehicle and remove wheel using jack and jack stands.

Step 1: Painting

It is recommended that painting (when desired) be done prior to installation.

- (A) Sand (optional) before application of paint.
- (B) Clean outer surface with a good grade degreaser. **Do not use lacquer thinner or enamel reducer as a degreaser.** Wipe outer surface thoroughly with a tack rag prior to painting.
- (C) Paint flares (with or without edge trim) using a high quality lacquer, enamel, or polyurethane automotive paint. Application of a primer coat is optional

Step 2: Preparing Flare and Fender

Note: Flare and Edge Trim must be above 55° F for complete bonding of tape.

- (A) Remove factory installed edge trim when necessary.
- (B) Pre-fit flare parts to wheel well area and trim if necessary.
- (C) Lightly sand any overspray on backside of flare where tape is to be applied. Clean application area with a 50/50 alcohol/water solution, and dry with a clean cloth.
- (D) Peel two to three inches of red vinyl backing away from edge trim tape. Applying the adhesive side of

the edge trim to the inner side of the flare, affix the edge trim to the top edge of the flare (the portion that comes in contact with the side of the vehicle). Press edge trim into place along the top edge of the flare in one-foot increments, pulling red vinyl backing free as you continue to work your way around the top edge of the flare.

See FIGURE 1.

- (E) Repeat Steps 2A and 2B for remaining flares.

Step 3: Attaching Front Flares

- (A) Remove and save 3 screws from inside rim of wheel well. Remove and save 2 outer screws securing mud flap to vehicle. See FIGURE 3.
- (B) Attach mounting brackets to front flare through top three holes in flare and 1/4" hole in bracket with Tuflok® fasteners. See FIGURES 2 & 4.
- (C) Pressing the flare firmly against the body while tightening, secure flare to fender using the screws removed in step 3A and the 2 screws supplied in the kit. See FIGURE 3.

Step 4: Attaching Rear Flares

- (A) Remove and save 2 screws holding mud flap to vehicle.
- (B) In vehicles without chrome strips, snap in kit-supplied nylon screw grommets in the square holes in wheel well.

(C) Secure flare to fender using 2 screws removed in last step and 4 screws supplied in kit.

See FIGURE 5.

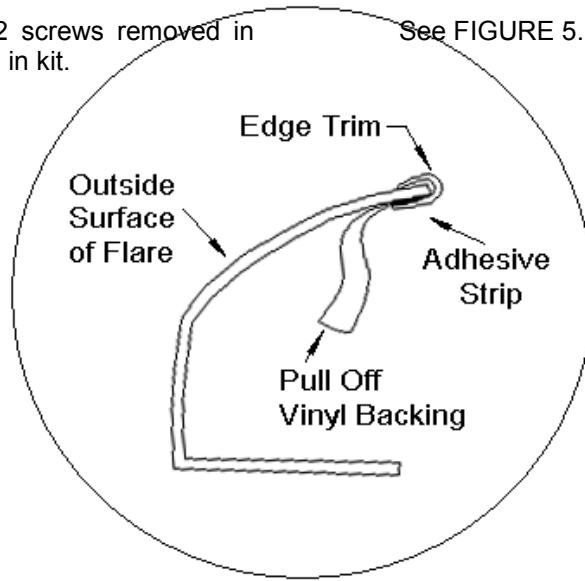

FIGURE 1

FIGURE 2

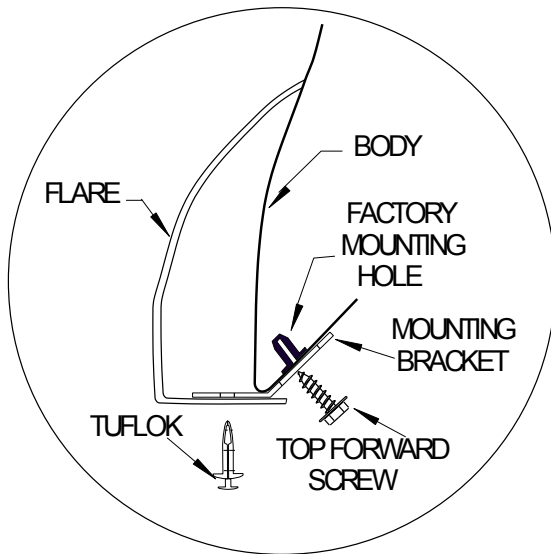

FIGURE 3

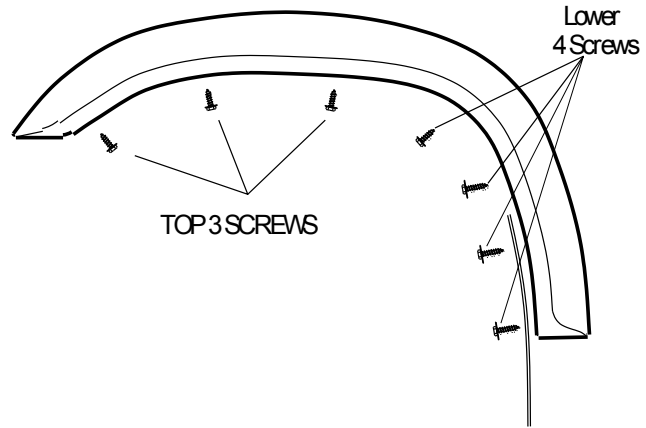

FIGURE 4

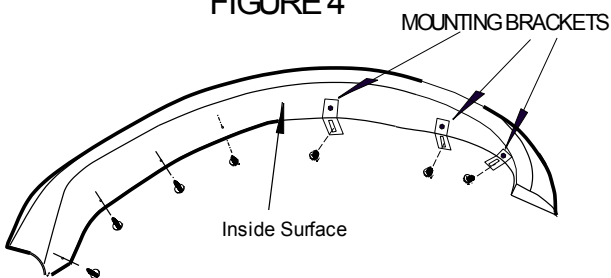

FIGURE 5

