



INSTALLATION INSTRUCTIONS FOR 4-DOOR EXTEND-A-FENDER® FLARES

31907 TOYOTA 4RUNNER
(2 DOOR & 4 DOOR), 41904 S-10 BLAZER,

Tools Required for Installation:

- ¼" (7mm) Drill Motor
- 11/64" (5mm) Drill Bit
- 7/32" (6mm) Drill Bit
- ¼" (7mm) Drill Bit
- Phillips Screw Driver
- Clean Wiping Cloth
- Silicone Sealant
- Pop Rivet Gun
- Sand Paper
- Utility Knife

CAUTION: No direct contact of exhaust gases or exhaust system on flares. A minimum 4" (100mm) clearance required. Exhaust system modifications may be necessary.

Pre-fit ALL flares to vehicle BEFORE painting and/or final installation.

Flares and edge trim MUST BE 55°F (13°C) or above for complete bond of tape.

P/N 31907 Toyota 4Runner WILL NOT fit with factory running boards.

DO NOT USE: Loctite, SuperGlue, or similar products on the hardware or the flares.

STEP 1: PAINTING

It is recommended that painting (when desired) be done prior to installation.

- (A) Sand (optional) before application of paint.
- (B) Clean outer surface with a good grade degreaser. DO NOT USE LACQUER THINNER OR ENAMEL REDUCER AS A DEGREASER. Wipe outer surface thoroughly with a tack rag prior to painting.
- (C) Paint flares using a high quality lacquer, enamel, or polyurethane automotive paint. Application of a primer coat is optional.
- (D) If painting edge trim (not recommended) use a flex additive.

STEP 2: ACCENT MOLDING AND MUD FLAP REMOVAL

- (A) Remove accent molding from around all wheel openings, if so equipped.
- (B) Remove factory flares and/or mud flaps from all wheel openings, if so equipped.
- (C) 31907 ONLY: Factory stone guard at front of rear wheel opening must be removed or cut where flare intersects.

STEP 3: SIDE MOLDING MODIFICATION

- (A) On vehicles equipped with body side moldings that interfere with flare attachment, it will be necessary to modify either the molding or flares.
- (B) Modifying the Side Moldings:
Place flare into wheel well opening and mark a line across molding where flare intersects. Remove flare. Repeat process for rear door flare. Rubber or vinyl moldings can be cut on the vehicle. Warm molding with a heat gun or hair dryer. Carefully slide a flexible wide blade putty knife between the molding and sheet metal; this will act as a shield to prevent cutting paint. Make cut with a SHARP utility knife. NOTE: BACK ANGLE CUT on the long side of marked line. This will match flare angle and leave material if another cut is necessary. Metal moldings have to be removed from vehicle for cutting.
- (C) Modifying Flare:
Place flare into wheel well and mark flare where side molding intersects. Remove flare and mark thickness of molding onto flare. Repeat process for rear door flare. Trim (cut, file or grind) flare on marked line. You may want to drill a 1/8" (4mm)

hole at corners and trim to them. This will give you a smooth, more finished look to the cut. Depending on style and how close molding comes to door edge, it may be necessary to notch or cut door flare mounting bracket into two segments.

STEP 4: PRE-ATTACHMENT (FRONT AND REAR)

- (A) With flare off vehicle, drill all fastener indentations or relocated attachment points on flare with a 1/4" (7mm) drill bit. Some flares may have a relief(s) on attachment flange for existing wheel well fasteners. Relief(s) can be cut out to go over head of fastener or drilled for fastener to go through. Verify location(s) before cutting or drilling.
- (B) If flare has been painted, sand any overspray on backside where edge trim tape is to be applied. Also, lightly sand sharp edge that trim will cover. This will help prevent flare from cutting into edge trim. Clean back side of flare with alcohol. Wipe dry with a clean cloth.
- (C) Using flare edge trim provided, starting at front of flare (leave liner on tape), push trim over edge and work around to opposite end. Cut trim 2" (50mm) longer than flare. On the rear flare there will be three segments of edge trim: lower front, door flare, and rear.
- (D) If there are any contour changes on your flare that cause the outside of trim to wrinkle, mark back side where this occurs. Remove edge trim from flare and notch or "V" marked area using a knife or scissors.
- (E) Clean back side of flare where tape is applied. Peel liner on tape back 3" (76mm). Starting at front of flare, push trim over edge and press out. Continue pushing trim over flare edge and peeling liner back until complete at lower rear. The rear flare uses the same procedure on the three segments of edge trim. It isn't necessary to stretch or pull trim while applying. Press out tape area two more times and trim off excess length.

STEP 5: FLARE ATTACHMENT (FRONT AND REAR-BODY)

NOTE: ATTACHMENT OF PART NUMBER 31907 IS COMPLETED WITH STEP 5. THIS PART NUMBER DOES NOT HAVE A SEPARATE DOOR FLARE OR MOUNTING BRACKET.

- (A) Place flare into appropriate wheel well opening as marked on bottom of flare (R/F = Right Front). Make sure outer edge of flare is tight against body and contours align. Make sure rear body flare doesn't overlap onto door. Using the 1/4" (7mm) holes drilled in Step 4A as a guide, drill (1/4" (7mm) drill bit) two locations at top center. Insert plastic fasteners and secure. Continue to drill and fasten in an alternating pattern until flare is secured. You may want to drill all holes first, remove flare, paint drilled sheet metal, then re-

apply flare and secure. See Illustration Numbers 1, 2, and 3.

STEP 6 FLARE ATTACHMENT (REAR – DOOR)

The hardware supplied for the attachment of the door flare mounting bracket requires drilling through door. If this is a concern to you the following adhesives can be used in place of rivets.

1. Devcon Plexus – 2 part epoxy in a syringe.
2. Bostik Fast Set 1000 Urethane – 1 component in a caulking tube.
3. 3M #08609 Superfast Urethane Auto Glass Sealant – 1 component in a caulking tube.
4. 3M #4950 VHB Double Coated Acrylic Foam Tape – roll.

NOTE: Please read application instructions as cleanliness of parts and temperature are critical. DO NOT USE any "Super Glue" type of adhesives as they DO NOT HAVE THE IMPACT STRENGTH REQUIRED.

- (A) Pre-drill all rivet locating indentations on mounting bracket with a 7/32" (6mm) bit.
- (B) Mark a line 1/8" (3mm) from door edge. See Illustration Number 4. Place mounting bracket on door and register to sheet metal contour while aligning inside edge with marked line. NOTE: You may want to tape mounting bracket in place before final attachment. This will ensure it is in the correct position and outer edge of door flare is in alignment with body flare. Using pre-drilled holes in mounting bracket as a guide, drill sheet metal with an 11/64" (5mm) bit. Apply a small amount of silicone to drilled hole to seal raw edge. Secure with pop rivet supplied. Continue to drill and fasten until secured. See Illustration Numbers 2 and 5.
- (C) Pre-drill all rivet locating indentations on underside of door flare only with a 7/32" (6mm) bit.
- (D) Apply a bead of silicone on face of door mounting bracket. See Illustration numbers 5 and 6.
- (E) Place door flare over mounting bracket and align ends with door. Using the 7/32" (6mm) pre-drilled holes in door flare as a guide, drill mounting bracket with 11/64" (5mm) bit. Secure with pop rivet supplied. Continue to drill and fasten until secured. Make sure outer and inner edges of flare are tight against the body when drilling and fastening. See Illustration Number 5.
- (F) Re-apply trimmed body side moldings, if removed and / or so equipped.

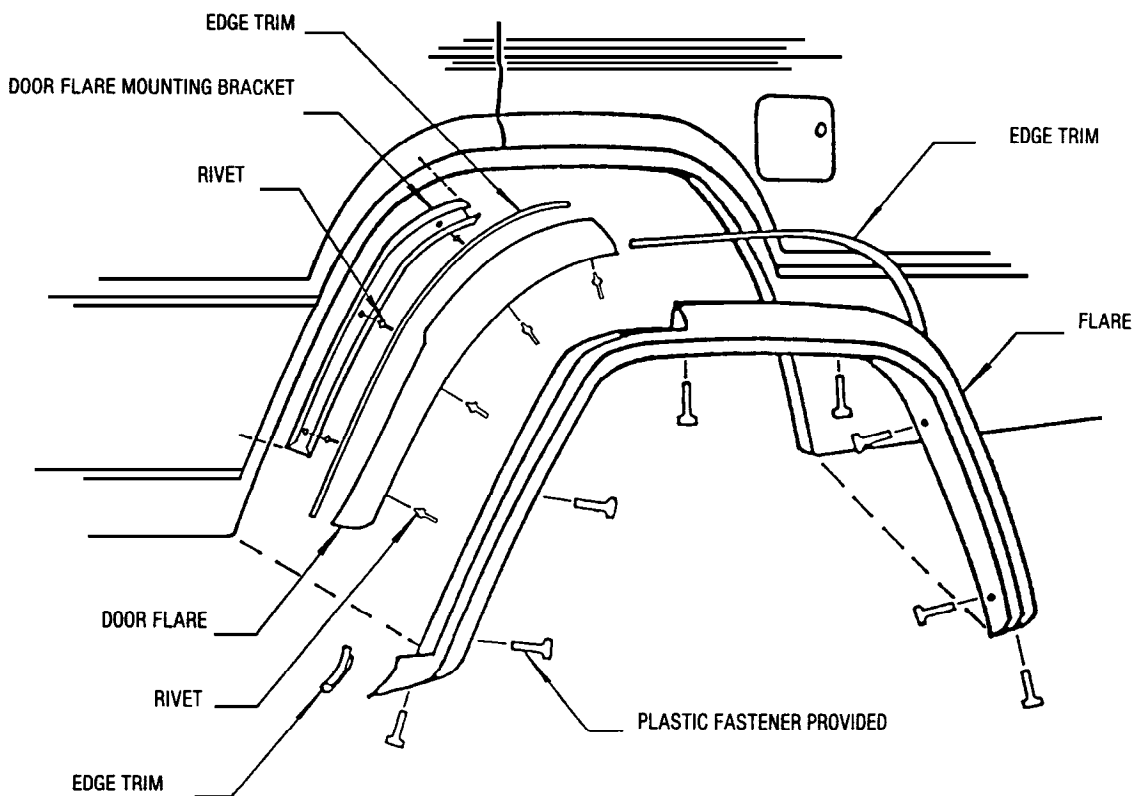
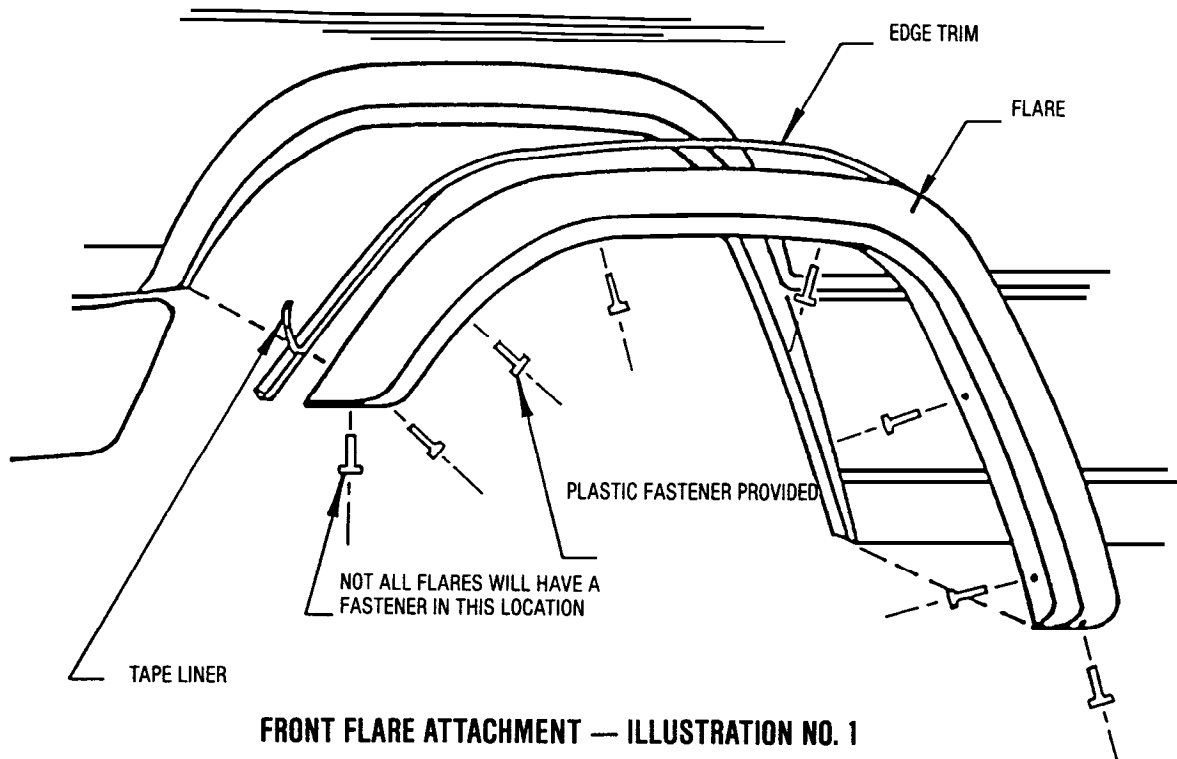

REAR FLARE ATTACHMENT — ILLUSTRATION NO. 2
(31907 DOES NOT HAVE DOOR FLARE AND MOUNTING BRACKET)

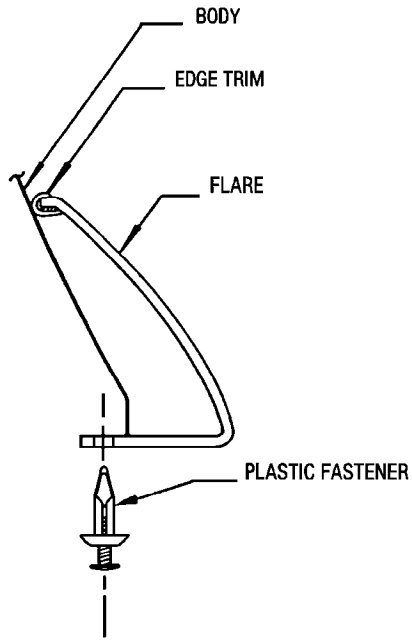

**FRONT AND REAR MAIN BODY ATTACHMENT
ILLUSTRATION NO. 3**

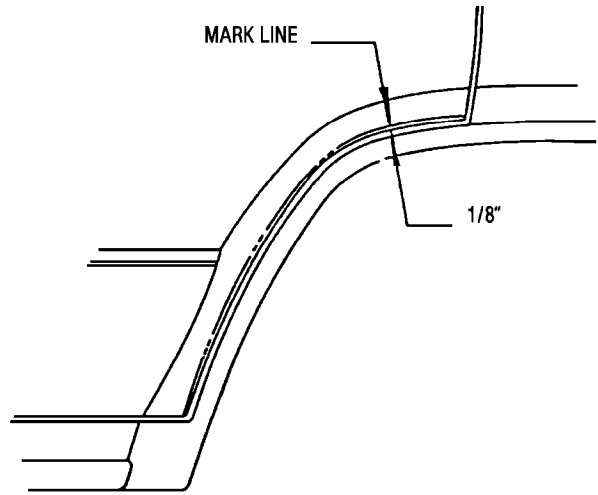

**DOOR FLARE MOUNTING BRACKET LOCATION DIMENSION
ILLUSTRATION NO. 4**

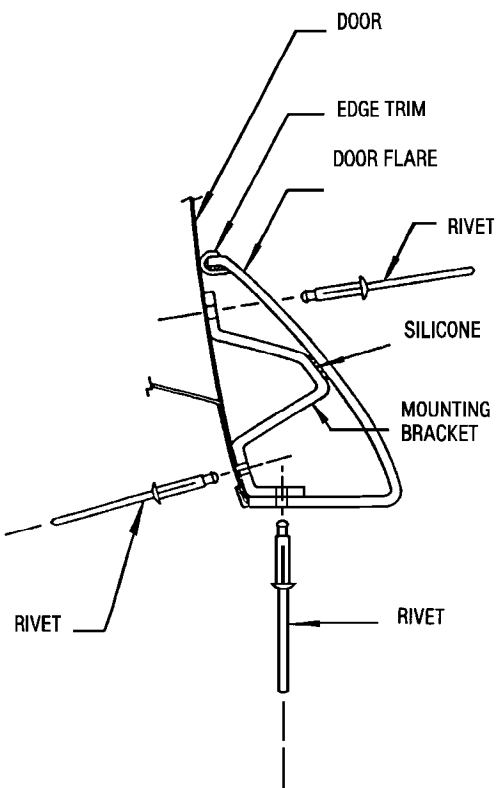

**EXPLORER, S-10 BLAZER AND TROOPER
REAR DOOR FLARE ATTACHMENT — ILLUSTRATION NO. 5**

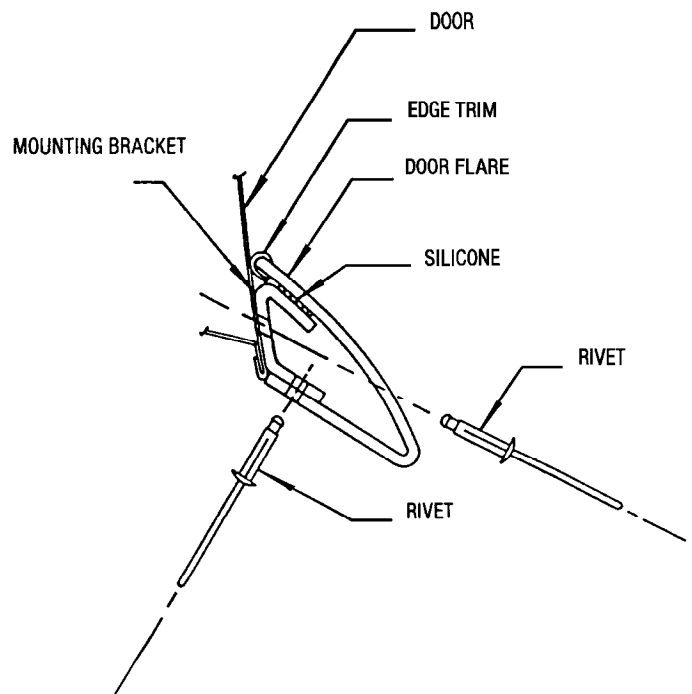

**PATHFINDER AND RODEO
REAR DOOR FLARE ATTACHMENT — ILLUSTRATION NO. 6**