



INSTALLATION INSTRUCTIONS FOR
**40012 CHEVY SPORTSIDE
EXTEND-A-FENDER**

TOOLS REQUIRED FOR INSTALLATION:

- Electric Drill
- #2 Phillips driver bit
- 3/16" Drill Bit
- 3/8" Drill Bit
- Utility Knife
- Grease Pencil

IMPORTANT: READ BEFORE BEGINNING INSTALLATION

Verifying Fit – Flares should be held to the vehicle surface to verify correct type and fit BEFORE beginning installation. Small fit adjustments can be made by trimming (filing, sanding or scraping) the excess plastic.

Exhaust System – Modifications may be necessary to maintain a minimum 4" clearance between flares and exhaust pipes. Exhaust gases should not vent directly onto flares.

Metal Protection – All exposed fasteners and bare metal should be treated with red oxide primer BEFORE installing flares.

DO NOT USE: Loctite, SuperGlue, or similar products on the hardware or the flares.

FLARE INSTALLATION PROCEDURES

Step 1: Painting

It is recommended that painting (when desired) be done prior to installation.

- (A) Sand (optional) before application of paint.
- (B) Clean outer surface with a good grade degreaser. Do not use lacquer thinner or enamel reducer as a degreaser. Wipe outer surface thoroughly with a tack rag prior to painting.
- (C) Paint flares using a high quality lacquer, enamel, or polyurethane automotive paint. Application of a primer coat is optional. Painting edge trim is not recommended.

Step 2: Step Pad and Accent Molding Modifications

- (A) **Trimming Step Pads for vehicles so equipped**
 1. Place flares in position in wheel well opening and mark where they intersect with step pads.
 2. Remove flare and protect vehicle surface with tape near point of intersection.
 3. Cut pads along marked line. Care should be taken to avoid cutting paint.
- (B) **Modifying Accent Molding in the Wheel Well Area (when required)**
 1. Remove chrome accent moldings.
 2. Bend accent molding to match flare edge contour and reattach using stock fasteners or drill screws (not included).

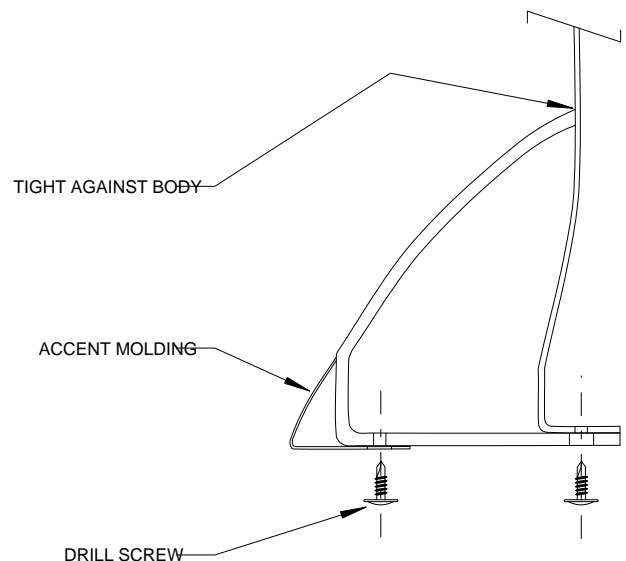

FIGURE 1

Step 3: Trimming Body Side Molding.

On vehicles with body side molding it will be necessary to trim either the flares or moldings. Note: Trimming the molding usually produces better results.

(A) (Option I) Trimming Side Molding

1. Place flare into wheel well opening and mark where molding intersects flare.
2. Remove flare and peel the molding back to a point beyond the marked line using a putty knife.
3. Cut molding on marked line with heavy duty scissors.

(B) (Option II) Trimming Flare:

1. Place flare into wheel well opening and mask flare at point of intersection with the molding.
2. Trace molding contour onto flare at point of intersection.
3. Trim flare along traced contour line. See FIGURE 2.

Step 4: Flare Attachment (Front and Rear)

- (A) Pre-drill all screw indentations in the flare with a 3/16" drill bit. DO NOT DRILL SHEET METAL WITH 3/16" DRILL BIT.
- (B) Remove fender fasteners from lower front and rear of wheel well. Mark and drill flare using 3/8" bit to match fastener locations.
- (C) Attach edge trim to outside lip of flare.
- (D) Fasten the flare to the vehicle with drill screws using the holes in the flare as a guide. Follow the fastening sequence illustrated in FIGURE 2.

Patent No. 4,169,608

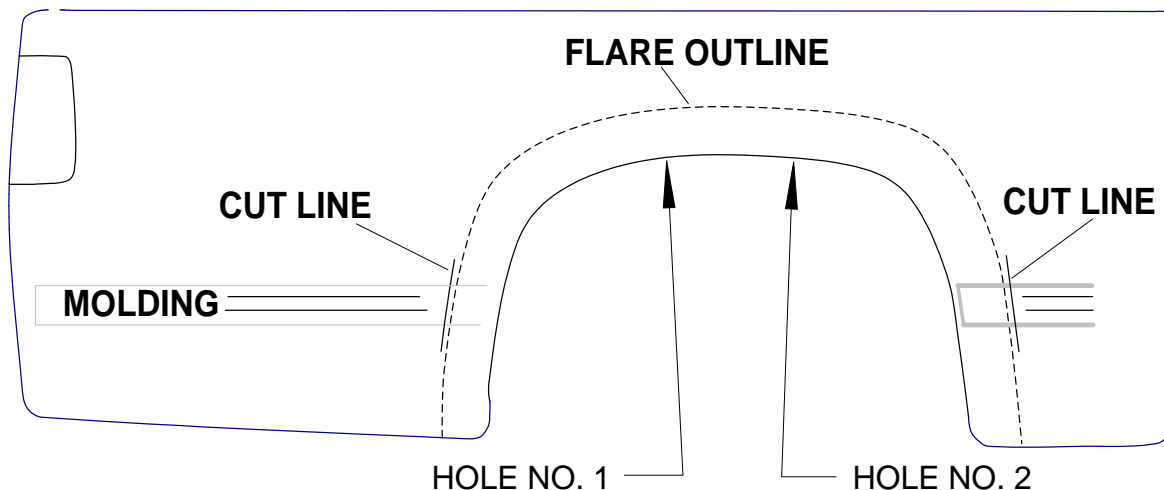

FIGURE 2