



40032  
04-13-09  
REV-2

# INSTALLATION INSTRUCTIONS CHEVROLET SILVERADO – GMC SIERRA

Part Numbers 40031, 40032, 40906  
(Front) (Rear) (Set)

## TOOLS REQUIRED FOR INSTALLATION:

- Jack and Jack Stands (Optional)
- Utility Knife

## IMPORTANT: READ BEFORE BEGINNING INSTALLATION

**Verifying Fit** - Flares should be held to the vehicle surface to verify correct type and fit BEFORE beginning installation or painting. The inner flare edge should be in contact with the wheel well rim, and the outer flare edge should conform to vehicle fender contours. Small fit adjustments can be made by trimming (filing, sanding or scraping) excess plastic.

**Performance** - Using larger tires may increase the area required to turn the vehicle. Some Tire/Rim combinations may require lowering bump stops and/or installing steering stops to prevent tire shoulders from contacting flare.

**Exhaust System** - Modifications may be necessary to maintain a minimum 4" clearance between flares and exhaust pipes. Exhaust gases should not vent directly onto flares.

**DO NOT USE:** Loctite, SuperGlue, or similar products on the hardware or the flares.

## FLARE INSTALLATION PROCEDURES

### Step 1: Painting

It is recommended that painting (when desired) be done prior to installation.

- Sand (optional) before application of paint.
- Clean outer surface with a good grade degreaser. **DO NOT USE LACQUER THINNER OR ENAMEL REDUCER AS A DEGREASER.** Wipe outer surface thoroughly with a tack rag prior to painting.
- Paint flares using a high quality lacquer, enamel, or polyurethane automotive paint. Application of a primer coat is optional.
- If painting edge trim (not recommended) use a flex additive.

### Step 2: Preparing the Work Area (Front and Rear)

- Support and remove wheel using jack and jack stands. (Optional)
- Remove factory fender trim and mud flaps (when installed).

### Step 3: Edge Trim Installation (See Illustration #1)

- Peel two to three inches of red vinyl backing away from edge trim tape. Applying the adhesive side of the edge trim to the inner side of the flare, affix the edge trim to the top edge of the flare (the portion that comes in contact with the side of the vehicle).
- Press edge trim into place along the top edge of the flare in one-foot increments, pulling red vinyl backing free as you continue to work your way around the top edge of the flare.

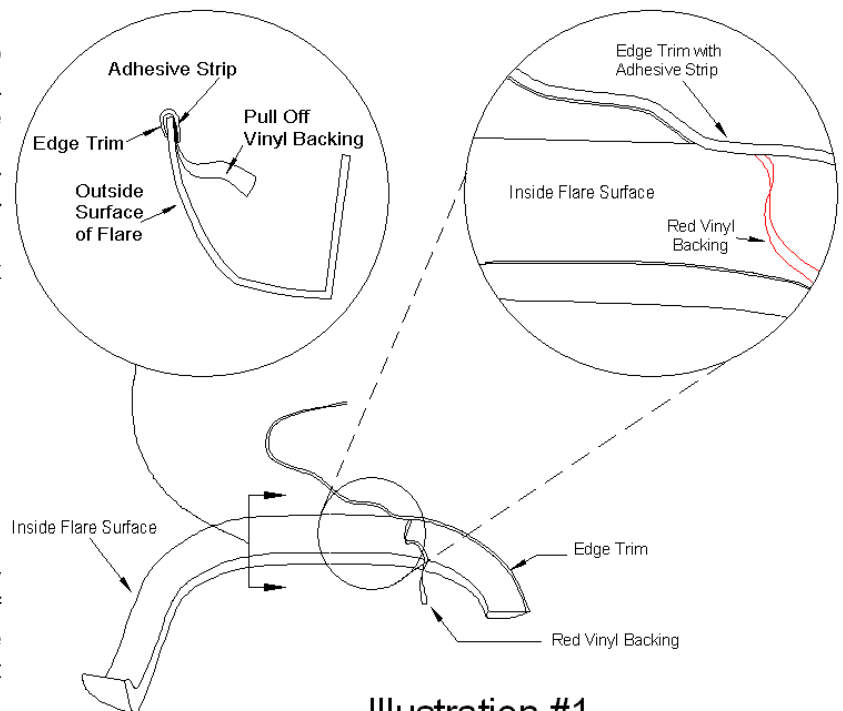

Illustration #1

**Step 4: Flare installation (See Illustration # 2)**

**(A) FRONTS:**

1. Using moderate pressure hold flare in wheel well opening, making sure flare is under wheel well liner.
  2. Starting at top center, insert plastic screw type Tuflok®; snap in hole of flare and wheel well.
- Separating the Tuflok® before inserting will help in installation.

**(B) REARS:**

1. For the top center oversized hole in sheet metal, use the included nylon washer with 1/4" hole to hold flare in place. (See Illustration #3)

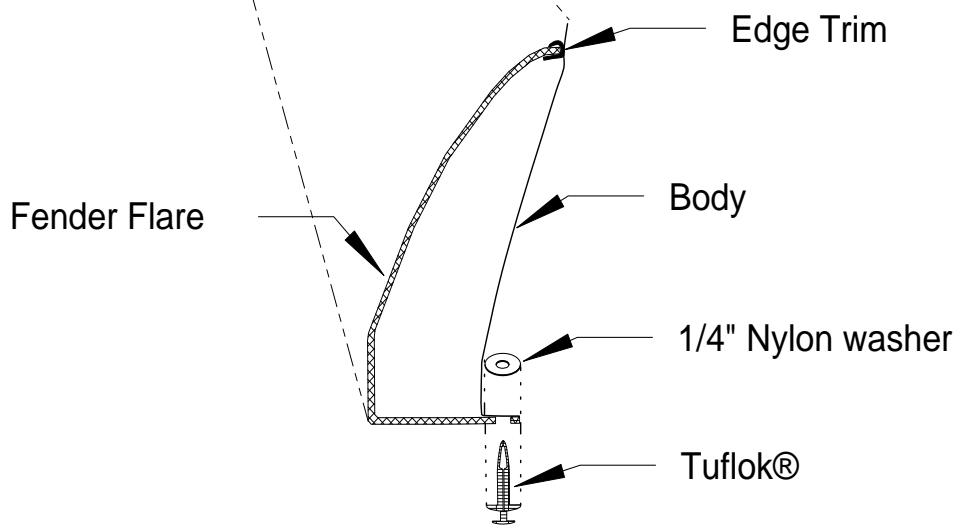
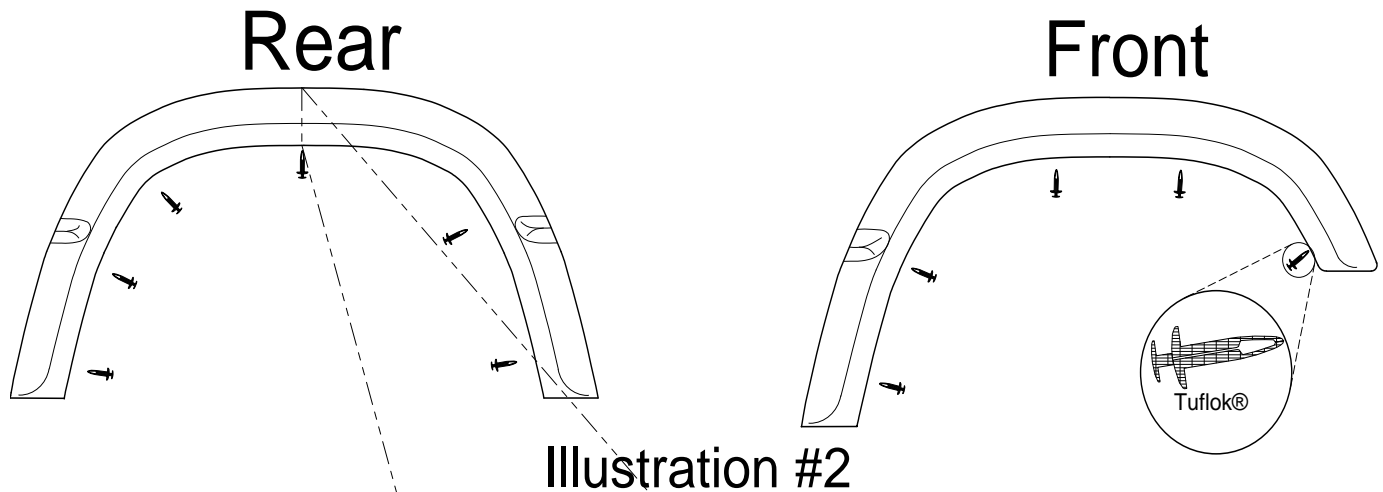

**Illustration #3**  
Cross Section