



INSTALLATION INSTRUCTIONS DODGE RAM EXTEND-A-FENDER STYLE

TOOLS REQUIRED FOR INSTALLATION:

- Jack and Jack Stands (Optional)
- #25 Torx™ Driver Bit
- Utility Knife
- # 2 Phillips Driver bit

IMPORTANT: READ BEFORE BEGINNING INSTALLATION

Verifying Fit - Flares should be held to the vehicle surface to verify correct type and fit BEFORE beginning installation or painting. The inner flare edge should be in contact with the wheel well rim, and the outer flare edge should conform to vehicle fender contours. Small fit adjustments can be made by trimming (filing, sanding or scraping) excess plastic.

Performance - Using larger tires may increase the area required to turn the vehicle. Some Tire/Rim combinations may require lowering bump stops and/or installing steering stops to prevent tire shoulders from contacting flare.

Exhaust System - Modifications may be necessary to maintain a minimum 4" clearance between flares and exhaust pipes. Exhaust gases should not vent directly onto flares.

DO NOT USE: Loctite, SuperGlue, or similar products on the hardware or the flares.

FLARE INSTALLATION PROCEDURES

Step 1: Painting

It is recommended that painting (when desired) be done prior to installation.

- Sand (optional) before application of paint.
- Clean outer surface with a good grade degreaser. **DO NOT USE LACQUER THINNER OR ENAMEL REDUCER AS A DEGREASER.** Wipe outer surface thoroughly with a tack rag prior to painting.
- Paint flares using a high quality lacquer, enamel, or polyurethane automotive paint. Application of a primer coat is optional.
- If painting edge trim (not recommended) use a flex additive.

Step 2: Preparing the Work Area (Front and Rear)

- Support vehicle and remove wheel using jack and jack stands. (Optional)
- Remove factory fender trim and mud flaps (when installed).

Step 3: Edge Trim Installation (See Illustration #1)

- Peel two to three inches of red vinyl backing away from edge trim tape and affix to outer edge of flare at one end.

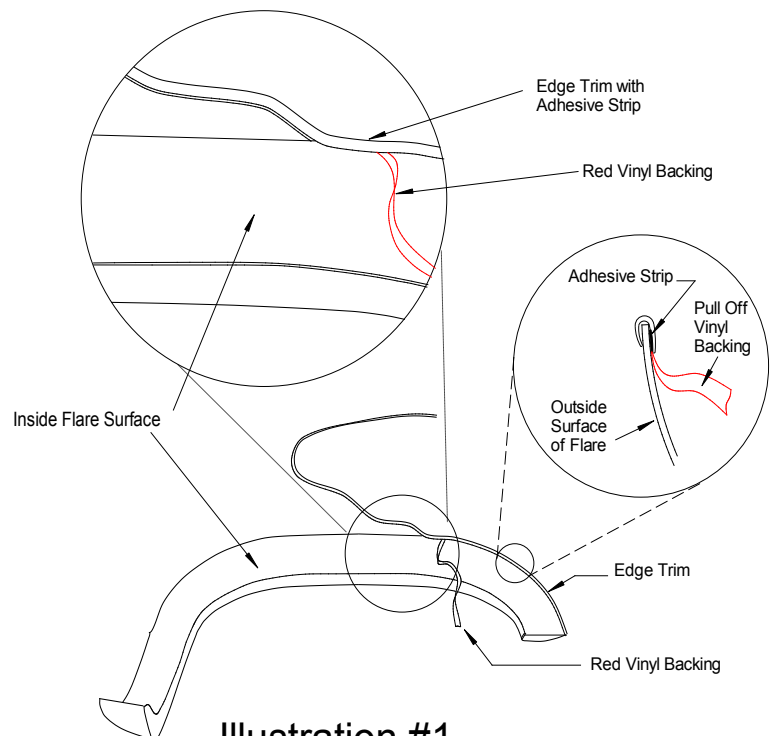

Illustration #1

- (B) Press edge trim into place along edge of flare in one-foot increments, pulling red vinyl backing free as you continue to work your way around the flare.

6710 N. CATLIN AVE. • PORTLAND, OR 97203 • 503-283-4335 • 1-800-234-8920 (USA AND CANADA) • FAX 503-283-3007

Step 4: Front Flare Installation

- (A) Remove the three factory screws from the front wheel well using a # 25 Torx bit. Set aside for further use.
NOTE: Truck with Cummins logo needs to remove before installing flares.
- (B) Holding front flare in place on fender, secure with factory screws through holes drilled in the flare.

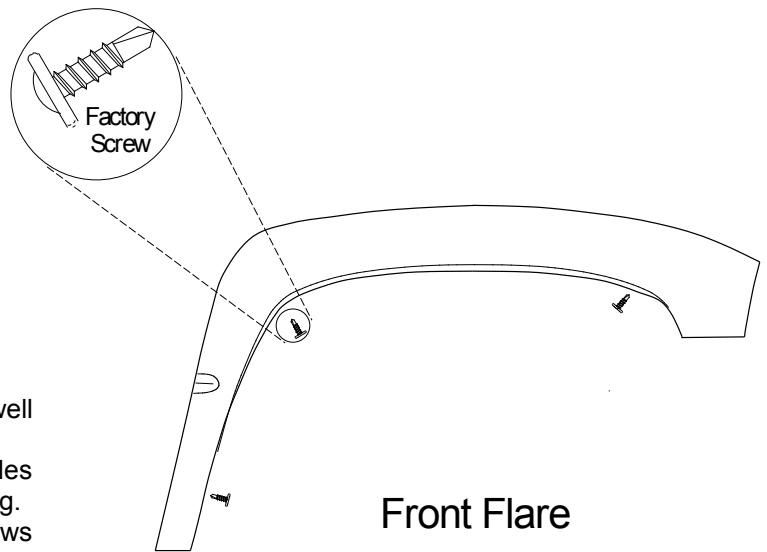

Step 5: Rear Flare Installation

See Illustration: Rear Flare

- (A) Remove the two factory screws from the rear wheel well using a # 25 Torx bit. Set aside for further use.
- (B) Install a clip nut, onto the sheet metal at each of the two holes located in the lower front area of the rear wheel well opening.
- (C) Hold rear flare in place on fender, secure with factory screws through the holes drilled in the flare. Install kit supply screws into clip nut, and secure.
- (D) Refer to illustration rear to install 3 Barbed clips at the top inside the flare.

