

Toyota 2WD & 4WD

T-100

Set Part # 31507

Rev 3 12/08/09

Step 1:

Prior to Installation:

- A) Bushwacker only approves installing the flares according to these written instructions with the hardware provided. **WARNING:** Failure to install according to these instructions will invalidate the warranty. This includes, but is not limited to using alternative installation methods, hardware, or materials. **DO NOT USE:** Loctite, SuperGlue, or similar products on the hardware or the flares.
- B) **Fit:** Verify the fit of the flares to vehicle. **(Some filing, sanding, or cutting may be necessary to ensure proper fit).**
- C) **Painting:** (Optional) if paint is desired it must be done prior to installing flares on the vehicle clean outer surface with a good grade degreaser. **DO NOT USE LACQUER THINNER OR ENAMEL REDUCER AS A DEGREASER.** Wipe outer surface thoroughly with a tack rag prior to paint. Paint flares using a high quality enamel, or polyurethane automotive paint. (Application of a primer coat is optional) If painting edge trim (not recommended), use a flex additive.
- D) **Performance:** Using larger Tires may increase the area required to turn the vehicle. Some Tire/Rim combinations may require lowering bump stops and or installing steering stops to prevent tire from contacting flare.
- E) **Exhaust System:** Modifications may be necessary to maintain a minimum 4" clearance between flares and exhaust pipes. (Exhaust gases should not vent directly onto flares)



TOOLS FOR EASY INSTALLATION

- Jack and Jack Stands
- Metric Hex Wrench Set
- Utility Knife
- Drill and 5/16" Drill Bit

FLARE INSTALLATION PROCEDURES

Step 2: Edge Trim Installation (See Illustration #1)

- A) Remove wheel well molding when necessary.
- B) Pre-fit flare parts to wheel well area and trim if necessary.
- C) Peel two to three inches of red vinyl backing away from edge trim tape. Applying the adhesive side of the edge trim to the inner side of the flare, affix the edge trim to the top edge of the flare (the portion that comes in contact with the vehicle). **See Illustration #1**
- D) Press edge trim into place along the top edge of the flare in one-foot increments, pulling red vinyl backing free as you continue to work your way around the top edge of the flare.

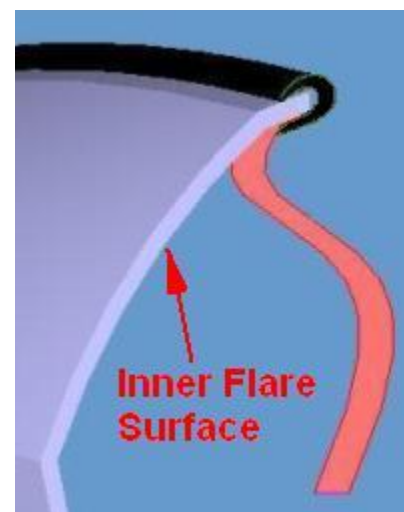

Illustration #1

**Step 3: Attaching Front Flares
(See Illustrations #2 & #3)**

- A) Remove and save screws used to secure liner, factory edge trim, and mud flaps.
- B) Drill seven 5/16" holes along inner flare edge using indents as a guide.
- C) Secure to fender along five forward hole locations using screws removed in Step 3A and one 3/4" screw (provided with kit). **See Illustrations #2 and #3.**
- D) Place mud flap in proper position and mark rear surface "contour lip" where it interferes with flush fit.
- E) Trim "contour lip" on rear surface of mud flap to allow flush fit against surface of flare.
- F) Secure mud flap and lower rear portion of flare using 1" screws removed in Step 3A.

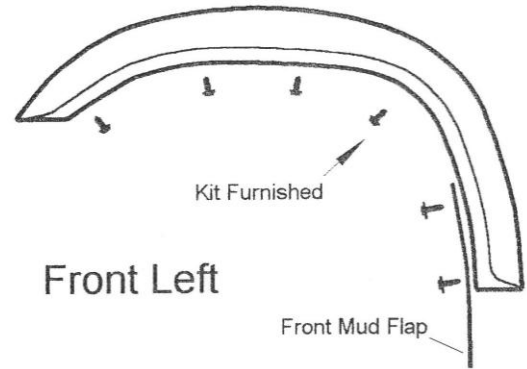

Illustration #2

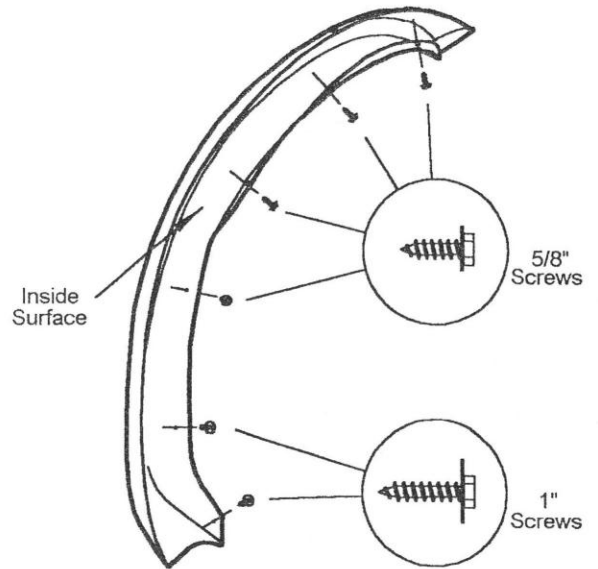

Illustration #3

**Step 4: Attaching Rear Flares
(See Illustrations #4 & #5)**

- A) Remove and save screws securing mud flap. Any other wheel well trim and fasteners can be removed and discarded.
- B) Align five plastic clip nuts with factory hole locations around fender roll-under lip. Clips should be placed with "post" to inside. **See Illustration #4.**
- C) Drill six 5/16" holes along flare inner edge using indents as a guide.
- D) Secure flares to fender using five kit supplied screws. **See Illustration #5.**
- E) Place mud flap in proper position and mark rear surface contour lip where it interferes with flush fit.
- F) Trim contour lip on rear surface of mud flap to allow flush fit against surface of flare.
- G) Secure mud flap and lower rear portion of flare using screws removed in Step 4A.

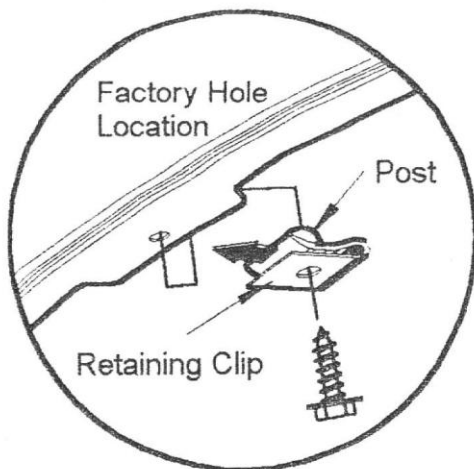

Illustration #4

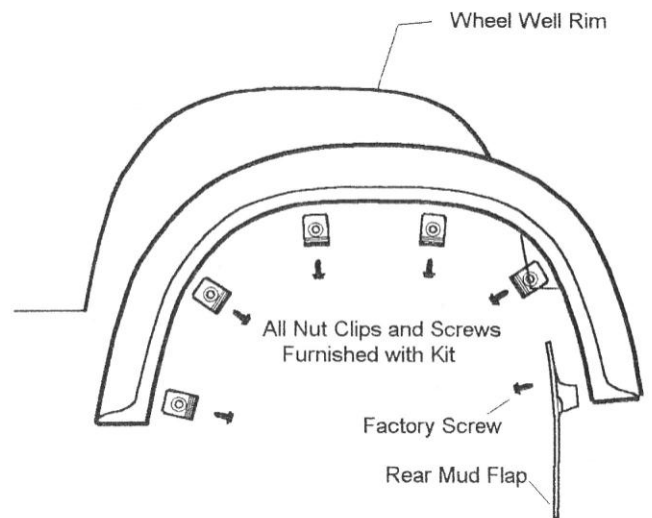

Illustration #5