

REAR VIEW MIRROR INSTALLATION GUIDE FOR WINDSHIELD MOUNT MIRRORS

READ ALL INSTRUCTIONS PRIOR TO START OF INSTALLATION

FEATURES			Wedge Mount Part Number	Camlock Mount Part Number
Prismatic Mirror	Map Lamp		36000	n/a
Auto-dimming			36100	36101
Auto-dimming	Compass		36200	36201
Auto-dimming	Compass	Map Lamps	36300	36301

PARTS LIST

ITEM	COMPONENT	Wedge Mount	Camlock Mount
1	MIRROR ASSEMBLY	1	1
2	POWER WIRE HARNESS	1	1
3	WIRE TAP	1	1
4	WIRE TIE	5	5
5	OPERATION CARD (Models 36200, 36201)	1	1
6	WEDGE BUTTON FOR WINDSHIELD	1	0
7	CAMLOCK MOUNT REPLACEMENT SPRING	0	1

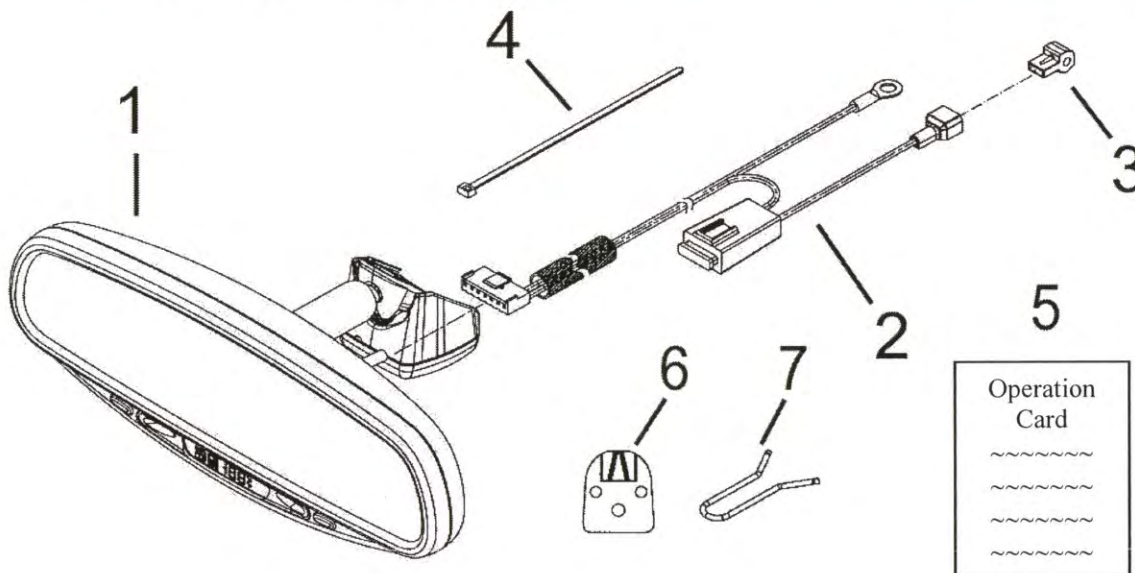

TOOLS REQUIRED	10 mm socket wrench	Multi-meter electrical tester
Clean rag	1/8" (small) flat screwdriver	Pliers
Flashlight	wire cutter	# 20 Torx screw driver (wedge only)

INSTALLATION PRECAUTIONS / NOTES:

- Do not use excessive force when removing OE mirror from windshield. The windshield button may separate from the windshield or the windshield may break.
- Compass Version Only – Do not handle EC mirror by the plastic compass pod below the mirror mount.
- Do not route wiring over sharp metal edges or allow to be pinched behind trim to avoid causing an electrical short or break in the wire.
- Manufacturer not responsible for installation related damage to vehicle.

INSTALLATION PRECAUTIONS / NOTES: (continued)

- Contact original purchase source if additional information is desired regarding these mirror products.
- For installation situations that installer is not familiar with, a qualified installation technician or mechanic should be consulted for assistance.
- Use wire ties to hold wires away from hot engine can critical systems such as brake mechanism.

1.0 VEHICLE PREPARATION

- 1.1 Inspect mirror for damage.
- Place parts on a clean, padded surface.
 - If the vehicle is equipped with an anti-theft radio, the security code must be recorded prior to disconnecting the battery cable. The code should be re-entered after reconnecting the negative battery terminal.
 - Record programmed radio stations.

2.0 REMOVE ORIGINAL EQUIPMENT (OEM) REARVIEW MIRROR

CAUTION: DO NOT USE EXCESSIVE FORCE WHEN REMOVING MIRROR FROM WINDSHIELD. THE WINDSHIELD BUTTON MAY SEPARATE FROM THE WINDSHIELD OR THE WINDSHIELD MAY BREAK.

- 2.1 Wedge mount mirror removal procedure: (Common Method for screwless mount)
Note that there are several versions of mirror mount systems.
If unfamiliar with mirror removal, seek professional assistance.
- Using a small 1/8" (4 mm) flat blade screwdriver, insert the flat end into the opening at the bottom of the mirror mount at the windshield.
 - Slide the screwdriver into the center of the mirror mount until resistance is felt.
 - Gently apply a small amount of additional upward force to lift away locking spring in the mount.
 - While still applying upward pressure with the screwdriver, grasp the mirror bracket and wiggle side to side. Lift mirror up toward the headliner and off the windshield mount button.
- 2.2 Camlock Mirror Removal procedure: (Common Method)
- Grasp the base of the mirror.
 - Rotate 90 degrees left or right.
 - Slide mirror downward toward dash to remove.

3.0 INSTALL NEW INTERIOR MIRROR

- 3.1 Wedge Mount Mirror Installation:
- Holding the mirror assembly by the bracket tube and mirror head, slide the mirror bracket over the mirror button on the windshield.
 - Rock mirror side to side to aid installation until mirror fits tightly onto mirror button.
 - Use #20 Torx screwdriver, to tighten locking screw through hole in bottom of compass Pod below mirror mount.

NOTE: If mirror does not fit mirror button on windshield, purchase Rearview Mirror Adhesive kit from auto supply store and mount wedge style mirror button supplied with kit. Follow adhesive supplier directions for button installation.

- 3.2 Camlock Mount Mirror Installation:
- Remove Retainer spring from Windshield retainer button.
 - Replace with new spring from kit.
 - Hold auto-dimming mirror up to windshield retainer button as if mirror is installed.
 - Rotate the mirror 90 degrees right or left from installed position.
 - Slide the mirror base mount into the retainer button on the windshield moving up from bottom of button.
 - Rotate the mirror back to the final installed position.

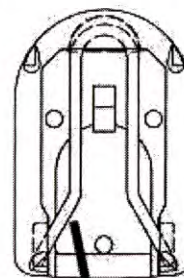

**Mirror Button
Retainer Spring**

4.0 ROUTE THE MIRROR POWER HARNESS AND CONNECT TO MIRROR

- 4.1 Plug the black 7 pin connector into the back of the mirror.
- 4.2 Use fingers or nylon tool to tuck the wire under the front edge of headliner to hide wire. It may be necessary to loosen the sunvisor attachment screws to pull down the front edge of the headliner.
- 4.3 Route the wire along the front edge of the headliner to the driver's side 'A' Pillar and down to fuse area below dash. (See fig 4.1)

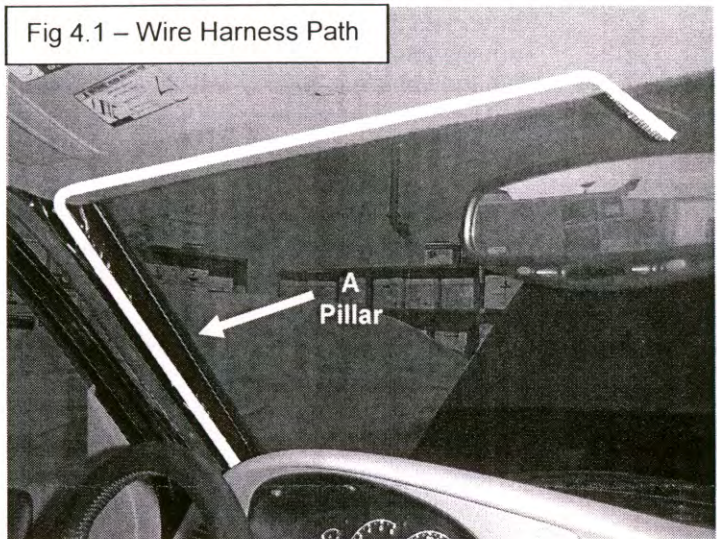

5.0 GROUND WIRE CONNECTION

- 5.1 Locate existing bolt or screw that is in contact with the vehicle's metal body for Ground connection. (See example Fig. 5.1)
- 5.2 Route the mirror ground wire (ring terminal) to the ground bolt.
- 5.3 Remove the bolt or screw from the ground point and install the ring terminal over the ground bolt/screw.
- 5.4 Reinstall and tighten the fastener.

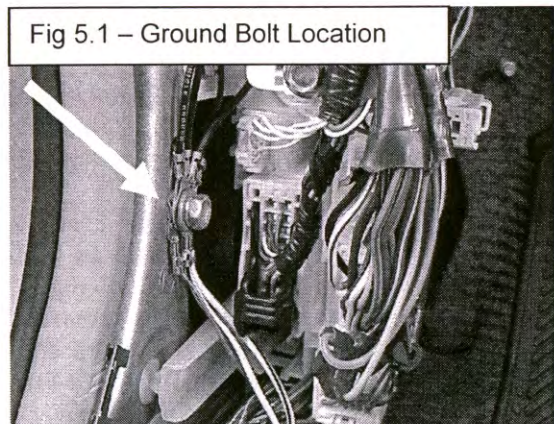

6.0 12-VOLT (POSITIVE) WIRE CONNECTION

- 6.1 Route the 12-volt (spade terminal) wire to an ignition controlled wire.
NOTE: If mirror remains on at all times, it will drain the car's battery.
- 6.2 The power must turn off when the ignition is in the OFF position. Use accessory circuit wire when controlled by ignition.
- 6.3 Disconnect battery ground cable from battery.
- 6.4 Apply T-tap connector to power source wire. (See Fig. 6.1)
- 6.5 Connect the mirror wire to T-tap.
- 6.6 Secure the loose mirror wires with provided cable ties.



7.0 TESTING (Auto-dimming Mirror only)

- 7.1 Reconnect the negative battery cable.
- 7.2 Turn the ignition switch to ON.
- 7.3 With the vehicle in a fairly well lit area, perform the following:
 - Verify that Auto-dimming feature is on. Auto dimming is enabled when green LED is on. Push in left switch to turn auto-dimming ON/OFF. Refer to section 9, "OPERATION", for additional instructions if needed.
 - Cover the forward-looking lightcell located below the wire harness connection on the back of the mirror (a dark cloth or towel will work).
 - After a few seconds, the mirror will begin to darken (the time may vary with ambient light levels).
 - Remove the cover from the forward lightcell and the mirror will begin to clear.
 - The test is now complete.

8.0 FINAL ASSEMBLY

- Reinstall all removed components.
- Re-enter the security code and customer programmed radio stations.
- Place the operation instruction card in the vehicle glove box in the vehicle owner's manual.

9.0 OPERATION

- 9.1 Lighted Mirror - (Part Number 36000)
 - Pressing button under left side of mirror will turn on/off left map lamp.
 - Pressing button under right side of mirror will turn on/off right map lamp.
- 9.2 AUTO-DIMMING MIRROR - (Part Numbers 36100, 36101)
 - Push in center button to turn auto-dimming on/off.
 - Auto-dimming is enabled when Green LED is on.
- 9.3 AUTO-DIMMING MIRROR WITH COMPASS – (Part Numbers 36200, 36201)
 - Press Left button to turn on/off Auto-dimming feature.
 - Auto-dimming is enabled when Green LED is on.
 - Press the Right button to turn Compass display on/off.
- 9.4 AUTO-DIMMING MIRROR WITH COMPASS AND MAP LAMPS – (Part Numbers 36300, 36301)
 - Press left button once to turn on/off left map lamp.
 - Press left button and hold for 4 seconds to turn on/off Auto-dimming feature. Auto-dimming feature is on when Green LED is on.
 - Press left button and hold for 8 seconds times to calibrate compass.
 - Press right button once to turn on/off right map lamp.
 - Press right button for 4 seconds to turn compass display on/off.
 - Press right button and hold for 8 seconds to set the compass zone.

10.0 COMPASS OPERATION – (Part Numbers 36200, 36201, 36300, 36301)

- 10.1 Compass Zone Adjustment - **NOTE:** The zone setting is factory preset to Zone 8. Refer to Compass Calibration Zone Map (See Fig. 10.1) to verify the correct compass zone setting for your geographical location.
- 10.2 To change the zone setting,
 - Push and hold the right button until "ZONE" appears in the display.
 - Push same button repeatedly until the desired compass zone number is shown. The display will change back to the compass direction after three seconds if the button is not activated.

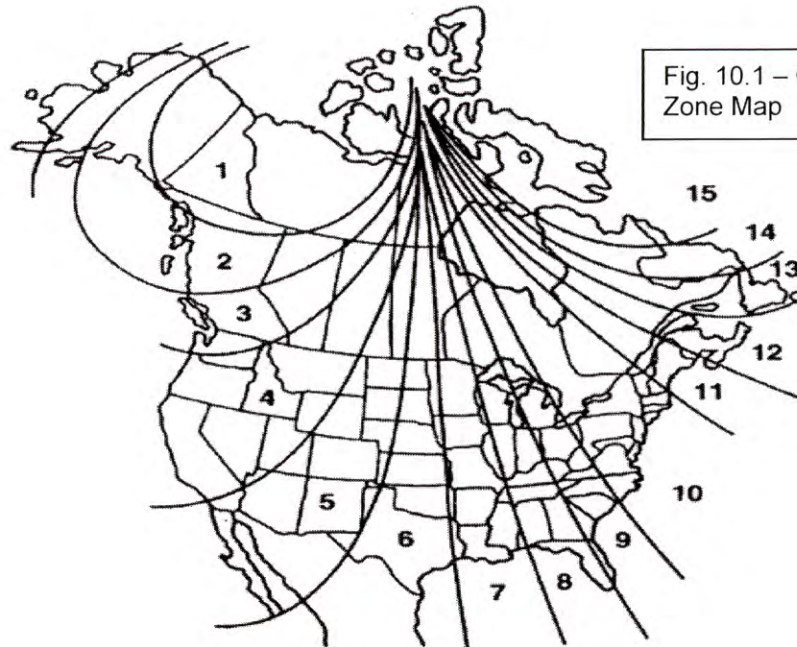

Fig. 10.1 – Compass Calibration Zone Map

- 10.3 Calibration Adjustment -- NOTE: The compass function calibrates itself under normal driving and turning conditions. There is not a need to manually calibrate the compass. If calibration is desired, follow these instructions:
- For optimum calibration, switch off all nonessential electrical accessories (rear window defrost, heater/air conditioning, map lamps, wipers, etc.) and ensure all doors are shut.
 - Drive to an open, level area away from large metallic objects or structures.
 - Push the button to the left of the display until "CAL" icon appears in the display. Release the switch to enter the calibration mode.
 - Drive slowly in a circle until the "CAL" icon disappears in the display (about two or three circles). The compass is now calibrated

Auto-dimming Mirror Trouble Shooting Guide

CONDITION	POSSIBLE CAUSE	ACTION
Mirror face does not dim.	<ul style="list-style-type: none"> • EC function is not on. • Mirror is not receiving power. • Light sensor is blocked. 	Use pinpoint test A.
Mirror face is always dim.	<ul style="list-style-type: none"> • Light sensor is blocked. 	Use pinpoint test B.
Compass display is inaccurate.	<ul style="list-style-type: none"> • Compass pod is not mounted properly. • External magnetic influence is present. • Zone setting is incorrect. • Compass pod was not calibrated. 	Use pinpoint test C.
There is no compass display.	<ul style="list-style-type: none"> • Compass display is switched off. • Mirror is not receiving power. • Compass pod is not connected. 	Use pinpoint test D.
Some segments of display do not work.	<ul style="list-style-type: none"> • Damaged mirror head. 	Use pinpoint test E.
Display does not dim at night.	<ul style="list-style-type: none"> • Damaged mirror head. 	Use pinpoint test F.
Display is always dim.	<ul style="list-style-type: none"> • Light sensor opening blocked. • Damaged mirror head. 	Use pinpoint test G.

NOTE: Mirror will only darken when forward facing (toward windshield) light sensor reads low light (night conditions) and rear facing (toward driver) light sensor is exposed to light source such as head lights through rear window.

PINPOINT TEST A: MIRROR FACE DOES NOT DIM

TEST STEP	RESULT	ACTION
A1: Is green LED on?	YES NO	Go to A2. Push left button. Verify green light. Go to A2. If no green light, go to A3.
A2: With the glass side of the mirror in lighted environment, cover round opening in back of mirror. Verify that rear facing light sensor to right of display is not blocked from light source. Does mirror face dim?	YES NO	Test finished. Mirror functional. Go to A3.
A3: Remove 7-pin connector from back of mirror. Turn ignition to ON position. Measure voltage across pins 1 & 2 with positive lead on pin 1. Is voltage between 9V and 16V?	YES NO	Go to A1. Go to A4.
A4: Verify the correct power harness connection to vehicle. Refer to installation instructions. Is power harness installed correctly?	YES NO	Replace mirror head. Reinstall harness following instructions. Go to A1.

PINPOINT TEST B: MIRROR FACE IS ALWAYS DIM

TEST	RESULT	ACTION
B1: Is anything blocking the forward facing, (toward windshield) sensor opening? Mirror should be evaluated in daylight conditions.	YES NO	Remove obstruction. Verify that mirror changes to high reflectance, (mirror clears). Replace mirror head.

PINPOINT TEST C: COMPASS DISPLAY IS INACCURATE

TEST	RESULT	ACTION
C1: Is pod snapped onto mount?	YES NO	Go to C2. Snap pod on. Go to C2.
C2: Is external magnetic influence (roof antenna, etc.) close to mirror?	YES NO	Move external magnet to location further from mirror. Go to C3.
C3: Is zone set correctly? See zone setting procedure in owner's manual or glove box drive card.	YES NO	Go to C4. Set zone. Go to C4.
C4: Has compass been calibrated and is still inaccurate?	YES NO	Replace mirror head. Calibrate compass using procedure in owner's manual or glove box drive card.

PINPOINT TEST D: THERE IS NO COMPASS DISPLAY

TEST	RESULT	ACTION
D1: Press right most button. Does display turn on?	YES NO	Test finished. Mirror is functional. Go to D2.
D2: Test per A3. Is voltage between 9V and 16V?	YES NO	Go to D3. Test per A4 then go to D1.
D3: Is the harness from the mirror head connected to the pod?	YES NO	Replace mirror head. Plug in compass connector and verify that display turns on.

PINPOINT TEST E: SOME SEGMENTS OF DISPLAY DO NOT WORK

TEST	RESULT	ACTION
H1: Turn ignition to ON position and watch display. Do all segments light up?	YES NO	Test is finished. Mirror is functional. Replace mirror head.

PINPOINT TEST F: DISPLAY DOES NOT DIM AT NIGHT

TEST	RESULT	ACTION
I1: Cover both forward and rear facing light sensor openings. Does display dim after 10 seconds?	YES NO	Test is finished. Mirror is functional. Replace mirror head.

PINPOINT TEST G: DISPLAY IS ALWAYS DIM

TEST	RESULT	ACTION
J1: Are light sensor openings in front and back of mirror blocked?	YES NO	Remove blockage. Replace mirror head.

ONE YEAR LIMITED WARRANTY

Donnelly Corporation ("Donnelly," or the "company") warrants to the original purchaser (the "owner") that the product manufactured by Donnelly (the "product") will be free of defects in material and workmanship for a period of one year from the date of purchase.

Under this warranty, the company will provide one of the following remedies in the case of defect (the choice of remedy to be solely at the option of the company): (i) the company will furnish an equal product or component in exchange for the defective product; or (ii) the company will repair any defect in the product in material or workmanship. No agent, representative, dealer or employee of the company has the authority to increase or to alter obligations or limitations of this warranty.

All defective products must be returned to the retailer where they were purchased OR returned postage pre-paid, with a copy of the original sales receipt to: Donnelly Corp.; Attn: Consumer Products Returns; 620 East Ellis Road; Norton Shores, MI; 49441. A Return Material Authorization (RMA) Number must be obtained from Donnelly's Customer Care Center (866.416.3470) before any products may be shipped and must be clearly written in large characters on the outside of the package before shipment. If a RMA number is not clearly indicated on the outside of the return package, the company reserves the right to refuse shipment.

This warranty covers normal use and installation in the manner described in the included directions. Donnelly does not warrant and is not responsible for defects or damages resulting from the actions of the owner or any third parties, including, but not limited to, the following:

1. Damage caused by failure to provide a suitable installation or operating environment for the product;
2. Damage occurring during shipment (other than original shipment from the company to the owner);
3. Damage caused by accident or misuse of the product, such as impact with other objects, dropping, falls, spilled liquids or immersion in liquids;
4. Damage caused by improper wiring or other installation error;
5. Damage resulting from a collision or other accident involving the vehicle in which the product has been installed;
6. Damage caused by unauthorized attachments, alterations, or modifications of or to the product;
7. Damage caused by the use of the product for purposes other than those for which it is intended to be used;
8. Damage from improper installation or improper maintenance of the product; and
9. Damage caused by any other abuse, misuse, mishandling or misapplication of the product.
10. In no event shall Donnelly be liable for incidental or consequential damages such as labor or loss of use.

THIS WARRANTY IS GIVEN IN LIEU OF ALL OTHER EXPRESS WARRANTIES, WHETHER ORAL OR WRITTEN. THERE ARE NO WARRANTIES, EXPRESS OR IMPLIED, WHICH EXTEND BEYOND THE WARRANTY DURATION SET FORTH ABOVE. DONNELLY EXPRESSLY DISCLAIMS AND EXCLUDES ANY LIABILITY FOR SPECIAL, CONSEQUENTIAL OR INCIDENTAL DAMAGE ARISING FROM ANY DEFECT IN THE PRODUCT, BREACH OF ANY EXPRESS OR IMPLIED WARRANTY, BREACH OF CONTRACT, NEGLIGENCE OR ANY OTHER LEGAL THEORY. Some states do not allow the exclusion or limitations of incidental or consequential damages, so the above limitation or exclusion may not apply to you. In addition, some states do not allow limitations on how long an implied warranty lasts, so the above limitation may not apply to you. This warranty gives specific legal rights to you and may also have other rights which may vary from state to state.

011702 Rev B