



IMPORTANT WARRANTY & INSTALLATION INSTRUCTIONS ATTACHED

*Please Forward All Attached Information to Consumer
Warranty Not Valid Unless Returned to CORSA Exhaust*

We ask that you take a few moments to complete our warranty registration form:

TO ACTIVATE YOUR LIMITED LIFETIME WARRANTY GO TO:

CORSAPERFORMANCE.COM/WARRANTY



For Full-Color Installation Instructions, Please Visit:

CORSAPERFORMANCE.COM and Search by Part Number

Please be sure to review the enclosed instructions prior to beginning the installation process. If you have any questions about the enclosed parts, instructions or encounter a problem during Installation: **CALL CORSA PERFORMANCE TECHNICAL ASSISTANCE AT 800.486.0999**

Please take time to read and understand these installation instructions.

CORSA recommends that installation of this system be performed by an authorized CORSA service center or professional muffler installer who has the necessary equipment, tools and experienced personnel. However, if you decide to perform this install, the use of a hoist and an additional person will be required.

CAUTION: Never work on a hot exhaust system. Allow time for the vehicle to cool. Always wear eye protection when working under a vehicle.

Please confirm that all parts are present before beginning the factory exhaust system removal and CORSA exhaust system installation.

Bill of Materials:

- Driver Side Rear Muffler Assembly (17CH2041)
- Passenger Side Rear Muffler Assembly (17CH2042)
- Driver Side Axle Pipe (17CH4070)
- Passenger Side Axle Pipe (17CH4008)
- X-Pipe Assembly (17CH2040)
- (6) 2.75" Clamps
- (1) Anti-seize Lube Pouch

Recommended Tools:

- Safety Glasses
- 13mm Wrench
- 13mm Socket
- 15mm Wrench
- 15mm Socket
- Grommet Pullers
- 3/8" Ratchet
- 12" Ratchet Extension
- Torque Wrench

17CH2041
Driver Side Rear
Muffler Assembly

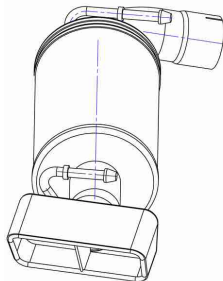

(6) 2.75"
Clamps



(1) Anti-Seize
Lube Pouch



17CH4070
Driver Side
Axle Pipe

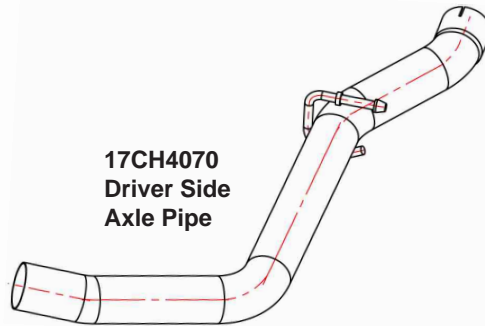

17CH2040
X-Pipe Assembly

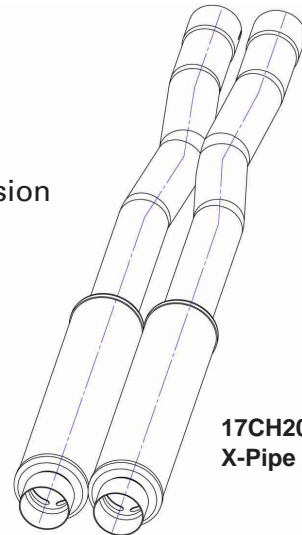

17CH4008
Passenger Side
Axle Pipe



17CH2042
Passenger Side Rear
Muffler Assembly

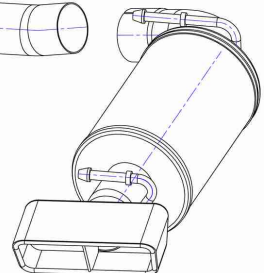



IMPORTANT WARRANTY & INSTALLATION INSTRUCTIONS ATTACHED

*Please Forward All Attached Information to Consumer. Warranty
Not Valid Unless Returned to CORSA Exhaust*

We ask that you take a few moments to
Complete our warranty registration form.

To Activate Your 10 Year LIMITED WARRANTY, Go To:
CORSAPERFORMANCE.COM/WARRANTY



MADE IN THE USA



For Full-Color Installation Instructions, Please Visit:
CORSAPERFORMANCE.COM & Search Part #

Please be sure to review the enclosed instructions prior to beginning the installation process. If you have any questions about the enclosed parts, instructions or encounter a problem during installation, **CALL CORSA PERFORMANCE TECHNICAL ASSISTANCE AT 800.486.0999**

Factory Exhaust System Removal:

NOTE: Penetrating spray lubricant will assist with removal.

1. Loosen the nuts and bolts at the flange connection on the driver side of the tunnel muffler using a 13mm wrench or socket. **(See Fig. A)**
2. Remove the Driver Side factory hangers from the chassis using a 13mm socket and 12" extension attached to a 3/8" ratchet. **(See Fig's B&C)**
3. Remove the driver side axle pipe hanger from the grommet shown in **Fig. D** using grommet pullers or a similar device. Carefully remove the rear driver side section of the stock exhaust from the vehicle.
4. Remove the grommets and chassis hangers from the stock muffler and replace to the original factory position. **Torque the bolts to 18 ft-lbs. (See Fig's E, F&G)**
5. Loosen the crossbar bolts below the x-pipe using a 13mm socket. Remove the crossbar from the chassis. **(See Fig. H)**
6. Remove the grounding clip from the passenger side rear muffler. **(See Fig. I)**
7. Repeat step 2 to remove the Passenger Side factory chassis hangers.
8. Using a 15mm Socket loosen the clamps at the front of the stock exhaust system. **(See Fig. J)**



FIG. A



FIG. B

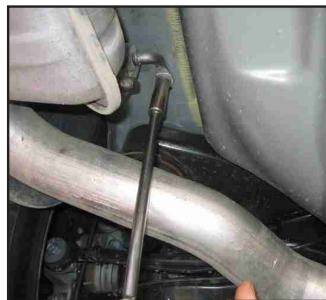

FIG. C



FIG. D



FIG. E



FIG. F

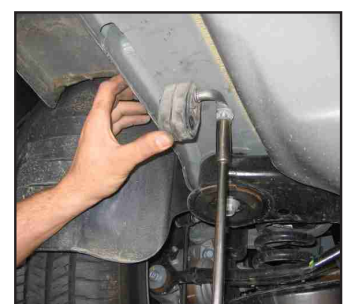

FIG. G



FIG. H



FIG. I

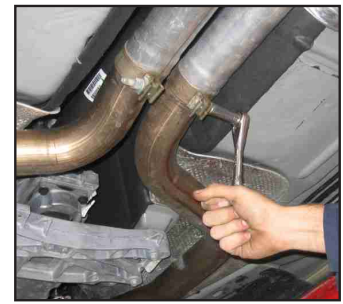

FIG. J

- Remove the passenger side axle pipe hanger from the rubber grommet shown in **Fig. K**. Carefully remove the remaining stock exhaust system from the vehicle. (See **Fig. L**)
- Repeat step 4 for the passenger side. **Fig's M&N** show the passenger side chassis hangers and grommets replaced to the original factory position. **Torque the bolts to 18 ft-lbs.** The removal of the factory system is complete.



FIG. K



FIG. L

CORSA Exhaust System Installation:

NOTE: Apply the anti-seize lubricant (supplied) to the threads ONLY of all the clamps and flange bolts. Failure to follow this procedure can cause nuts to seize on clamps and potentially destroy threads. After applying anti-seize lubricant, be sure to thoroughly clean hands as lubricant will tarnish stainless steel.

All clamps should be tightened using a properly calibrated Torque Wrench. Using an air impact gun will damage the clamp and reduce its ability to effectively seal the joint. It may also cause the joint to separate thereby causing damage to your exhaust system and your vehicle.

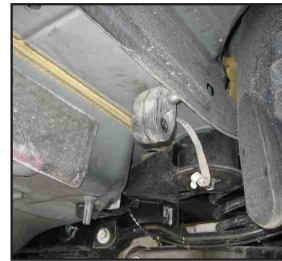

FIG. M

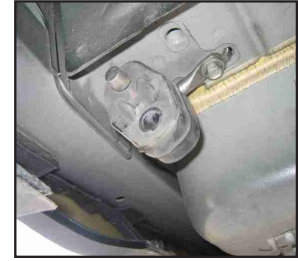

FIG. N

- Locate the CORSA X-pipe assembly. Place two of the supplied 2.75" clamps over the inlet side of the X-pipe. Slide the X-pipe over the stock pipes until the X-pipe completely bottoms out. (See **Fig's O&P**) Pre-tighten the clamps at this time using a 15mm socket or wrench. Leave the clamps loose enough for adjustment later. (See **NOTE to right**) ▶
- Locate the Driver Side Axle pipe and place a supplied 2.75" clamp over the inlet side of the pipe. Then slide the pipe onto the end of the X-pipe assembly and insert the hanger into the factory rubber grommet. (See **Fig's Q&R**) Pre-tighten the clamp at this time. Leave clamp loose enough for adjustment later.
- Repeat step 2 for the Passenger Side Axle pipe. (See **Fig's S&T**)



NOTE: IMPORTANT: Make sure that small drain holes in rear of each tunnel muffler face down when installed.



FIG. O



FIG. P



FIG. Q



FIG. R



FIG. S



FIG. T

4. Locate the Passenger Side Rear muffler and insert a supplied 2.75" clamp over the inlet side of the muffler. Slide muffler onto axle-pipe; then slide hangers into rubber grommets. **(See Fig's U&V)** (Soapy water in the grommet holes will aid in the installation of the muffler.) Insert the grounding clip on the muffler hanger. **(See Fig. W)** Pre-tighten the clamp at this time. Leave clamp loose enough for adjustment later.
5. Locate the Driver Side Rear muffler and insert a supplied 2.75" clamp over the inlet side of the muffler. Slide muffler onto axle-pipe; then slide hangers into rubber grommets as in step 4. **(See Fig's X&Y)** Pre-tighten the clamp. **(See Fig. Z)**
6. Center the tips and adjust clearances to fascia; check all hangers; adjust clearances to underbody.
7. At this time start from the front of the exhaust system and tighten all clamps to **45 ft-lbs.** At each clamp location there will be some axial and rotational adjustment. Make the necessary adjustments to center the exhaust tips with the rear fascia. Then torque the clamps to **45 ft-lbs.**
8. Once tight, verify clearances to underbody components.
9. Replace the factory crossbar at the x-pipe location. Torque the nuts to 18 ft-lbs. **(See Fig. AA)**
10. It is strongly suggested that all clamps be checked and tightened after road testing the vehicle once the system has cooled.



FIG. U



FIG. V



FIG. W



FIG. X



FIG. Y



FIG. Z



FIG. AA

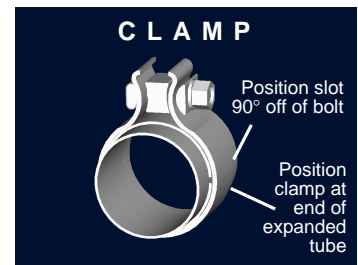

NOTE: During cold weather start-ups, you may experience an exhaust sound that is deeper and louder in tone than usual. This is temporary and will diminish to normal levels once your engine has reached its normal operating temperature. **NOTE:** Immediately following the installation of your exhaust system, you may experience a trace of smoke after initial start-up. **DO NOT** be alarmed. The smoke is caused by the burning of a small amount of forming oil residue used in the manufacturing process.