



11000 INSTALLATION INSTRUCTIONS



Safety glasses should be worn at all times while installing this product.

YEARS: 2006-CURRENT

MAKE: VOLKSWAGEN

MODEL: GOLF, GTI, & RABBIT (INCL. TDI)

STYLE: COMPACT

WARNING: NEVER EXCEED YOUR VEHICLE MANUFACTURER'S RECOMMENDED TOWING CAPACITY





WEIGHT CARRYING:
 TRAILER WEIGHT: 2,000 LBS.
 TONGUE WEIGHT: 200 LBS.

WARNING:
 WE STRONGLY RECOMMEND THE USE OF AUXILIARY STABILIZING STRAPS FOR ALL NON-TRAILER (WHEEL-LESS) LOADS. PLEASE SEE THE CURT CATALOG OR VISIT US ONLINE AT WWW.CURTMFG.COM FOR FURTHER INFORMATION.

INSTALLATION TIME: 15 MIN.

THE INSTALL TIME LISTED IS FOR PROFESSIONAL INSTALLERS. IF YOU ARE HESITANT TO UNDERTAKE THIS TASK ON YOUR OWN, CONTACT AN AUTHORIZED CURT INSTALLER FOR ADDITIONAL ASSISTANCE.

INSTALLATION REQUIRES:

 RATCHET	 TORQUE WRENCH	 9" SOCKET EXTENSION
 18mm 3/4" SOCKET		

INSTALLATION TIPS:

- BEFORE YOU BEGIN INSTALLATION, READ ALL INSTRUCTIONS THOROUGHLY.
- TO EASE INSTALLATION, 2 PEOPLE MAY BE REQUIRED.
- USING PROPER TOOLS WILL GREATLY IMPROVE THE QUALITY OF THE INSTALL AND REDUCE THE TIME REQUIRED.
- NEED HELP OR HAVE SOME QUESTIONS? CALL TECHNICAL SUPPORT AT 800.798.0813

LEVEL OF DIFFICULTY: EASY

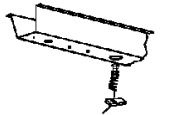
EASY	MODERATE	HARD
	NO DRILLING REQUIRED	
	REVERSE FISHWIRE HARDWARE	

VEHICLE PHOTO:



REPRESENTATIVE PHOTO

HITCH ILLUSTRATION:

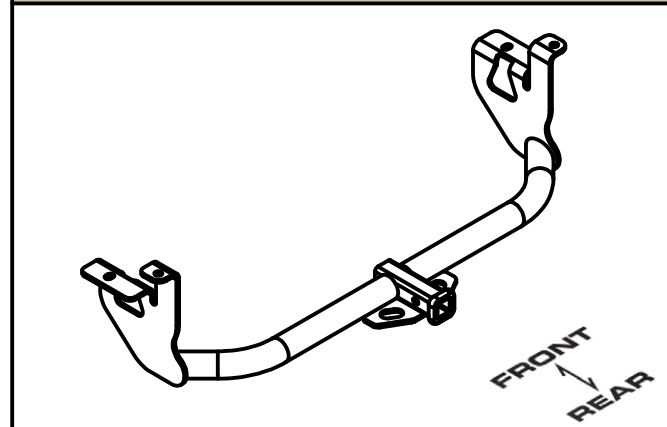

MAKE SURE YOUR HITCH MATCHES

PERIODICALLY CHECK THIS RECEIVER HITCH TO ENSURE ALL FASTENERS ARE TIGHT AND ALL STRUCTURAL COMPONENTS ARE SOUND

CURT Manufacturing Inc. warrants this product to be free of defects in material and/or workmanship at the time of retail purchase by the original purchaser. If the product is found to be defective, Curt Manufacturing Inc. may repair or replace the product at their option, when the product is returned, prepaid, with proof of purchase. Alteration to, misuse of, or improper installation of this product voids the warranty. Curt Manufacturing Inc.'s liability is limited to repair or replacement of products found to be defective, and specifically excludes liability for incidental or consequential loss or damage.

For more information log onto www.curtmfg.com, & for helpful towing tips log onto www.hitchinfo.com

INSTALLATION WALKTHROUGH:

Parts List			
ITEM	QTY	PART NUMBER	DESCRIPTION
1	2	HFN 1213	HEX FLANGE NUT
2	2	1/2 - 13 x 2"	CARRIAGE BOLT
3	2	CM-SP10	.250 x 1.00 x 2.50" SQUARE HOLE SPACER
4	2	1_2 FISHWIRE	1/2" FISHWIRE

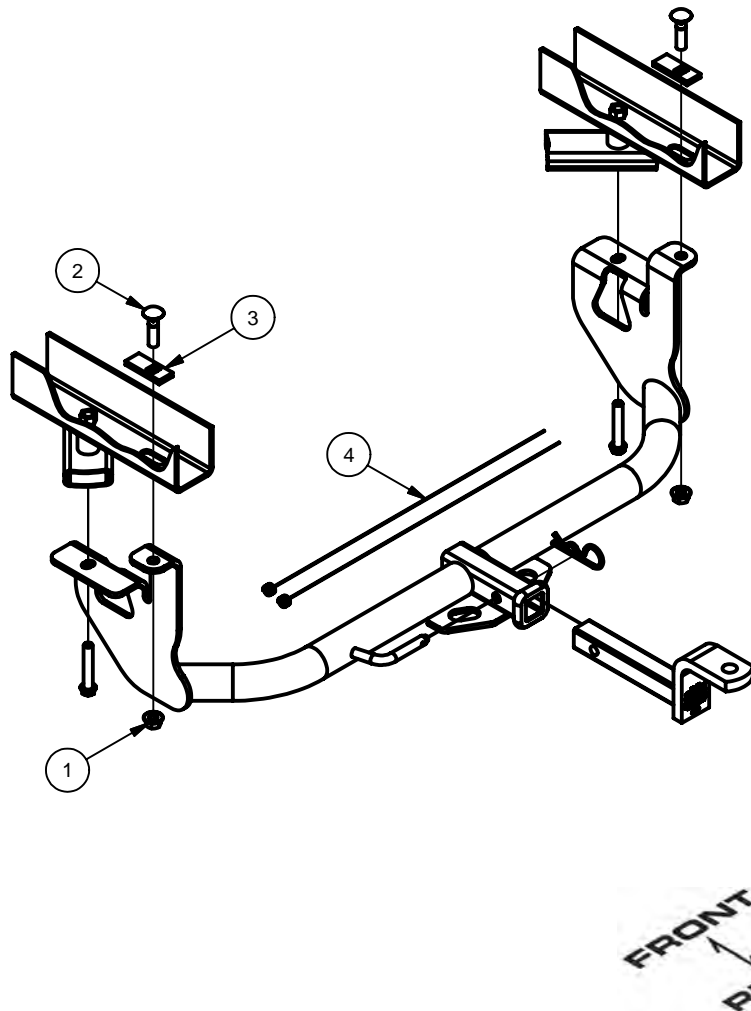

1. Remove existing M12 bolts from driver and passenger side. Retain bolts, they will be used later.



2. Reverse fishwire 1/2-13 x 2" carriage bolts and SP10 spacers through access holes in driver and passenger side frame rails.

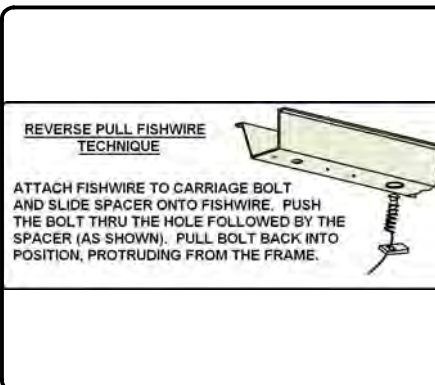

INSTALLATION WALKTHROUGH:

3. Raise hitch into position and secure using M12 bolts removed in Step (1) and 1/2" flange nuts. (**Note:** If necessary to get the passenger side into position, loosen the exhaust hanger on the passenger side to allow the exhaust bracket to move side to side.) Torque all 1/2" hardware to 75 ft-lbs. Torque all M12 hardware to 92 ft-lbs.

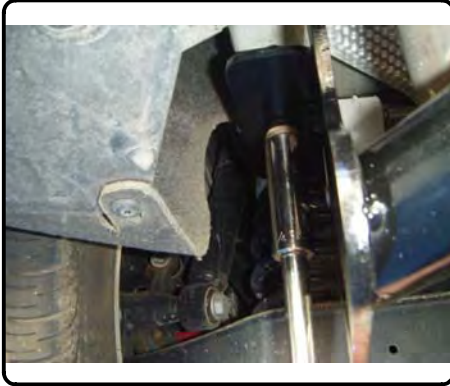

4. Hitch shown installed properly. (Re-tightened the exhaust hanger on the passenger side if loosened in Step 3.)

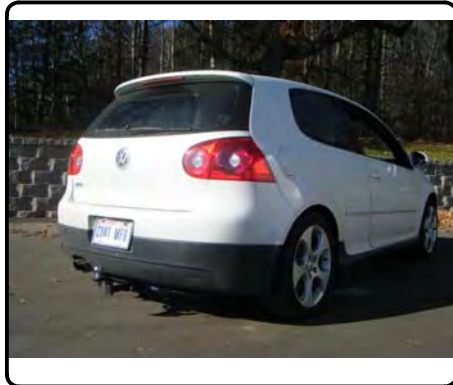

INSTALLATION IS NOW COMPLETE

11000**VOLKSWAGEN RABBIT, GTI, & GOLF****8/18/2010**

INCLUDING TDI

GROSS LOAD CAPACITY WHEN USED AS A WEIGHT CARRYING HITCH: 2,000 LBS. TRAILER WEIGHT & 200 LBS. TONGUE WEIGHT.*****DO NOT EXCEED VEHICLE MANUFACTURER'S RECOMMENDED TOWING CAPACITY.*******WARNING: ALL NON-TRAILER LOADS APPLIED TO THIS PRODUCT MUST BE SUPPORTED BY AUXILIARY STABILIZING STRAPS.****** FAILURE TO PROPERLY SUPPORT NON-TRAILER LOADS WILL VOID PRODUCT WARRANTY******HAVING INSTALLATION QUESTIONS? CALL TECHNICAL SUPPORT AT 1-800-798-0813**

Parts List			
ITEM	QTY	PART NUMBER	DESCRIPTION
1	2	HFN 1213	HEX FLANGE NUT
2	2	1/2 - 13 x 2"	CARRIAGE BOLT
3	2	CM-SP10	.250 x 1.00 x 2.50" SQUARE HOLE SPACER
4	2	1_2 FISHWIRE	1/2" FISHWIRE

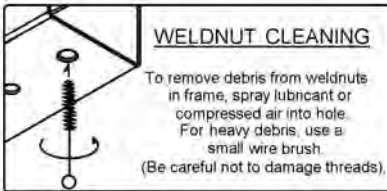
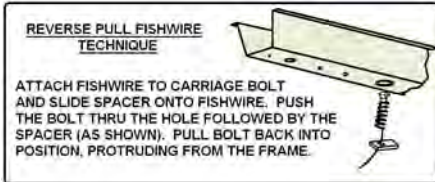

TOOLS REQUIRED
RATCHET
EXTENSION
3/4" SOCKET
18mm SOCKET
TORQUE WRENCH

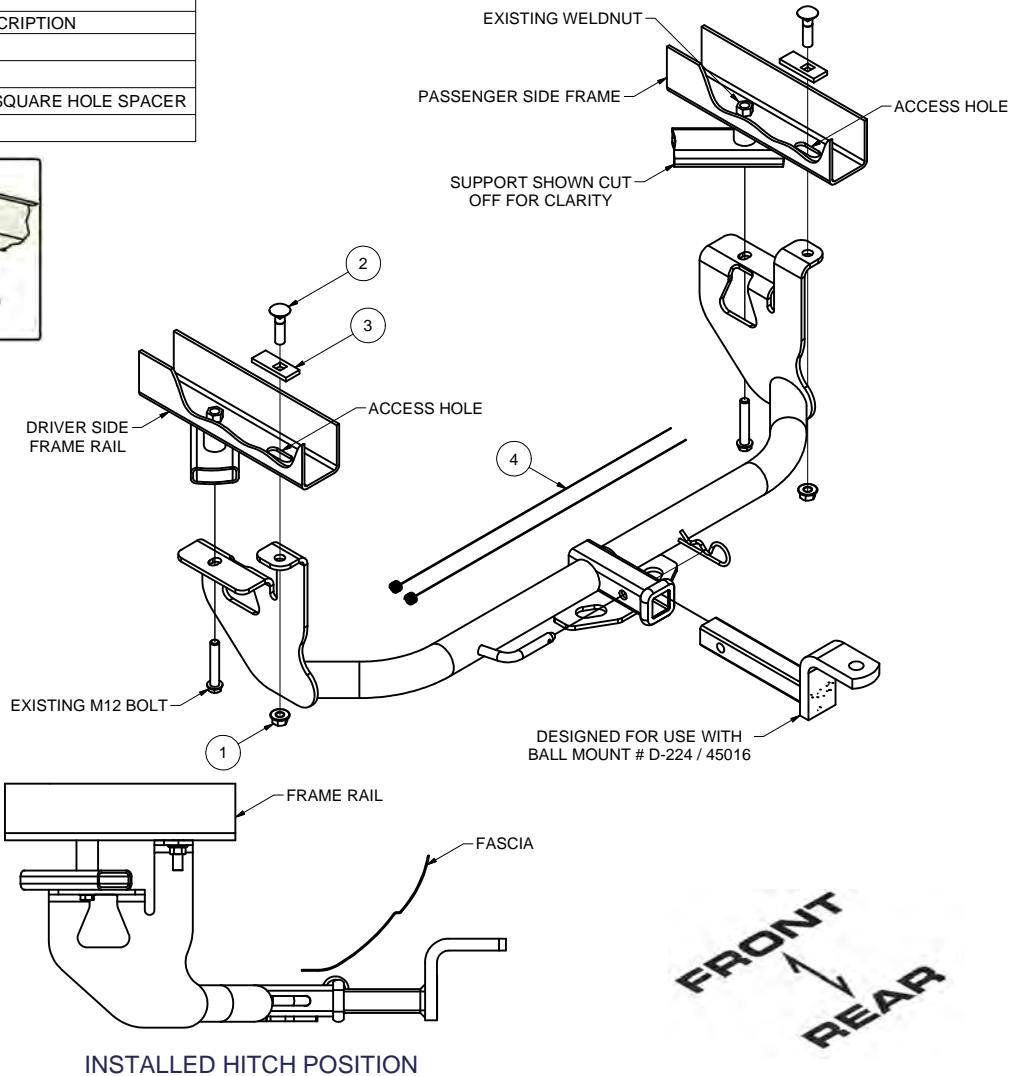
**HITCH WEIGHT: 29 LBS.****INSTALL TIME**PROFESSIONAL: 15 MINUTESNOVICE (DIY): 30 MINUTES**INSTALL NOTES:**

- NO DRILLING REQUIRED
- FISHWIRE HARDWARE

INSTALLATION STEPS

1. Remove existing M12 bolts from driver and passenger side.
2. Reverse pull fishwire 1/2" carriage bolts and SP-10 spacers through access holes in driver and passenger side frame rails. SEE REVERSE FISHWIRE TECHNIQUE
3. Raise hitch into position feeding fishwires through the hitch side plate holes. (Note: If necessary to get the passenger side into position, loosen the exhaust hanger on the passenger side to allow the exhaust bracket to move side to side.)
4. Re-install the M12 bolts through hitch and frame support removed in Step 1.
5. Remove fishwires and install 1/2" flange nuts as shown.
6. Torque all 1/2" hardware to 75 ft-lbs and all M12 bolts to 92 ft-lbs.
7. Re-tighten the exhaust hanger on the passenger side if loosened in Step 3.

PERIODICALLY CHECK THIS RECEIVER HITCH TO ENSURE THAT ALL FASTENERS ARE TIGHT AND THAT ALL STRUCTURAL COMPONENTS ARE SOUND.

Curt Manufacturing Inc., warrants this product to be free of defects in material and/or workmanship at the time of retail purchase by the original purchaser. If the product is found to be defective, Curt Manufacturing Inc., may repair or replace the product, at their option, when the product is returned, prepaid, with proof of purchase. Alteration to, misuse of, or improper installation of this product voids the warranty. Curt Manufacturing Inc.'s liability is limited to repair or replacement of products found to be defective, and specifically excludes liability for incidental or consequential loss or damage.