

11005**SATURN 93-01 SW, 91-02 SL AND 91-02 SC**

9/14/2012

GROSS LOAD CAPACITY WHEN USED AS A WEIGHT CARRYING HITCH: 2,000 LBS. TRAILER WEIGHT & 200 LBS. TONGUE WEIGHT.

*****DO NOT EXCEED VEHICLE MANUFACTURER'S RECOMMENDED TOWING CAPACITY.*******WARNING: ALL NON-TRAILER LOADS APPLIED TO THIS PRODUCT MUST BE SUPPORTED BY AUXILIARY STABILIZING STRAPS.****** FAILURE TO PROPERLY SUPPORT NON-TRAILER LOADS WILL VOID PRODUCT WARRANTY****

HAVING INSTALLATION QUESTIONS? CALL TECHNICAL SUPPORT AT 1-800-798-0813

| Parts List | | | | |
|------------|-----|-------------------|--|--|
| ITEM | QTY | PART NUMBER | DESCRIPTION | |
| 1 | 4 | 7/16 - 14 x 1 3/4 | CARRIAGE BOLT | |
| 2 | 4 | 7/16-14 | HEX FLANGE NUT | |
| 3 | 4 | CM-SP34 | .188 x 1.50 x 3.00" ROUND HOLE SPACER | |
| 4 | 2 | CM-11005-MP | .250 x 1.50 10.25" INSTALLATION SPACER | |

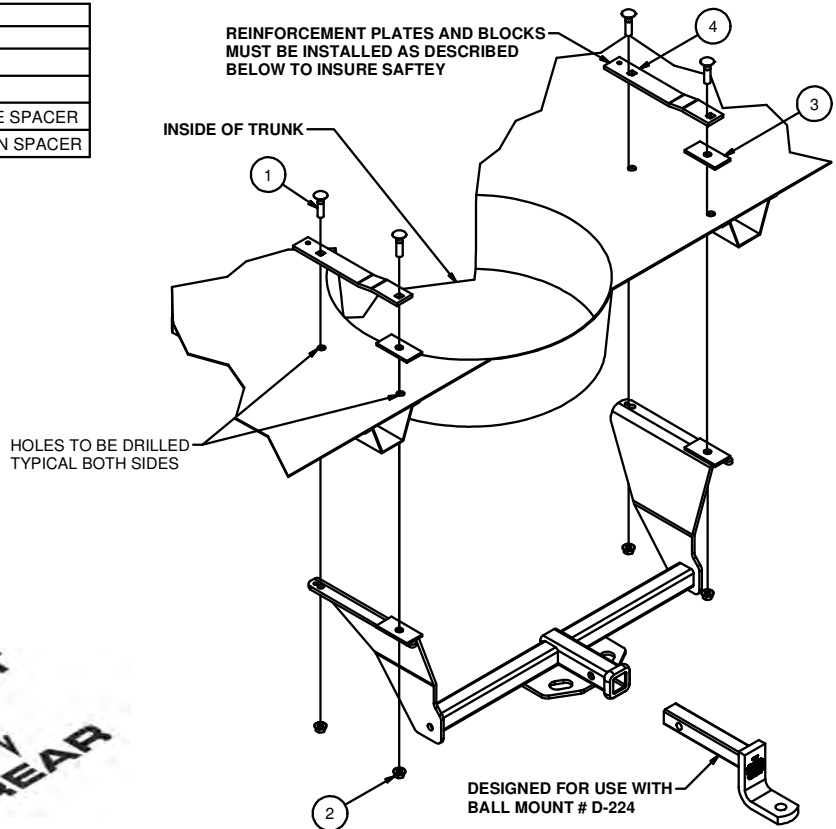
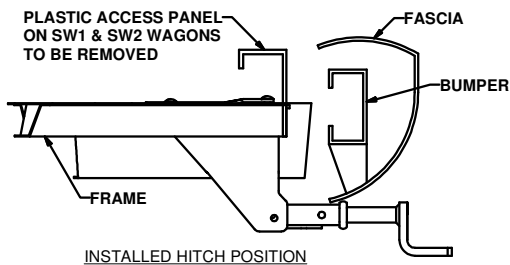

HITCH WEIGHT: 23 LBS.

INSTALL TIME

PROFESSIONAL: 45 MINUTES

NOVICE (DIY): 90 MINUTES

INSTALL NOTES:

DRILLING REQUIRED

INSTALLATION STEPS

- 1) Remove plastic access panel inside trunk forward of vehicle hatch if present. Remove carpet and spare tire cover from inside trunk. Lower muffler by removing 8mm nut from band around muffler. Trim approximately 9" of the exhaust shield up to the inside of the frame rail.
- 2) Position hitch as far rearward as possible on the inside of each frame rail and mark the rearward hole on passenger side for drilling.
- 3) Remove hitch and drill an 1/8" hole up into vehicle as marked then enlarge hole to 9/16".
- 4) Remove all but a thin layer of sealant from inside trunk to allow reinforcement plates and blocks to lay flat in trunk.
- 5) On passenger side position the reinforcement plate and block as shown over the drilled hole. The reinforcement plate and block should line up with the edge of the trunk pan. Mark forward hole on passenger side through reinforcement plate for drilling. Drill a 1/8" hole down into vehicle as marked. Check hole alignment under vehicle and adjust as necessary. Enlarge hole to 9/16". (**Note: Be careful not to drill into muffler below.**)
- 6) Install Reinforcement plate, spacer block and 7/16" carriage bolts as shown. Fasten with 7/16" flange nuts. (**Note: Seal all holes drilled in vehicle to prevent entry of exhaust fumes into trunk.**)
- 7) Using the hitch as a template drill 7/16" holes up into vehicle on drivers side. Install reinforcement plate, spacer block, and 7/16" carriage bolts as shown. Fasten bolts with 7/16" flange nuts. Torque the 7/16" Hardware to 70 lb-ft
- 8) Reconnect muffler and replace spare tire cover inside trunk. Replace plastic access panel if removed in step 1.

PERIODICALLY CHECK THIS RECEIVER HITCH TO ENSURE THAT ALL FASTENERS ARE TIGHT AND THAT ALL STRUCTURAL COMPONENTS ARE SOUND.

Curt Manufacturing Inc., warrants this product to be free of defects in material and/or workmanship at the time of retail purchase by the original purchaser. If the product is found to be defective, Curt Manufacturing Inc., may repair or replace the product, at their option, when the product is returned, prepaid, with proof of purchase. Alteration to, misuse of, or improper installation of this product voids the warranty. Curt Manufacturing Inc.'s liability is limited to repair or replacement of products found to be defective, and specifically excludes liability for incidental or consequential loss or damage.